

# SERVICE MANUAL



## TWIN TYPE



Before using this product, read this SERVICE MANUAL carefully to understand the contents stated herein. After reading this manual, be sure to keep it available nearby the product or somewhere convenient in order to be able to refer to it whenever necessary.

Manufactured in the UK by

**SEGA**<sup>®</sup>



## CONTENTS

1.	BEFORE USING THIS PRODUCT .....	5
1.1.	Inspections Immediately After Transporting The Product To The Location .....	6
2.	INTRODUCTION TO THIS SERVICE MANUAL .....	8
3.	INSTALLATION AND SERVICE INSTRUCTIONS .....	9
3.1.	Handling And Installation Precautions .....	9
3.2.	Coin Handling .....	11
3.3.	Name Of Parts .....	12
3.4.	Accessories .....	13
3.5.	Shipping The Game Board and GD-ROM Drive .....	14
3.5.1.	How To Use The Triforce Carton Box .....	14
3.6.	Shipping The GD-ROM Drive .....	15
3.7.	Assembly Instructions .....	16
3.7.1.	Applying The Play Instructions .....	17
3.7.2.	Assembling The Cockpit .....	18
3.7.3.	Securing In Place (Leg Adjuster Adjustment) .....	19
3.7.4.	Billboard Installation .....	21
3.7.5.	Installing The AC Covers (Wire Covers ) .....	22
3.7.6.	Coin Handling Installation .....	23
3.7.6.1.	Wiring Connections .....	24
3.7.7.	Communication Cables .....	25
3.7.8.	Connection To The Power Supply .....	26
3.7.9.	Assembly Check .....	28
3.7.9.1.	Memory Test .....	28
3.7.9.2.	Input Test .....	29
3.7.9.3.	Sound Test .....	30
3.7.9.4.	CRT Test .....	30
3.7.9.5.	Output Test .....	31
3.7.10.	Moving The Machine .....	32
3.8.	Fuses .....	33
3.9.	Maintenance .....	34
3.9.1.	Removing The Control Panel .....	35
3.9.1.1.	Adjusting/Replacing The Volume .....	36
3.9.1.2.	Greasing .....	38
3.9.2.	Steering Unit .....	39
3.9.2.1.	Adjusting And Replacing The Y-Axis VR .....	40
3.9.2.2.	Replacing The Microswitches .....	46
3.9.2.3.	Greasing .....	49
3.9.3.	Card Reader/Writer Unit .....	50
3.9.3.1.	Setting Dedicated Cards .....	50
3.9.3.2.	Head Cleaning .....	52
3.9.3.3.	Clearing Card Jams .....	53
3.9.4.	Accelerator & Brake .....	54
3.9.4.1.	Removing the Accelerator & Brake .....	54
3.9.4.2.	Adjusting the V.R. .....	55
3.9.4.3.	Replacing the V.R. .....	56
3.9.4.4.	Greasing .....	56
3.10.	Replacement Of Fluorescent Lamp And Other Lamps .....	57
3.10.1.	Fluorescent Lamp Replacement .....	57
3.11.	Cleaning The Cabinet Surfaces .....	58
3.12.	Seat (Greasing To Seat Rail Portion) .....	58
3.13.	Troubleshooting .....	59
3.13.1.	Card Reader/Writer .....	59
3.13.2.	Troubleshooting (When No Error Message Is Shown) .....	62
3.14.	Gameboard .....	65
3.14.1.	Removing The Board .....	65
3.14.2.	Removing The GD-ROM Drive .....	66
3.14.3.	Removing The Game Board (Triforce) .....	68
3.14.4.	Composition Of The Game Board .....	69
3.14.4.1.	DIP SW Setting .....	69
3.14.5.	Replacing The Main Board Battery .....	70
3.14.6.	Replacing The DIMM Board Battery Pack .....	72
3.14.6.1.	Warnings And Restrictions Concerning The Battery Pack .....	72

3.14.7.	Shipping The Game Board And GD-ROM Drive .....	75
3.14.7.1.	How To Use The Triforce Carton Box .....	75
3.14.8.	Machine Set Up .....	76
3.14.8.1.	Network Play .....	77
3.15.	Periodic Check And Inspection.....	82
4.	HOW TO PLAY .....	83
4.1.	Game Description .....	83
4.1.1.	Game Outline.....	84
4.1.2.	Game Mode .....	85
4.1.3.	Playing the Game .....	85
4.1.3.1.	The Card Check Screen .....	85
4.1.3.2.	The F-Zero License Card Screen .....	86
4.1.3.3.	The Name Entry Screen .....	86
4.1.3.4.	The License Card Screen .....	86
4.1.3.5.	The Versus Screen.....	87
4.1.3.6.	The Course Select Screen.....	88
4.1.3.7.	The Machine Select Screen .....	88
4.1.3.8.	The Machine Setting Screen .....	89
4.1.3.9.	Race .....	89
4.1.3.10.	VS Result Screen .....	90
4.1.3.11.	Results Screen (Race Mode), Time Attack Ranking Screen (Time Attack Mode) .....	90
4.1.3.12.	The Pilot Points Screen .....	90
4.1.3.13.	The Configuration Screen .....	91
4.1.3.14.	Memory Card Screen.....	91
4.1.3.15.	The Password Screen.....	92
4.1.3.16.	The Game Over Screen.....	92
4.1.4.	Other Warnings.....	93
4.1.4.1.	Error Display .....	93
4.1.4.2.	Secret Codes .....	93
5.	MAINTENANCE INSTRUCTIONS .....	94
5.1.	Explanation Of Test And Data Display .....	94
5.1.1.	VTS Assembly .....	95
5.2.	System Test Mode.....	96
5.2.1.	RAM Test.....	97
5.2.2.	Media Board Test.....	98
5.2.3.	System Information .....	99
5.2.4.	JVS Test .....	100
5.2.5.	Sound Test.....	101
5.2.6.	C.R.T Test .....	101
5.2.7.	System Assignments.....	102
5.2.7.1.	Coin Assignments .....	102
5.2.7.2.	Coin/Credit Setting (Coin Chute Common Type) .....	103
5.2.7.3.	Coin/Credit Setting (Coin Chute Individual Type) .....	104
5.2.8.	Clock Setting.....	107
5.2.9.	Network Setting.....	108
5.2.10.	Game Test Mode.....	110
5.2.10.1.	Game Test Menu .....	110
5.2.10.2.	Input Test .....	111
5.2.10.3.	Output Test.....	112
5.2.10.4.	Game Assignments.....	114
5.2.10.5.	Network Settings.....	116
5.2.10.6.	Card Test.....	117
5.2.10.7.	Callibration .....	121
5.2.10.8.	Bookkeeping.....	126
5.2.11.	Backup Data Clear.....	128
6.	COIN MECH INSTALLATION AND CREDIT BOARD SET UP .....	129
6.1.	Introduction .....	129
6.1.1.	Price Of Play Settings UK.....	131
6.1.2.	Price Of Play Settings Euro .....	132
6.1.3.	Price Of Play Settings Austria-Czech-Denmark-Norway-Israel-France2 .....	133
7.	DESIGN RELATED PARTS.....	134
8.	PARTS LIST.....	135
8.1.	Assembly Structure.....	135

8.2.	FZR-00001UK TOP ASSY TWIN.....	136
8.3.	FZR-10001UK ASSY COCKPIT 1P .....	138
8.4.	DUT-1120UK ASSY SUB MAIN BASE .....	141
8.5.	FZR-1550 ASSY MONITOR COVER L 2P .....	142
8.6.	APC-1560 ASSY SPEAKER L.....	143
8.7.	FZR-1555UK ASSY MONITOR COVER R 2P.....	144
8.8.	APC-1565 ASSY SPEAKER R .....	145
8.9.	FZR-20001UK ASSY CONTROL PANELSTD.....	146
8.10.	FZR-2500 ASSY STEERING.....	148
8.11.	FZR-2600 ASSY HANDLE MECHA .....	151
8.12.	FZR-2150UK-ASSY START VIEW .....	153
8.13.	FZR-2160UK ASSY MEMORY SLOT .....	154
8.14.	ORT-1100UK ASSY PEDAL BASE ORT.....	155
8.15.	SPG-2200 ASSY BRAKE & ACCELL .....	156
8.16.	FZR-1600UK ASSY SEAT TWIN 1P.....	158
8.17.	FZR-4500UK ASSY MAIN BD.....	160
8.18.	FZR-4600UK ASSY ELEC BD .....	161
8.19.	FZR-1510UK ASSY BASE LID R.....	163
8.20.	FZR-INST-TW ASSY INST KIT FZR TWIN .....	164
8.21.	FZR-0200UK ASSY BILLBOARD.....	165
8.22.	FRI-0300UK ASSY COINCHUTE TOWER FRI .....	167
8.23.	ORT-0500UK ASSY WIRE COVER ORT TWIN.....	168
8.24.	ORT-0400UK ASSY AC BRKT MAIN.....	169
8.25.	ORT-0700UK ASSY AC BRKT SUB .....	170
8.26.	VOF-0450UK CARD UNIT TWIN L.....	171
8.27.	VOF- 0460UK CARD UNIT TWIN R.....	172
9.	APPENDIX A - ELECTRICAL SCHEMATIC.....	173
9.1.	Wire Colours.....	173
9.2.	Electrical Schematic .....	173



# 1. BEFORE USING THIS PRODUCT

To ensure the safe usage, be sure to read the following before using the product. The following instructions are intended for the use of QUALIFIED SERVICE PERSONNEL ONLY.

If any activity is carried out on the product, this should be done only after carefully reading and sufficiently understanding the instructions.

Only qualified service personnel should carry out maintenance on the product.

Depending on the potential risk, terms such as "WARNING!" "CAUTION" and "IMPORTANT!" are used where an explanation is given that requires special attention. SEGA is not responsible for injury or damage caused by use in a manner contrary to the instructions given in this document.

In order to prevent accidents warning stickers and printed instructions are applied in the places where a potentially hazardous situation relating to the product could arise. Be sure to comply with these warnings.



Indicates that mishandling the product by disregarding this warning will cause a potentially hazardous situation that can result in death or serious injury.



Indicates that mishandling the product by disregarding this caution will cause a potentially hazardous situation that can result in personal injury and or material damage.



This is cautionary information that should be complied with when handling the product. Indicates that mishandling the product by disregarding this will cause a potentially hazardous situation that may not result in personal injury but could damage the product.

Be sure to turn off the power and disconnect from the mains supply before working on the machine.

Ensure that the correct fuses are fitted to the machine. Details of these are enclosed in the Service Manual.

Ensure that only qualified Service Engineers perform any maintenance work on the machine.

Specification changes, removal of equipment, conversion and/or additions not designated by SEGA are not permitted and will invalidate this product's CE conformity.

Warning labels or safety covers for personal protection etc, are component parts of the product. A potential hazard will be created if the machine is operated while any parts have been removed. Do not operate the product if any doors, lids or protective covers become damaged or lost. SEGA is not liable in any whatsoever for any injury and/or damage caused by specification changes not designated by SEGA.

Before installing the product, check for the Electrical Specification Sticker, SEGA products have a sticker on which the electrical specifications are detailed. Ensure that the product is compatible with the power supply voltage and frequency requirements of the location in which the machine is to be installed.

Install and operate the machine only in places where appropriate lighting is available, allowing warning stickers to be clearly read.

To ensure maximum safety for customers and operators, stickers and printed instructions describing potentially hazardous situations are applied to potentially hazardous locations. Ensure that the product's operating location has sufficient lighting to allow any warnings to be read. If any sticker or printed warning is removed or defaced, do not operate the machine until an identical item has replaced it.

Exercise great care when handling the monitor (applies only to product with monitor). Some of the monitor (TV) parts are subject to high-tension voltage. Even after turning the power off some components are liable to high-tension voltage. Only qualified service engineers should perform monitor repair and replacement.

In cases where commercially available monitors and printers are used, only the items relating to this product are contained in this manual. Some commercially available equipment will have functions and reactions not referred to in this manual. This manual should be read in conjunction with the specific manufacturer's manual for such equipment.

Descriptions contained herein may be subject to change without prior notification.

The contents described herein are fully prepared with due care. However, should any question arise or errors be found please contact **SEGA AMUSEMENTS EUROPE LTD.**

Descriptions contained herein may be subject to change without prior notification.

The contents described herein are fully prepared with due care. However, should any question arise or errors be found please contact SEGA.

## 1.1. *Inspections Immediately After Transporting The Product To The Location*



- Only QUALIFIED SERVICE PERSONNEL should carry out inspection.

Normally, at the time of shipment, SEGA products are in a state to allowing usage immediately after transporting to the location. Nevertheless, an irregular situation may arise during transportation preventing this. Before turning on the power, check the following points to ensure that the product has been transported safely.

- Are there any dented parts or defects (cuts, etc.) on the external surfaces of the product?
- Are castors and leg adjusters present and undamaged?
- Do the power supply voltage and frequency requirements meet with the local supply?
- Are all wiring connectors correctly and securely connected? Unless connected in the correct direction, connector connections cannot be made successfully. Do not insert connectors forcibly.
- Are all IC's of each IC BD firmly inserted?
- Does the power cord have any cuts or dents?
- Do fuses meet the specified rating?
- Are such units such as monitors, control equipment, IC BD, etc. firmly secured?
- Are all earth wires connected?
- Are all accessories available?
- Can all doors and lids be opened with the accessory keys and/or tools?

**CONCERNING THE STICKER DISPLAY**

SEGA product has stickers describing the product manufacture number (Serial Number) and electrical specification. If you require service assistance you will require the Serial Number. Identical machines may have different parts fitted internally. Only by quoting the Serial Number will the correct parts be identified.

**CONCERNING WARNING STICKERS**

SEGA product has warning displays on stickers, labels or printed instructions adhered/attached to or incorporated in the places where hazardous situations can arise. The warning displays are intended for the accident prevention of customers and service personnel.

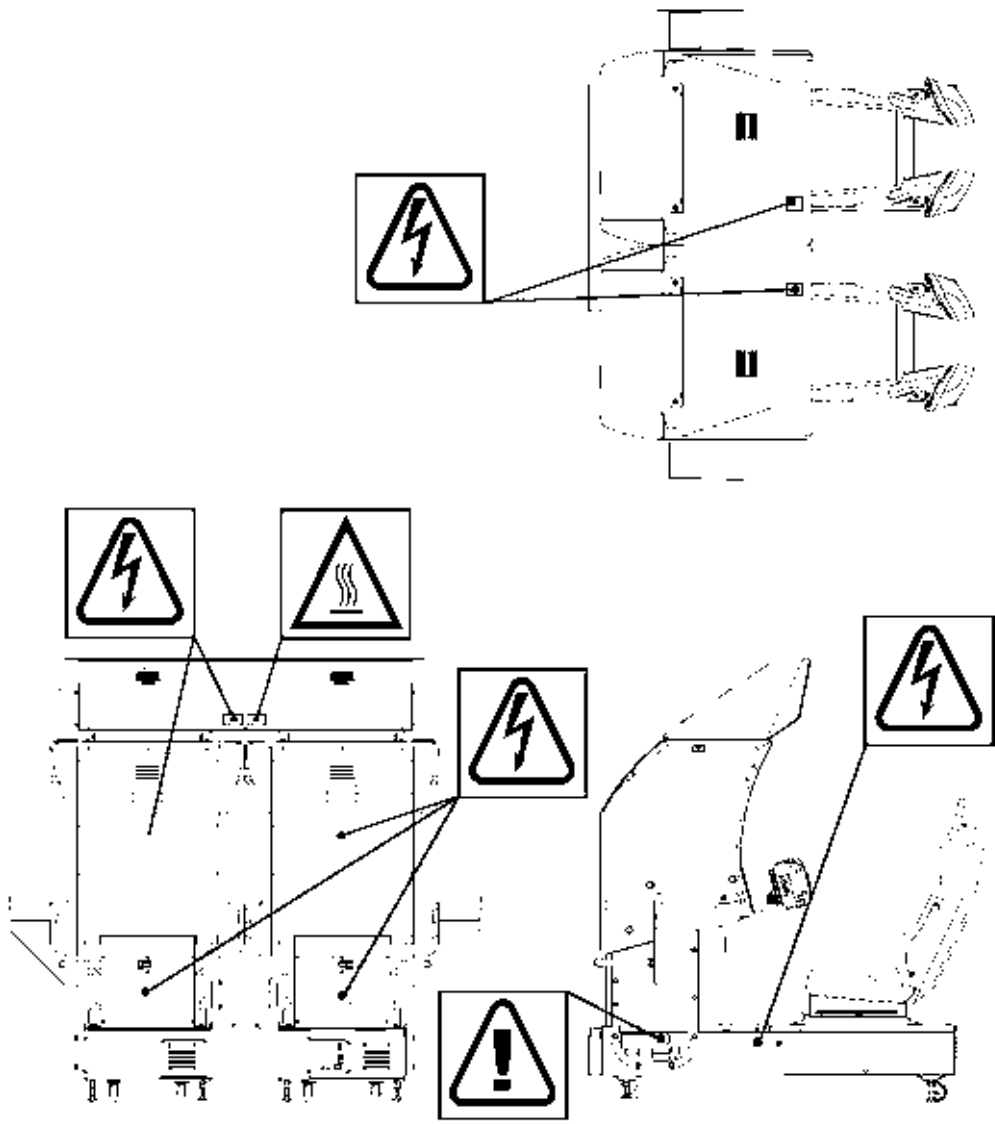

**SPECIFICATIONS**

Installation Space (cm): 202 x 170  
 Height (cm): 187  
 Weight (kg): 492

Power consumption (max):	Rated Voltage (V.AC):	TBA (See Rating Plate on Base Box)
	Rated Current (A):	TBA (See Rating Plate on Base Box)

Note: Descriptions in this manual are subject to change without prior notice.

## **2. INTRODUCTION TO THIS SERVICE MANUAL**

SEGA ENTERPRISES LTD. supported by its experience in electronic high technology of VLSI's, microprocessors etc. and with a wealth of experience, has for more than 30 years been supplying various innovative and popular games to the world market. This Service Manual is intended to provide detailed descriptions together with all the necessary information covering the general operation of electronic assemblies, electro-mechanicals, servicing controls, spare parts, etc. as regards this new SEGA product. This manual is intended for those who have knowledge of electricity and technical expertise especially in IC's, CRT's, microprocessors etc. Carefully read this manual to acquire sufficient knowledge before working on the machine. Should there be any malfunction, non-technical personnel should under no circumstances touch the internal systems. Should such a situation arise contact our head office.

### **SEGA AMUSEMENTS EUROPE LTD./ SEGA SERVICE CENTRE**

Suite 3a  
Oaks House  
12 - 22 West Street  
Epsom  
Surrey  
United Kingdom  
KT18 7RG

### 3. INSTALLATION AND SERVICE INSTRUCTIONS



- Only QUALIFIED SERVICE PERSONNEL should carry out installation and commissioning.

#### 3.1. Handling And Installation Precautions

When installing or inspecting the machine, be very careful of the following points and pay attention to ensure that the player can enjoy the game safely.

**The game must NOT be installed under the following conditions:**

- Outside, the game is designed for indoor use only.
- In areas directly exposed to sunlight, high humidity, dust, excessive heat, or extreme cold.
- In locations that would present an obstacle in the case of an emergency i.e. near fire equipment or emergency exits.
- On unstable surfaces or surfaces subject to vibration.
- Where liquids, other than routine cleaning, may come into contact with the game.

**Important:**

- Only Qualified Service Personnel should install this machine.
- Be sure to switch the supply power OFF and remove the mains supply plug from the machine before any work is carried out on the machine.
- Do not attempt to repair the PCB's (Printed Circuit Boards) yourself. This will void the warranty. The PCB's contain static sensitive devices that could be damaged.
- Always return a faulty part to your distributor with adequate packaging and protection.
- When removing the plug from the mains always grasp the plug not the cable.
- Do not use a fuse that does not meet the specified rating.
- Make sure all connections are secure before applying power.

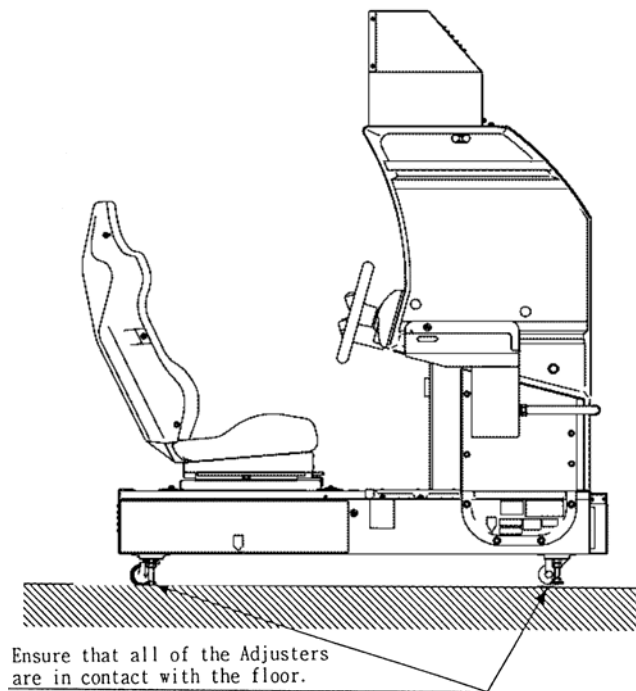

# Installation Space

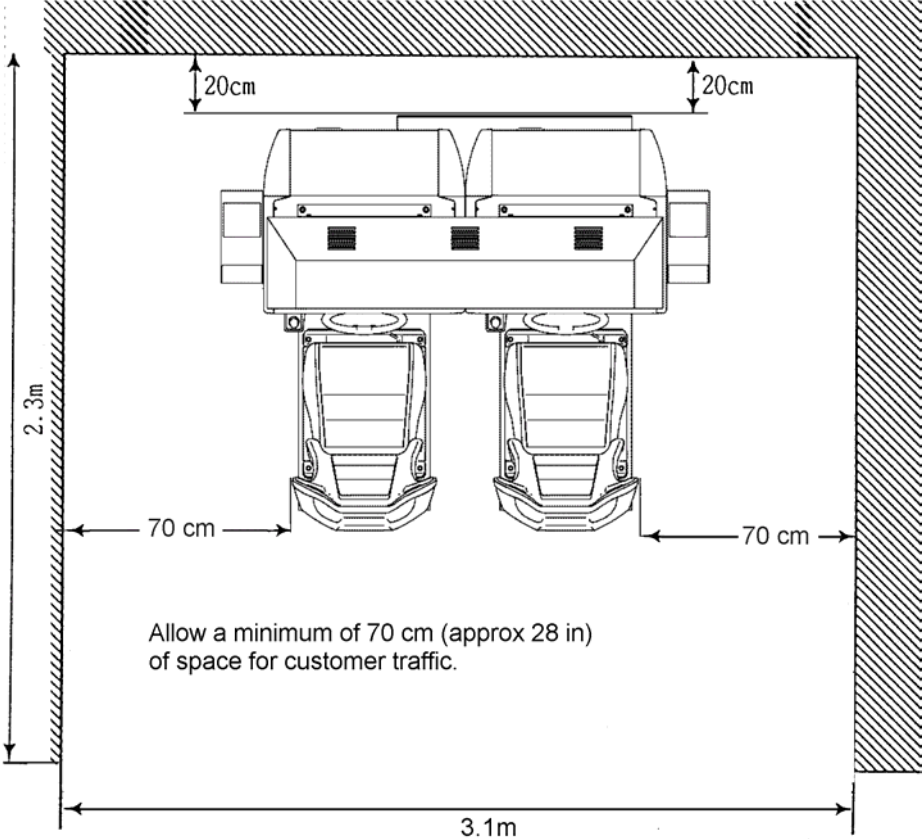



- Ensure that the mains lead is not damaged. If the mains lead is damaged in any way there could be a danger of electric shock or a fire hazard.
- Ensure that the power supply is fitted with circuit protection. Using the power supply without circuit protection is a fire hazard.

### **3.2. Coin Handling**

Standard Sega machines are fitted with a SR3 coin mechanism, however, as a service to our customers Sega machines can be supplied with no coin mechanism or door allowing the customer to fit a coin handling option from the approved list. Fit only the coin handling arrangements detailed below and follow the instructions provided in Section 3.7.6. Failure to fit the coin handling options detailed or failure to follow the installation instructions will render the machine, under the CE marking directive, void.

Approved coin handling options:

- Coin controls SR3
- Generic mechanical
- Mars (MS111B1 and ME115)
- SECI RM4-G20

### 3.3. Name Of Parts

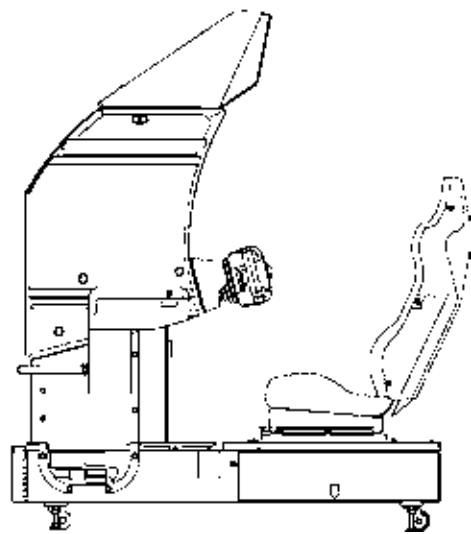
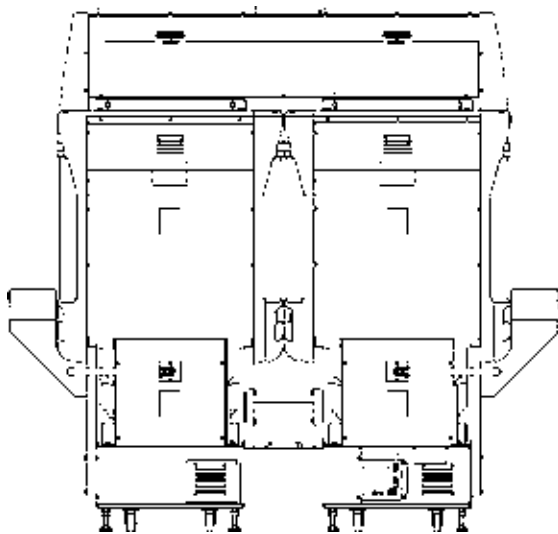

	Width (cm)	Length (cm)	Height (cm)	Weight (kg)
*COCKPIT (EACH)	101	165	152	224
COIN CHUTE TOWER	27	33	57	15
BILLBOARD	160.9	61.7	35.4	36
When Assembled	202	170	186.4	492 Approx.



### 3.4. Accessories

The machine is supplied with an installation kit. Please ensure the following parts are supplied:

ITEM	PART NO.	QTY	DESCRIPTION
1	FZR-0200UK	1	ASSY BILLBOARD
2	FRI-0300UK	1	ASSY COINCHUTE TOWER FRI
3	ORT-0500UK	1	ASSY WIRE COVER ORT TWIN
4	DYN-0013	1	JOINT PIPE
5	DYN-0006XUK	1	AC COVER B
6	SRT-0018UK	1	AC COVER C
7	DYN-0019UK	1	AC COVER D
8	RAL-XXXX-14UK	1	TIE BRACKET RALLY
9	SPG-0008	2	BILLBOARD HOLDER
10	422-0911UK	1	PLAY INSTR FZR TWIN MULTI
11	422-0912UK	2	SUB INSTR FZR TWIN MULTI
13	PK0347	1	INST KIT BOX FZR TWIN
15	FZR-0022-01	2	STICKER CARD SLOT FZR B ENG
16	601-11334-01	3	CARD PACKAGE FZR ENG
17	601-11050-91	2	CLEANING KIT
18	220-5753	1	VOL CONT B-5K OHM (TOCOS)
19	PK0343	0.5	PALLET INST KIT
20	FZR-0020UK	2	STICKER CARD SLOT FZR C MULTI
21	FZR-1297UK	2	STICKER MEMORY CAUTION MULTI
22	FZR-2024UK	2	STICKER MEMORY SLOT LWR MULTI
101	440-CS0186UK	2	STICKER C EPILEPSY MULTI
104	OS1241	6.5	TAPE RF20 XWEAVE 50mmX50M ROLL
201	030-000825-SB	20	M8X25 BLT W/S BLK
202	068-852216-0B	20	M8 WSHR 22OD FLT BLK
203	000-P00412-WB	15	M4X12 MSCR PAN W/FS BLK
204	050-F00400	3	M4 NUT FLG SER PAS
401	420-5827	1	SERVICE MANUAL SANWA 31K
402	420-6770-01UK	1	SERVICE MANUAL FZR TWIN
403	OS1019	2	SELF SEAL BAG 9X12.3/4
404	540-0006-01	1	WRENCH M4 TMP PRF
405	540-0007-01	1	WRENCH M5 TMP PRF
406	540-0009-01	1	WRENCH M8 TMP PRF
407	220-5484	1	VOL CONT B-5K OHM
408	SAECE-xxx	1	DECLARATION OF CONFORMITY
409	514-5078-5000	2	FUSE 5X20 CERAMIC SB 5000mA
411	420-6620UK	1	SERVICE MANUAL GD ROM SYSTEM
416	509-6036	1	SW MICRO MATSUSHITA AM51615A7
418	220-5775	1	VOL CONT B-10K OHM W/BD

Item 404-406 - Tamper-proof TORX wrench.

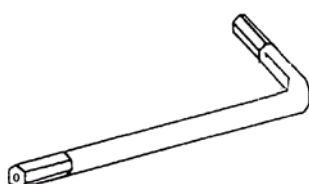

### 3.5. Shipping The Game Board and GD-ROM Drive

Observe the following precautions when sending the TRIFORCE or GD-ROM drive out for servicing or repairs.

The carton boxes (included) are needed to ship these parts, and should therefore be stored in a safe place to ensure that they are not lost.

- When sending parts in for repairs, they should be configured as follows:
  - (1) TRIFORCE:
    - Leave the key chip installed in the board.
  - (2) GD-ROM drive:
    - Remove the drive bracket.
    - Eject the GD-ROM disc, place it in its case, and store in a safe place.
- Remove the wire harnesses and cables from the TRIFORCE and GD-ROM drive before sending them in for repairs.
- Do not disassemble the TRIFORCE or GD-ROM drive. Place them in the carton box as is when sending them in for repairs.
- Provide a clear, detailed description of the game used and the observed problems when sending to the indicated repair center.

#### 3.5.1. How To Use The Triforce Carton Box

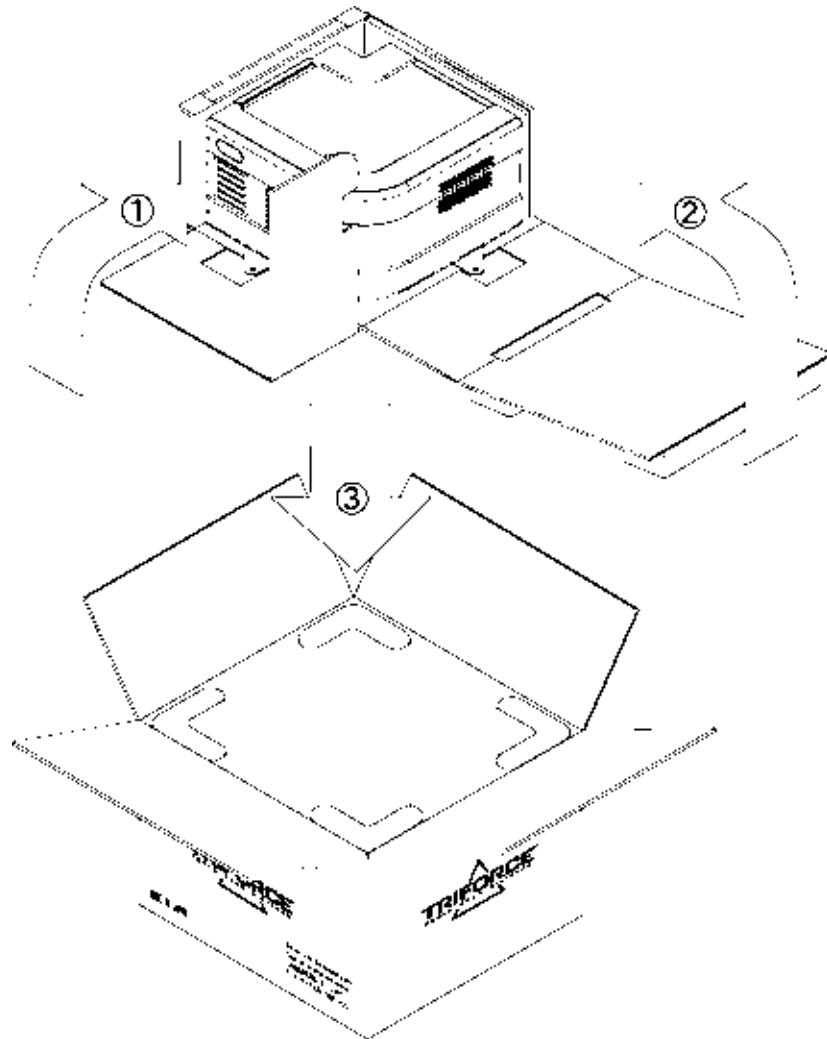

Fold the packaging in the order specified in the diagram and wrap it around the TRIFORCE, making sure that board and box are aligned correctly. Finally, place it in the carton box. Failure to wrap the product as specified in the diagram may cause damage to parts.

### 3.6. Shipping The GD-ROM Drive



- When returning the GD-ROM DRIVE for repair or replacement, be sure to package it in the original card transit box - THERE ARE NO USER-SERVICEABLE PARTS INSIDE.
- Ensure the GD-ROM Disk is removed and the GD-ROM Drive Lid is replaced on the unit, with fixing screw, before packaging. Also, remove the GD-ROM Drive Bracket and store with the four screws for reuse.
- Failure to return the GD-ROM DRIVE in this manner may invalidate the warranty.

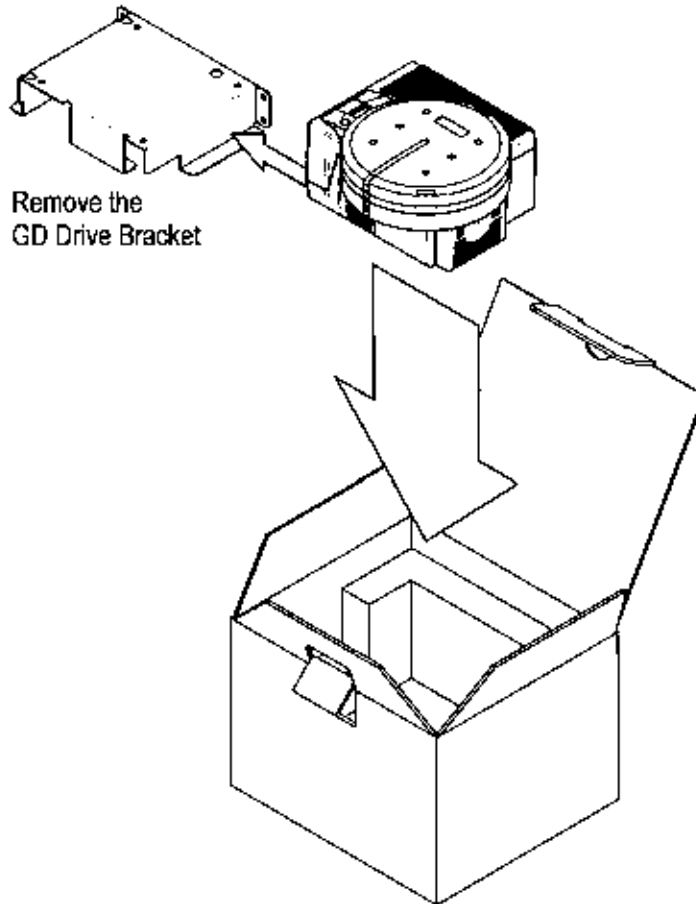

### 3.7. Assembly Instructions



- Perform the assembly by following the procedure herein stated. Failure to comply with the instructions, for example, inserting the plug into an outlet at a stage not mentioned in this manual can cause an electric shock
- Assembling should be performed as per this manual. Since this is a complex machine, erroneous assembling can cause damage to the machine, or malfunction to occur.
- Do not attempt to complete this work alone, a minimum of 2 people are required.



- Only QUALIFIED SERVICE PERSONNEL should carry out assembly.

When carrying out the assembly work, follow the procedure in the following 7 item sequence

#### STEP 1 ASSEMBLING THE COCKPIT

#### STEP 2 SECURING IN PLACE (LEG ADJUSTER ADJUSTMENT)

#### STEP 3 BILLBOARD INSTALLATION

#### STEP 4 INSTALLING THE AC COVERS (WIRE COVERS)

#### STEP 5 COIN HANDLING INSTALLATION

#### STEP 6 CONNECTION TO POWER SUPPLY

#### STEP 7 ASSEMBLY CHECK

Note that the parts contained within the installation kit are required for the assembly work.



- Fit all fixings loosely first as detailed in step 1, then position all components before finally tightening fixings at step 6.

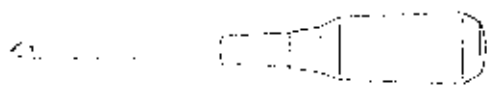

Phillips type screwdriver

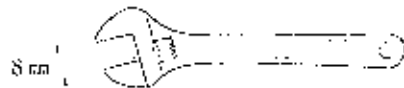

8mm WRENCH (for M3 hexagon bolt)

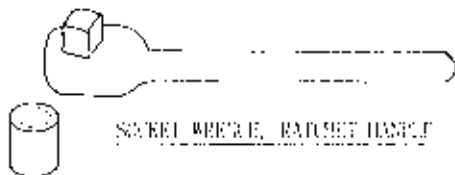

SOCKET WRENCH RATCHET HANDLE

24mm  
- 17mm

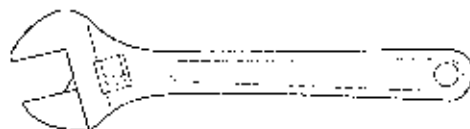

WRENCH (for M16 - M10 hexagon bolt)

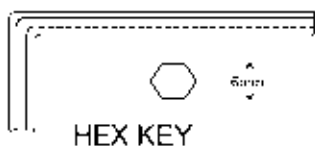

HEX KEY

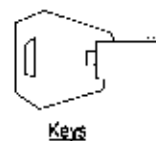

Keys

### 3.7.1. Applying The Play Instructions



- Only QUALIFIED SERVICE PERSONNEL should carry out this operation.

Supplied in the installation kit are 5 sets of play instructions in 5 languages. Select the language of your choice and apply in the following areas:

1. 422-0912UK: Instructions (on monitor mask)
2. FZR-1297UK (on top control panel over memory slot)
3. 422-0911UK: Instructions (on top of control panel)
4. FZR-0020UK Card Instructions (on card R/W lid)
5. FZR-2024UK (under memory slot)



### 3.7.2. Assembling The Cockpit



- Only QUALIFIED SERVICE PERSONNEL should carry out this operation.

1. Place the two cockpits side by side. Position the 1P cabinet, which has the IEC inlet at the left hand side when viewed facing the monitor. STICKER L is attached to the back of the 1P cabinet and STICKER R on the back of the 2P cabinet

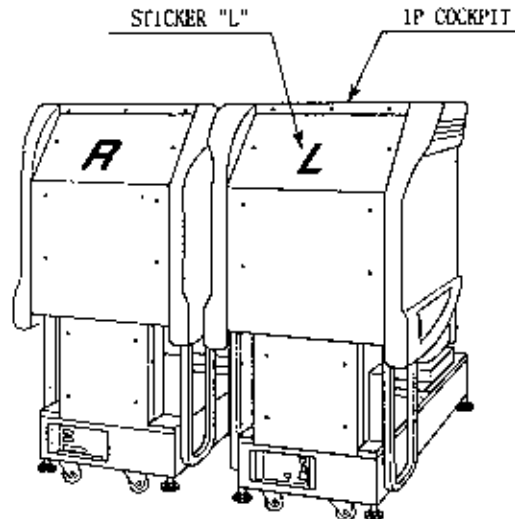

2. Install the coin chute tower in between both cabinets. Open the coin chute door and the cash door and secure with the 4 hexagon bolts from inside the doors. At this time, make sure the bolts are only loosely fitted.

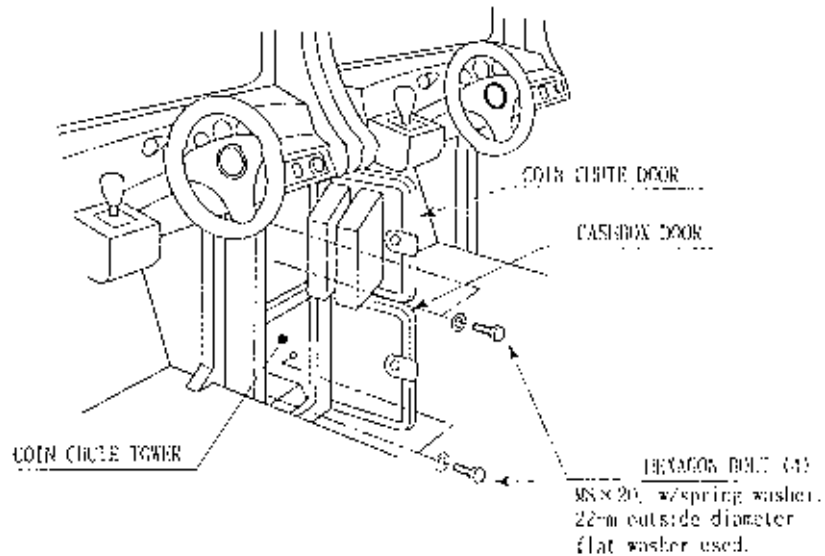

Note: Door may open in opposite way to that shown above

3. Install the joint pipe on the rear-side of both cabinets by securing with 4 hexagon bolts, at this time loosely.

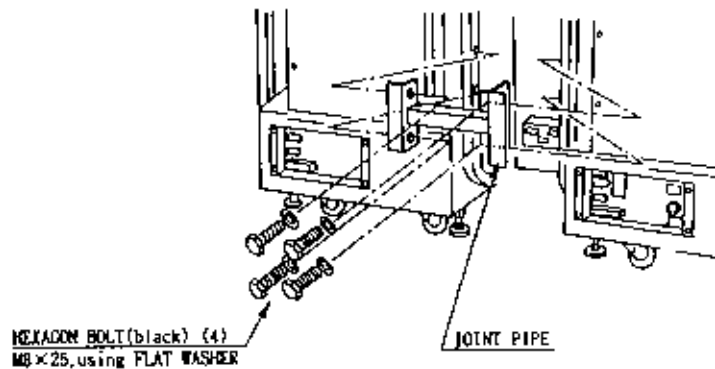

### 3.7.3. Securing In Place (Leg Adjuster Adjustment)



- Make sure all of the leg adjusters are in contact with the floor. If they are not the machines may move and cause injury. This operation requires 2 people.

- Only QUALIFIED SERVICE PERSONNEL should carry out this operation.

This machine has eight castors and eight leg adjusters. When the installation position is decided, unscrew the leg adjusters so that they raise each caster a minimum of 5mm from the floor. Make sure the machine is level.

1. Move the machine to the installation position. When installing against or close to a wall, be sure to allow an adequate space to allow the player access to the machine.
2. Make the leg adjusters contact the floor. Adjust using a spanner as shown below so that a minimum of 5mm exists between the casters and the floor. Make additional adjustment so that the machine is level.
3. Slide the joint plate onto the shafts of the indicated leg adjusters. Tighten the lock nut on all eight leg adjusters. This will secure the joint plate.

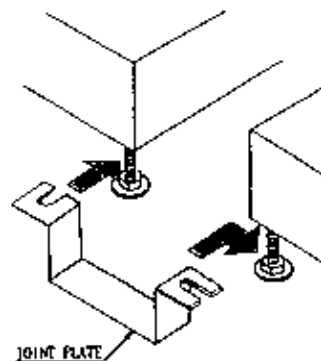
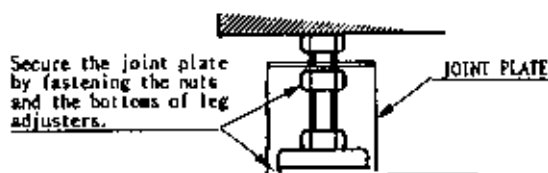
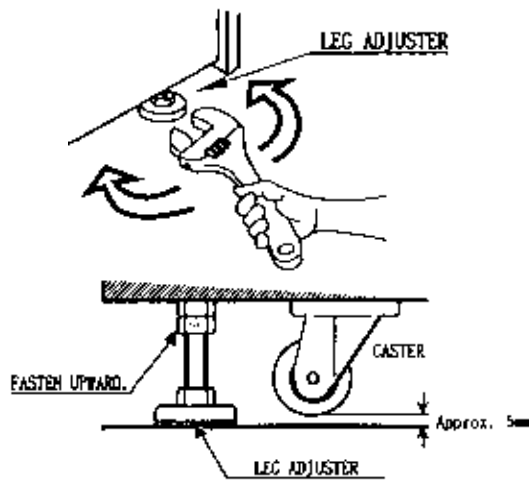
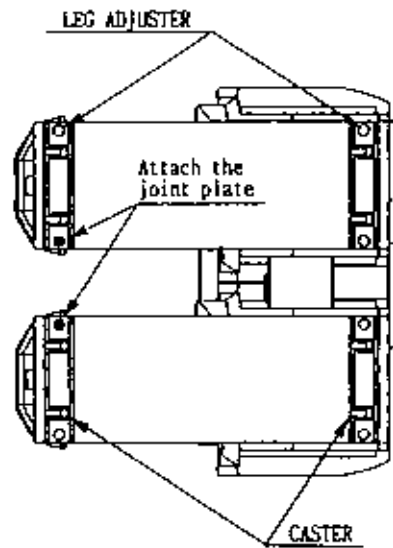

After securing the leg adjuster bolts, fully tighten all bolts temporarily attached in STEP 1 above.



Ensure adequate ventilation is maintained as detailed below

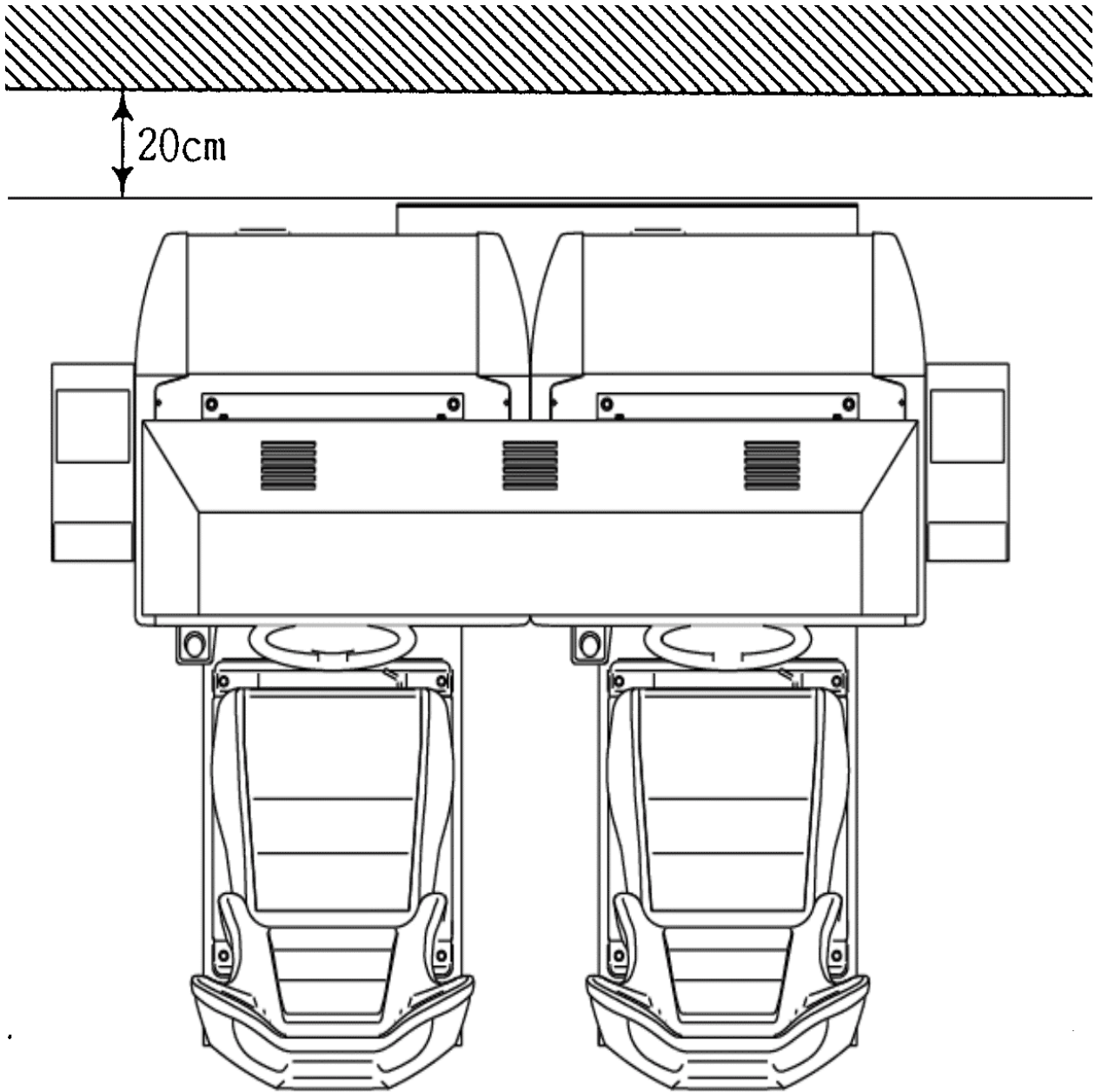



### 3.7.4. Billboard Installation



- One person alone cannot perform the installation of the billboard assembly. Seek assistance before attempting this operation

- Only QUALIFIED SERVICE PERSONNEL should carry out this operation.

1. Install the billboard base over the two cockpits.

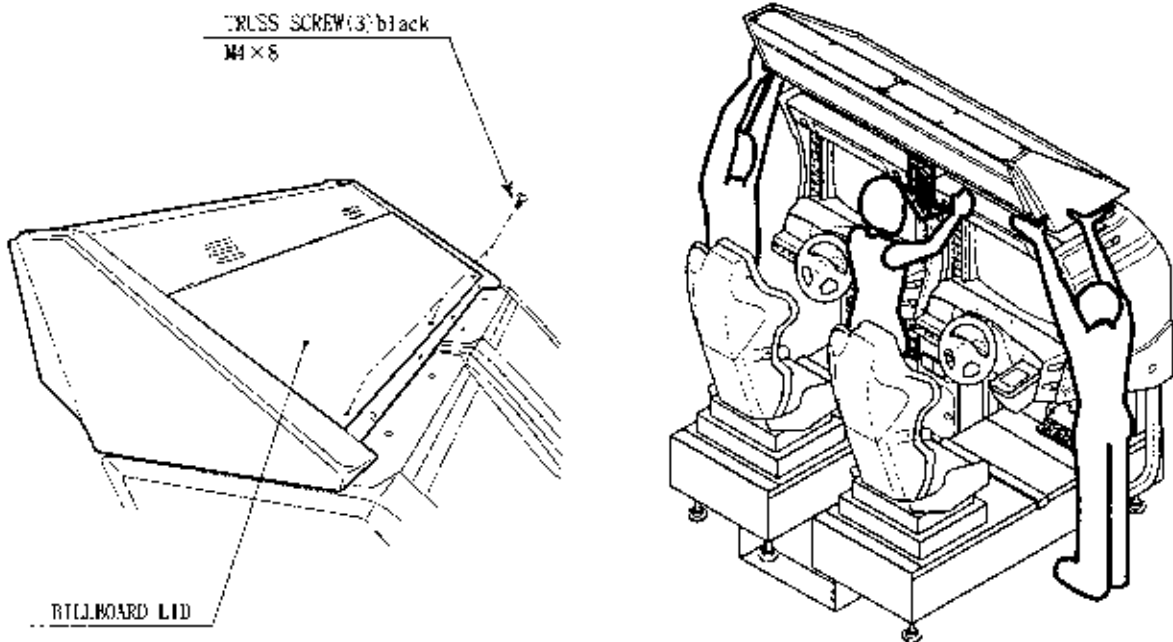

2. Mount the billboard by fitting it onto the billboard base.
3. Install the billboard holders using 2 hexagon bolts each to secure them to the cabinets.
4. Connect the wire connectors from the billboard box to the connectors on the cabinets and install the connector covers using two screws for each.

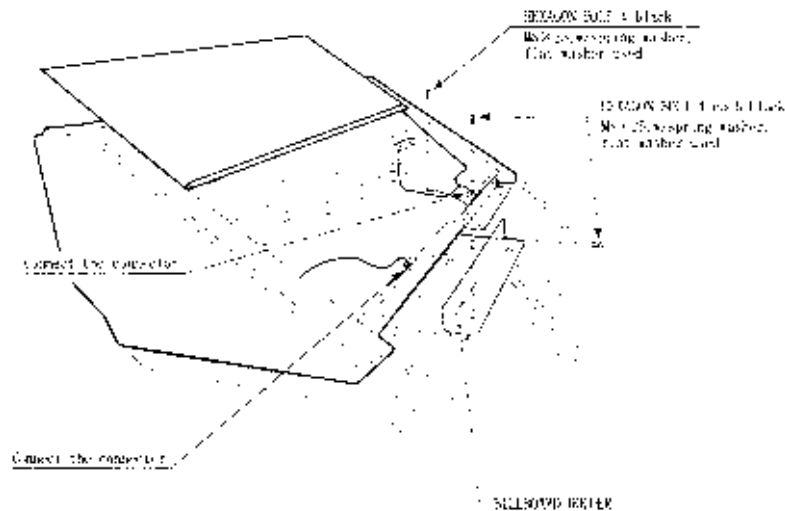

### 3.7.5. Installing The AC Covers (Wire Covers )



- Be sure that the machine is not connected to the mains supply before attempting this operation.

- Only QUALIFIED SERVICE PERSONNEL should carry out this operation.

The AC Wire Covers are used for protecting the interconnecting wiring and the fibre optic cables. When carrying out this operation be very careful so as not to trap any wire between the covers. Pay attention when handling the fibre optic cables as excessive bending may cause damage.

1. Attach AC Cover A to the rear of the cabinet using 5 screws.
2. Make all the wiring connections between the two cockpits and the Coin Chute Tower. The wiring connectors are colour coded and cannot be fitted into the wrong size connectors. Do not force any connectors together.
3. Connect the earth wires between the two AC Brkts, the AC Covers and the Coin Chute Tower.
4. Insert the fibre optic cables into the fibre optic connectors. Ensure that the "RX" connection on the 1P cockpit is connected to the "TX" connector on the 2P cockpit. The other fibre optic connects the "TX" connector of the 1P cockpit to the "RX" connector of the 2P cockpit.
5. Insert AC Cover B into AC Cover A from above and secure using 2 screws. Be sure not to trap any cables.
6. Secure AC Cover C and AC Cover D using 4 screws each.

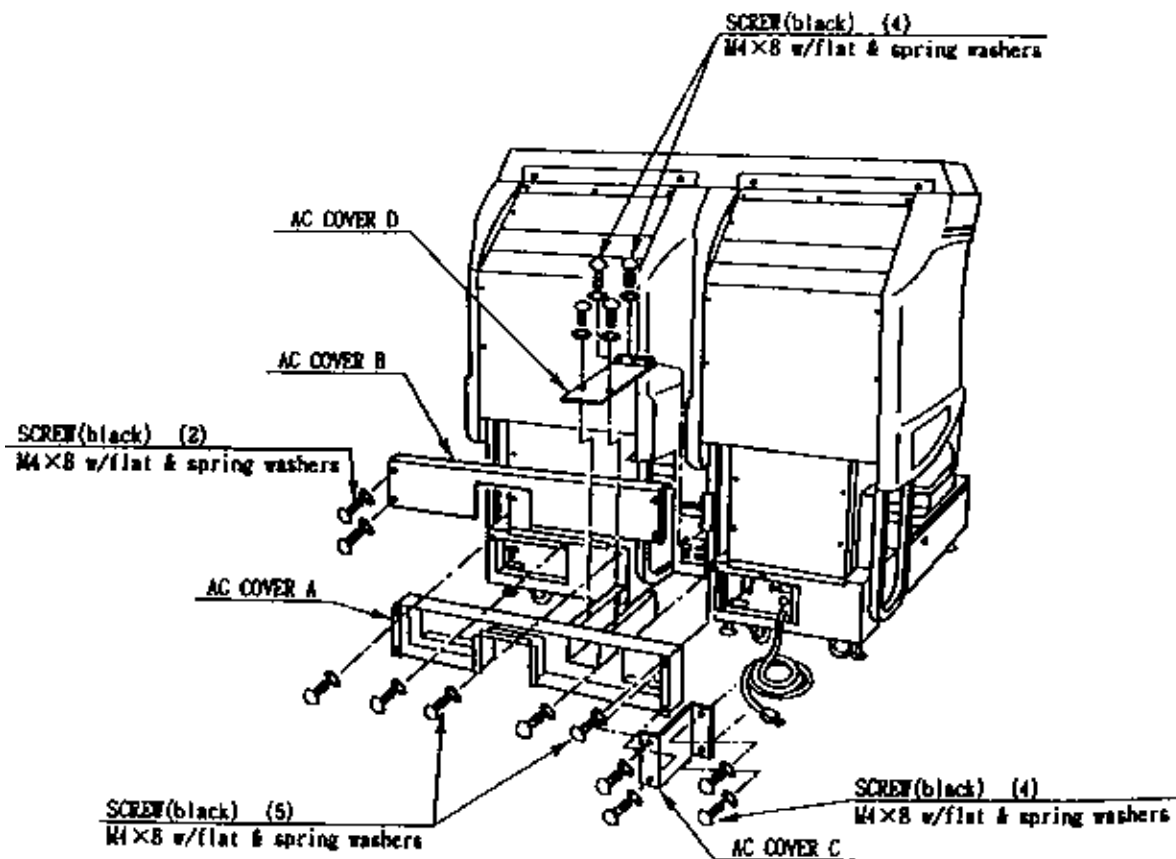

### 3.7.6. Coin Handling Installation



- Only QUALIFIED SERVICE PERSONNEL should carry out this operation.

When fitting the coin mechanism to the door please refer to the specific manufacturers installation instructions for that coin mechanism. To fit the door to the machine, follow the procedure below.

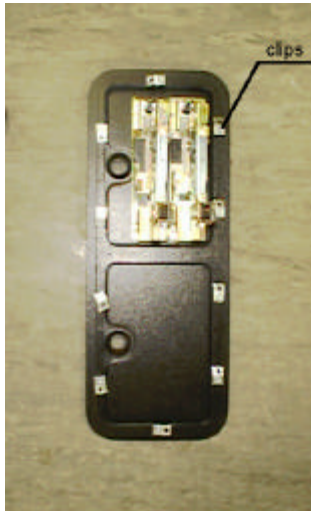

- Loosen all of the bolts on the frame, which secure the clips.
- Turn all clips in towards the door.



- Position the door into the aperture in the machine.
- Turn the clips around so that they will hold the door in the machine.
- Tighten all of the bolts.

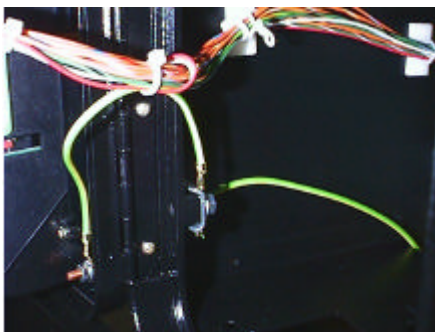

- Ensure that the door is earthed to the frame and the frame is earthed to either the VTS bracket or the coin chute tower.

### 3.7.6.1.Wiring Connections.

COIN MECH	LOOM	INSTALLATION
C220B	LM1006IDC LM1006LAMP-0.1	<ul style="list-style-type: none"> <li>Attach the lamp holder to the bracket on the coin return button.</li> <li>Attach one 15-way connector to the C220 coin mech.</li> <li>Attach the other 15-way connector to Validator A on the credit board.</li> <li>Attach the 2-way connector to 'LAMP' on the VTS board.</li> </ul>
GENERIC MECHANICALS	LM1008 LM1008-LAMP	<ul style="list-style-type: none"> <li>Fit the two lamp holders behind the coin return buttons.</li> <li>Attach the blue cable and orange cable to one mech's microswitch switch.</li> <li>Attach the blue/green cable and orange/green cable to the other mech's microswitch.</li> <li>Attach the 2-way mate and lok plug to the 2-way mate and lok cap provided.</li> <li>Attach one 15-way connector to Validator A and the other to Validator B on the credit board</li> </ul>
MARS MS111B1 MARS ME115	LM1007 LM1008-LAMP	<ul style="list-style-type: none"> <li>Fit the lamp holder to the bracket behind the coin return button.</li> <li>Fit one of the 13-way connectors to the coin mech.</li> <li>Fit the other 13-way connector to Validator A on the credit board. Note the 13-way connector is keyed and this key must coincide with the key on the credit board.</li> </ul>
SECI, C120, SR3	OWN LOOM AND LM1006LAMP-0.1	<ul style="list-style-type: none"> <li>Attach the lamp holder to the bracket on the coin return button.</li> <li>Attach the 2- connector to 'LAMP' on the VTS board.</li> <li>Attach the validator's own loom to position A on the credit board</li> </ul>

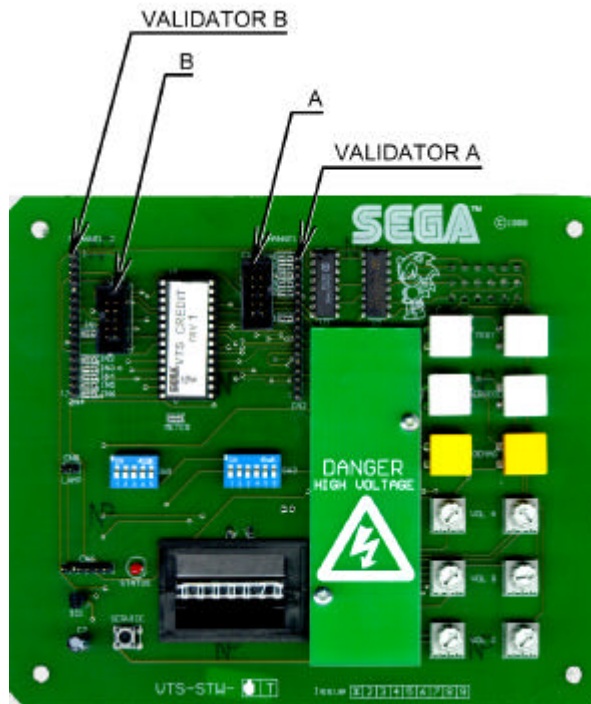

VTS credit board assembly

### 3.7.7. Communication Cables

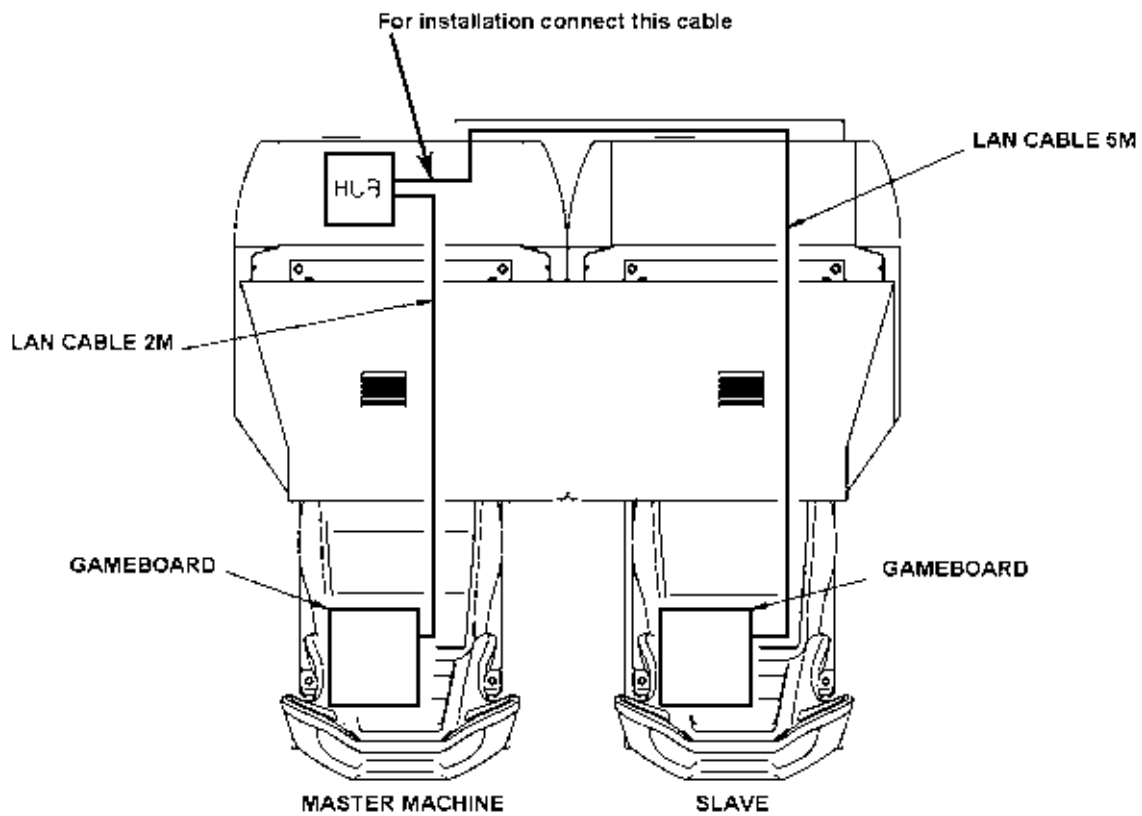

The master (left) machine's LAN cable will come pre-connected to hub.

Connect the slave machine's LAN cable (bundled up at the back in a loop) across via the AC cover to the hub of the master machine and connect to one of the hub's ports.

For machine set-up refer to Section 5.2.10.5.

### 3.7.8. Connection To The Power Supply



- This operation may only be carried out once the machine has been completely assembled.
- Only QUALIFIED SERVICE PERSONNEL should carry out this operation.

The AC Unit is located on the rear of the 1P cockpit. Using the power lead supplied connect this to the mains socket at the wall.

1. Turn the mains switch on.
2. Turn the switch on the AC bracket on.
3. Once power is turned on, the fluorescent lamp lights up. The Start System Screen displays after a lapse of several seconds. This is followed by the screen that indicates that the network is currently being checked if the communication mode has been set. If there is a bad or improper communication connection, each screen will not proceed to the next, remaining on the currently Network Check Screen. If this occurs, resolve the error according to the instructions in this document.
4. If the communication mode has not been set or the communication check ends normally, the Motor Check Screen returns. While the Motor Check Screen is on-screen, the steering wheel can move either clockwise or counter clockwise. If you touch the wheel, the motor check is hindered and the game will not operate normally. So, you must not touch it at this time. Failures are displayed, if found. Resolve the errors according to the instructions in this document.
5. Once all the above steps have been completed, the Advertise Screen displays and voices are output through the left and right loudspeakers, unless you have set the machine so that no voices are output during the Advertise mode.
6. This product retains the number of credits and the ranking data even after the power is turned off. It does not retain data about the fractional number of coins (i.e., the number of coins not reaching one credit) or the bonus adder count.

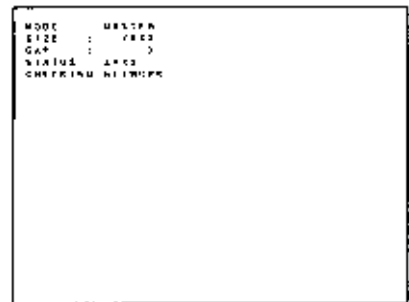
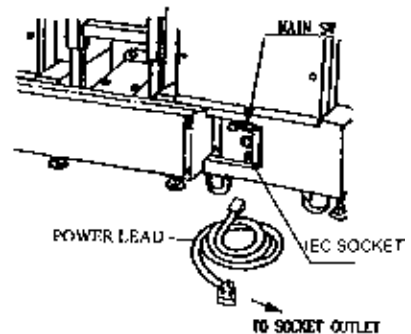





### 3.7.9. Assembly Check

In the Test Mode, ascertain that the assembly has been made correctly and IC BD is satisfactory (see Section 5.2.1).

In the test mode perform the following test:

#### 3.7.9.1.Memory Test

Selecting RAM TEST or MEDIA BOARD TEST from the menu screen in System Test mode will cause the machine to automatically perform a test of memory on the game boards. If GOOD is displayed next to the number of each memory segment, the game boards are working properly.

Select SYSTEM INFORMATION to display information on the main game board and the media board. If the information is displayed correctly, this indicates that the game boards are functioning properly.

```
RAM TEST

AUX MEMORY          GOOD

TEST BUTTON TO EXIT
```

```
MEDIA BOARD TEST 1/2

DIMM BOARD(TYPE 3)
VERSION ****
STATUS GOOD
CHECKING 100%

DIMM TEST
DIMM0 - GOOD
DIMM1 - NONE
GD-ROM - GOOD

PRESS TEST BUTTON TO EXIT
```

```
MEDIA BOARD TEST 2/2

NETWORK BOARD
VERSION ****
STATUS GOOD
CHECKING 100%
NETWORK BOARD TEST
RAM CHECK _ GOOD
-- COMPLETED --

PRESS TEST BUTTON TO EXIT
```

```
SYSTEM INFORMATION
MAIN BOARD
REGION ****
BOOT VERSION ****
FIRM VERSION ****
FPGA VERSION ****
SERIAL NO. *****

MEDIA BOARD
DIMM BOARD(TYPE 3) + GDROM
MEMORY SIZE 512MB
FIRM VERSION ****
SERIAL NO. *****

NETWORK BOARD
FIRM VERSION *****

PRESS TEST BUTTON TO EXIT
```



### 3.7.9.2.Input Test

Select INPUT TEST from the menu screen in either System Test mode

JVS TEST	
INPUT TEST	
NODE	1/1
SYSTEM	00
PLAYER 1	1 0000
PLAYER 2	2 0000
COIN 1	1 0000
COIN 2	2 0000
ANALOG	1 0000
ANALOG	2 0000
ANALOG	3 0000
ANALOG	4 0000
ANALOG	5 0000
ANALOG	6 0000
ANALOG	7 0000
ANALOG	8 0000

INPUT TEST				
STEERING	X	0 (~FF)	SERVICE	OFF (ON)
STEERING	Y	0 (~FF)	TEST	OFF (ON)
PADDLE	LEFT	OFF (ON)		
PADDLE	RIGHT	OFF (ON)		
BOOST		OFF (ON)		
GAS		0 (~FF)		
BRAKE		0 (~FF)		
START BUTTON				
VIEW CHANGE	1	OFF (ON)		
VIEW CHANGE	2	OFF (ON)		
VIEW CHANGE	3	OFF (ON)		
VIEW CHANGE	4	OFF (ON)		

PRESS TEST AND SERVICE BUTTON TO EXIT

### 3.7.9.3.Sound Test

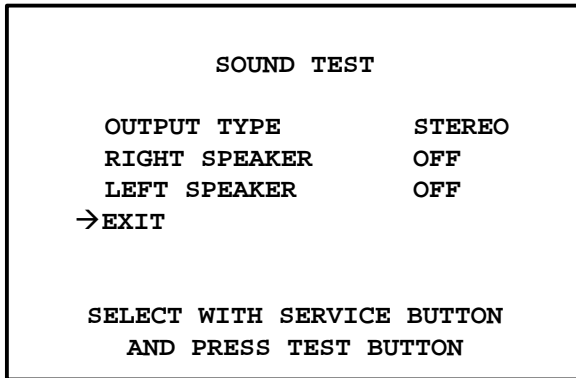

In the system test mode, selecting SOUND TEST causes the screen (on which sound related BD and wiring connections are tested) to be displayed. Check if the sound is satisfactorily emitted from each speaker and the sound volume is appropriate.

### 3.7.9.4.CRT Test



- Only QUALIFIED SERVICE PERSONNEL should carry out this operation.

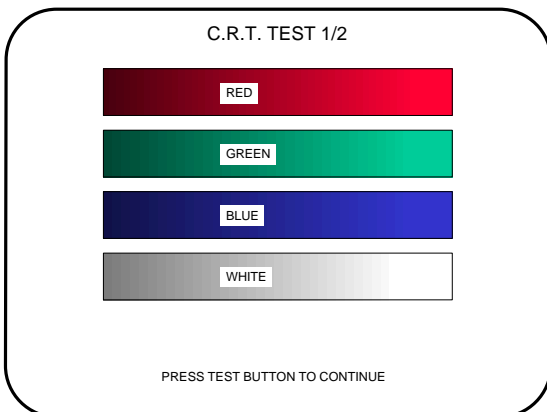

In the TEST mode select CRT test to check the screen is satisfactory.

Although the projector has been set up at the factory before shipment, check to see if the screen needs adjustment.

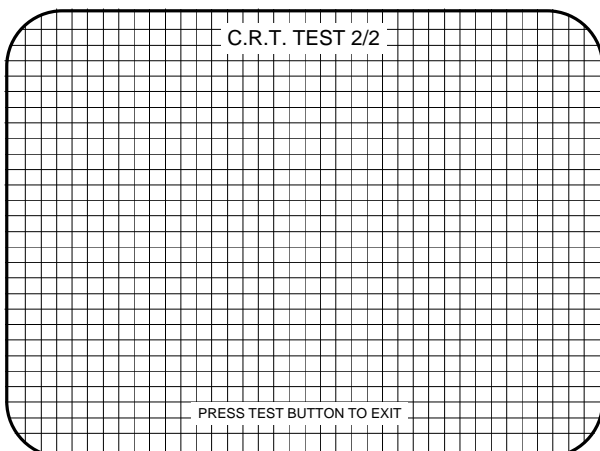

### 3.7.9.5.Output Test

OUTPUT TEST	
START BUTTON	OFF (ON)
VIEW CHANGE 1	OFF (ON)
VIEW CHANGE 2	OFF (ON)
VIEW CHANGE 3	OFF (ON)
VIEW CHANGE 4	OFF (ON)
BOOST	OFF (ON)
STEERING	
CENTER	OFF (ON)
LEFT	OFF (ON)
RIGHT	OFF (ON)
→EXIT	
SELECT WITH SERVICE BUTTON	

Select OUTPUT TEST from the menu screen in Game Test mode to bring up a test screen for the output devices (lamps, etc.).  
If each output device activates correctly, the output devices and their wiring connections are working properly.

Perform the above inspections also at the time of monthly inspection

### 3.7.10. Moving The Machine



- When moving the machine, be sure to remove the plug from the power supply. Moving the machine with the plug inserted can cause the power cord to be damaged, resulting in a fire or electric shock.
- When moving the machine, retract the leg adjusters fully and ensure the casters make contact with the floor. During movement pay careful attention so that the casters or leg adjusters do not damage any other cabling laid on the floor. Such damage could result in a fire or electric shock.
- Don't push the cockpit cabinets from the side, as they may topple and cause damage.
- Don't put excessive pressure on the glass or plastic components as damage or personal injury may result if there is a breakage.



- Only QUALIFIED SERVICE PERSONNEL should carry out this operation.

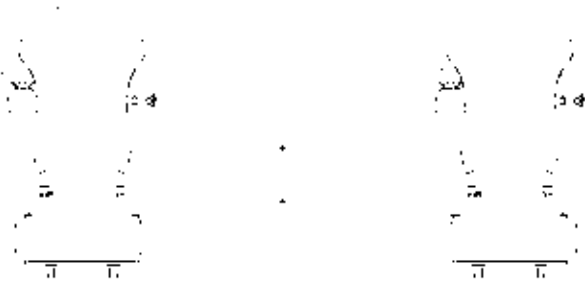

Disassemble the cabinet into its components if transporting up or down step level changes!



Do not push an individual cockpit from the side!

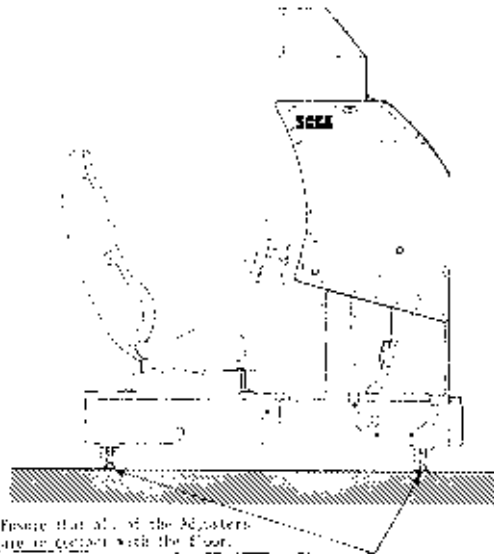

### 3.8. Fuses



- Never touch places other than those specified. Touching places other than those specified can cause electric shock and short circuit. Disconnect the machine from the supply before attempting the replacement of any fuse.

- Only QUALIFIED SERVICE PERSONNEL should replace FUSES.

There are a number of fuses used on this machine to protect the user and the machine from damage. Only replace the fuse once you have remove the cause of its failure. Detailed below is a list of the fuses used, their location and if relevant PCB reference:

PART NUMBER	LOCATION	TYPE & DETAILS	QTY PER COCKPIT
514-5078-5000	IEC INLET (EP1302)	5x20 HRC SB 5000mA	1
514-5078-6300	838-11856CE-02	5x20 HRC SB 6300mA	1
514-5078-4000	400-5397-01 (F1)	5x20 HRC SB 4000mA	1
514-5078-6300	838-13578 (F1)	5x20 Ceramic SB 6300mA	1
514-5080-15000	838-14174(F1)	32x6.35 HRC SB 15000mA	1
514-5078-2500	838-14174(F2)	5x20 HRC SB 2500mA	1
514-5033-5000	400-5421-07512 (F11)	5x20 Glass T 125v 5 A	1

There are also fuses located on the Monitor PCB. Refer to the relevant Monitor manual supplied to reference these fuses.

### 3.9. Maintenance



- Only Qualified Service Personnel must carry out maintenance.
- Ensure that the mains power is switch OFF and disconnected before attempting any work.



- The CONTROL PANEL ASSEMBLY is heavy and may cause injury or damage to the machine if dropped. Use an assistant when removing and replacing it.



- In order to prevent an electric shock and short circuit, be sure to turn power off before performing work by touching the interior parts of the product.
- Be careful not to damage the wires. Damaged wires may cause electric shock or short circuit or present a fire risk.
- Do not touch undesignated places. Touching places not designated can cause electric shock or short circuit.
- This work should be performed by the site maintenance individual or other skilled professional. Performing work by non-technical personnel can cause electric shock hazard.
- Do not perform work other than those specified in this Manual in order to prevent accidents during performing work and operation after performing work. Performing work not specified in this Manual may require special training for this product. If performing work other than those stated in this manual is required for repair, contact the offices herein stated in this manual or where you purchased the product from and ask for repair or inquire how to repair.
- Be very careful when soldering. Handling a soldering iron carelessly may result in a fire or a burn.
- Be extremely careful when heating the heat-shrinkable tube. Failure to do so may result in a fire or burns.



- Do not drop parts when removing them. Dropping parts may damage them or cause sudden accidents.
- To prevent accidents, more than one person must perform these operations.
- Exercise extreme caution when handling the internal parts of the Control Panel. Watch out for damage, warping and loss. The loss of just one piece may result in damage to or lead to faulty operation of the entire unit.
- When securing the plastic-made parts, do not excessively fasten screws and nuts. Failure to observe this may damage the parts and cause injury due to fragments resulting from damage.



- Be sure to perform volume's move value setting in the Volume Setting in the Test Mode after replacing or adjusting the Volume. (See Section 5.)

### 3.9.1. Removing The Control Panel

Poor handle response/lack of response when adjusting the Volume in Test Mode may be caused by faulty Volume alignment and/or a damaged Volume.

Follow the instructions below to adjust the gear alignment and/or replace the Volume.

If the Volume Shaft is rotating within its normal area of mobility, there is little chance the Volume can be damaged by rotating the handle as far as possible to the left/right. With the handle in the centre position, i.e. straight, and the Volume Shaft in the same direction shown in the diagram, attach the Volume so that it aligns properly with the gears. The recommended value of the VR is within the range 78H | 88H when the steering unit is in the straight position. In order to adjust or replace the Volume, follow the instructions below to remove the Control Panel.

A 5 mm hexagonal wrench is required for the following procedure.

1. Turn off the power.
2. A Remove the 6 hexagon socket screws from the Control Panel.

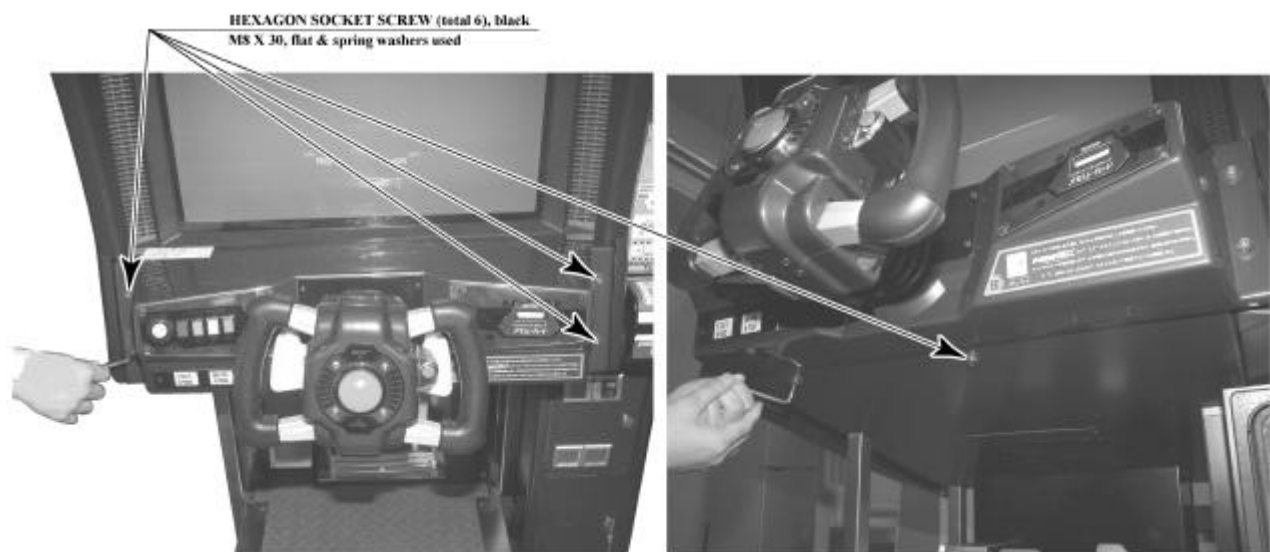

3. The mass of the control panel is approximately 23 kg. Removal and installation of the control panel should be performed by at least 2 people working together. The panel should be firmly supported using both hands.



4. Unplug the 8 connectors and re move the Control Panel. Be careful not to damage any of the wiring.

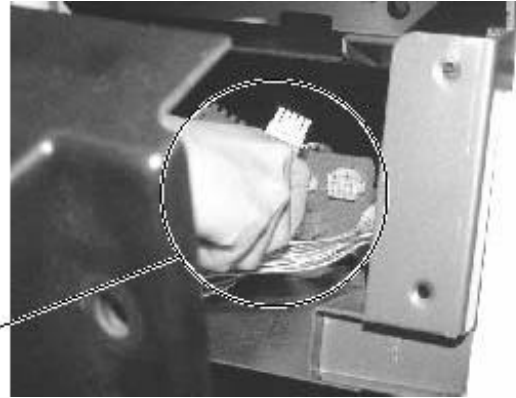

DISCONNECT CONNECTOR

### 3.9.1.1.Adjusting/Replacing The Volume

#### 3.9.1.1.1.Adjustment Procedure

1. Loosen the 2 screws that secure the VR Bracket and move the VR Bracket to adjust the angle and condition of the gear alignment.
2. Keeping the handle straight, align the gears so that the direction of the D Cut side of the Volume Shaft matches that shown in the diagram.

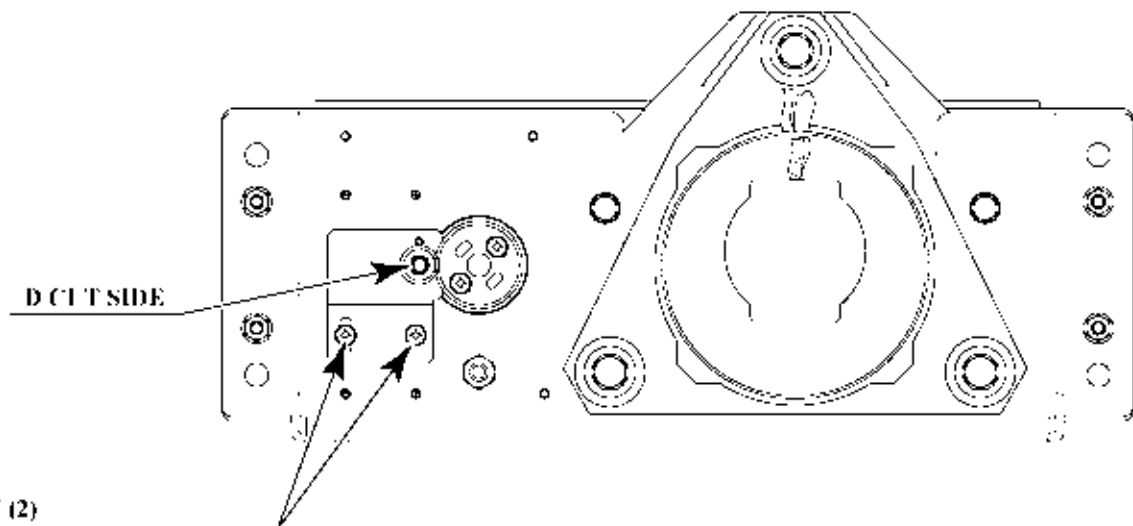

**SCREW (2)**

**M4 X 8, w/flat & spring washers**

3. Tighten the 2 screws and secure the VR Base.
4. Adjust the variable resistor settings on the Volume Setting screen (see 5.2.10.7).
5. Check to make sure the "STEERING X" value on the Input Test screen is within the range 80H+/- 8H when the steering unit is in the straight position.



### 3.9.1.1.2.Replacement Procedure

This procedure requires the following tools: Philips screwdriver for the M4 screws, 1.5 mm hexagonal wrench, 11\12mm monkey wrench, nipper, cutter, wire stripper, soldering iron and industrial dryer.

1. Remove the connectors.
2. Remove the 2 screws securing the VR Bracket and remove the entire Bracket and Volume.

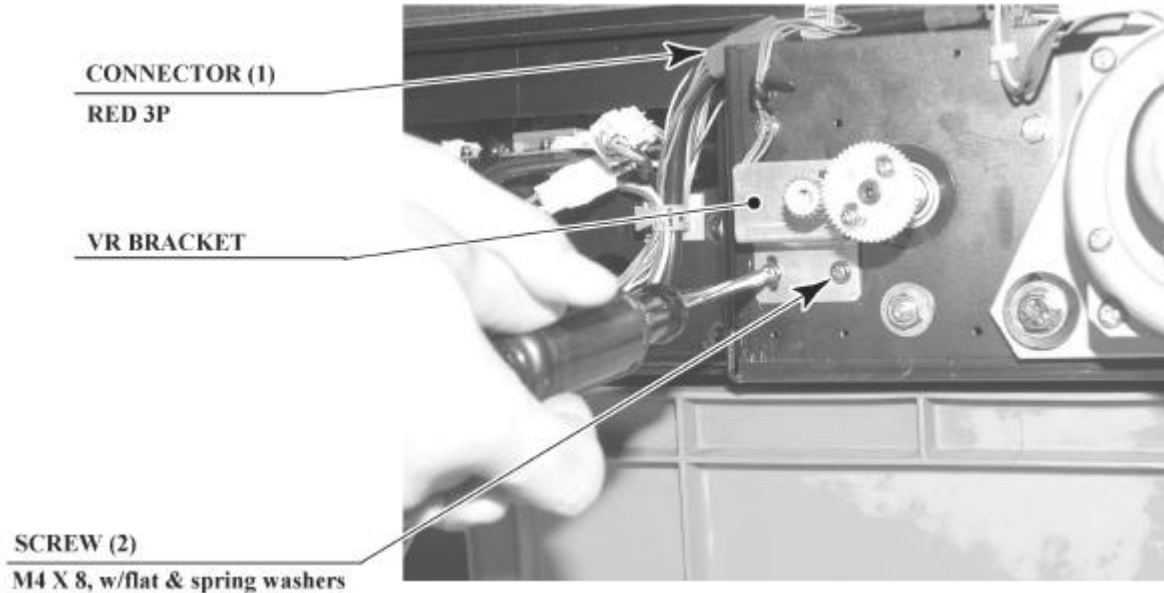

3. Loosen the 2 hexagon socket screws on the Gear and remove the Gear.
4. Remove the nut securing the VR Bracket, then separate the Volume from the VR Bracket and replace it.

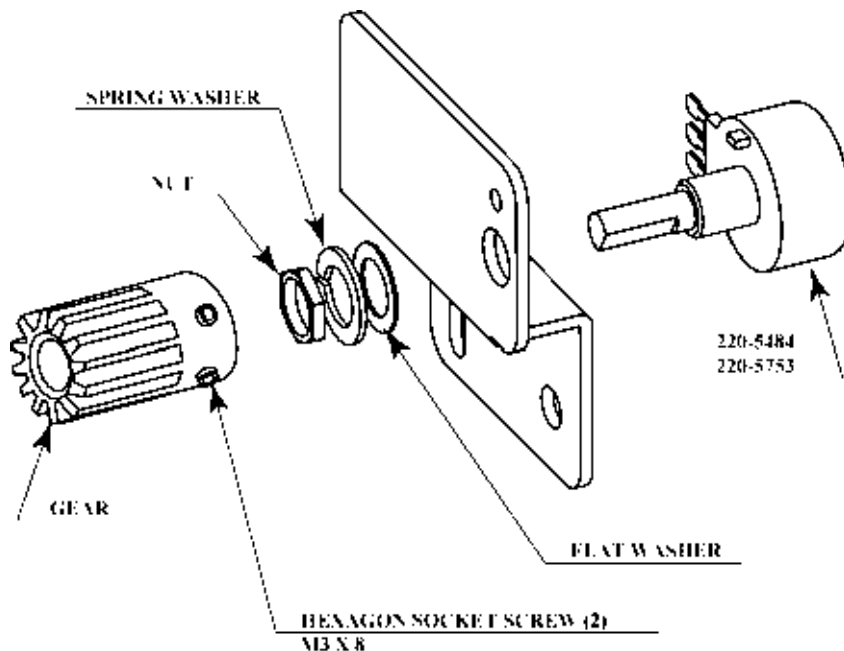

5. Adjust the variable resistor settings on the Volume Setting screen.
6. Check to make sure the "STEERING X" value on the Input Test screen is within the range 80H+/-8H when the steering unit is in the straight position.

### 3.9.1.2.Greasing



- Be sure to use the designated type of grease. If a non-designated type grease is used, components may break.
- Do not apply grease to any part of the machine other than those parts specifically indicated. Doing so may result in malfunctioning and/or deterioration of parts.
- The period for greasing specified herein is a standard. Apply greasing to the specified portions as occasion arises.
- Be sure to use a good quality, synthetic lubricant. Using a mineral-based lubricant will cause damage to the plastic parts.

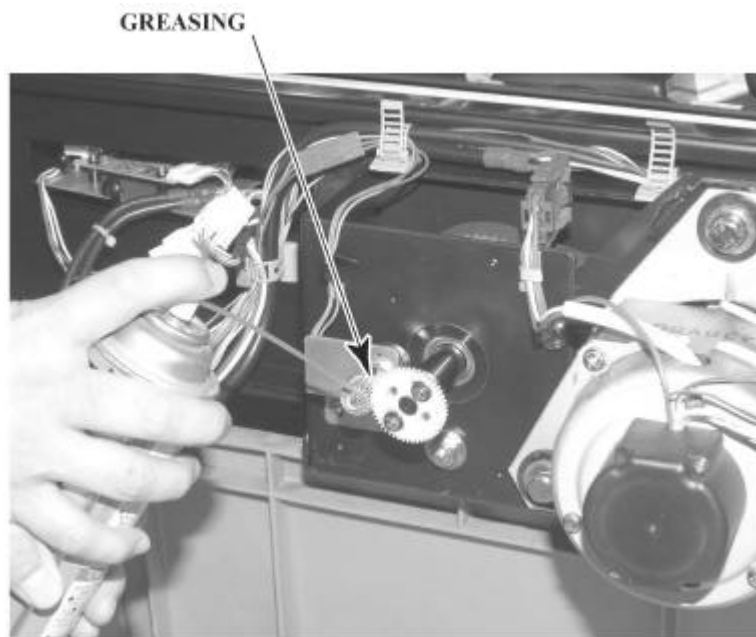

### 3.9.2. Steering Unit



- In order to prevent an electric shock and short circuit, be sure to turn power off before performing work by touching the interior parts of the product.
- Be careful not to damage the wires. Damaged wires may cause electric shock or short circuit or present a fire risk.
- Do not touch undesignated places. Touching places not designated can cause electric shock or short circuit.
- This work should be performed by the site maintenance individual or other skilled professional. Performing work by non-technical personnel can cause electric shock hazard.
- Do not perform work other than those specified in this Manual in order to prevent accidents during performing work and operation after performing work. Performing work not specified in this Manual may require special training for this product. If performing work other than those stated in this manual is required for repair, contact the offices herein stated in this manual or where you purchased the product from and ask for repair or inquire how to repair.
- Be very careful when soldering. Handling a soldering iron carelessly may result in a fire or a burn.
- Be extremely careful when heating the heat-shrinkable tube. Failure to do so may result in a fire or burns.



- Exercise extreme caution when handling the internal parts of the Steering Unit. Watch out for damage, warping and loss. The loss of just one piece may result in damage to or lead to faulty operation of the entire unit.
- When securing the plastic-made parts, do not excessively fasten screws and nuts. Failure to observe this may damage the parts and cause injury due to fragments resulting from damage.



- When adjusting or changing the variable resistor, set the variable resistor values on the Volume Settings screen and check the values on the Input Test screen in Test mode.
- After adjusting or replacing a microswitch, be sure to verify that the switch turns on and off correctly on the Input Test screen in Test mode.

If steering unit response is less than ideal and adjusting the settings on the Volume Settings screen in Test mode has no effect, the problem is most likely due to an incorrectly engaged gear, an improperly placed microswitch, or a broken variable resistor or microswitch.

Follow the steps listed below to correct the gear engagement, adjust the position of the switch, or replace the variable resistor or switch.

Refer to Section 12, "Control Panel", for instructions on how to: adjust and replace the direction control variable resistor.

### 3.9.2.1. Adjusting And Replacing The Y-Axis VR

The variable resistor that detects the forward and backward tilting operation of the steering unit is called the Y-axis steering VR. Follow the steps listed below to adjust the gear engagement or re place the VR.

In this machine, the VR will not be damaged as long as its axle is rotating within its range of motion when the handles on the machine are tilted to their maximum extent. Secure the VR so that its axle points in the indicated direction and the gear is properly engaged when the handles are not being tilted.

The recommended value of the VR is within the range 70H- 80H when the steering unit is in the horizontal position (see 5.2.10.2).

The following tools and instruments are required to perform these operations:

- 3mm diameter hexagonal screwdriver or wrench
- M4-size Phillips screwdriver
- 1.5mm diameter hexagonal screwdriver or wrench
- 10mm diameter spanner
- Soldering iron

#### 3.9.2.1.1. Adjustment Procedure

1. Turn off the power.
2. Remove the 4 hexagon socket screws around the boost button.

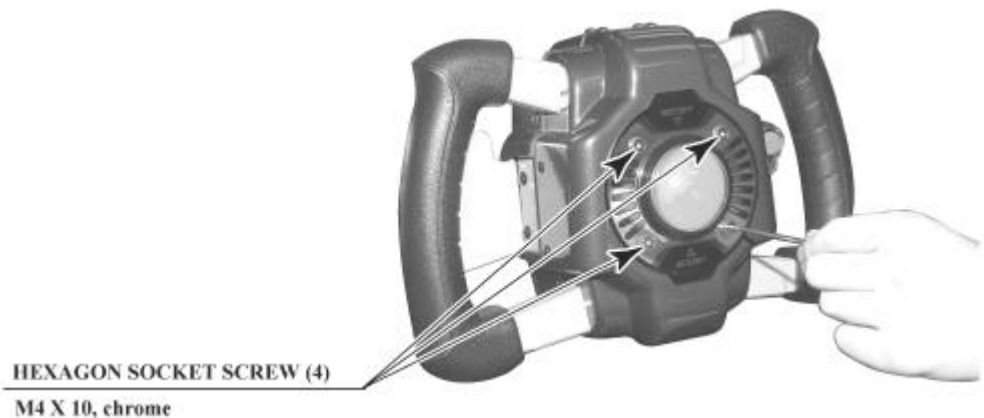

3. Remove the 4 truss screws holding the top and bottom of the front steering cover in place.

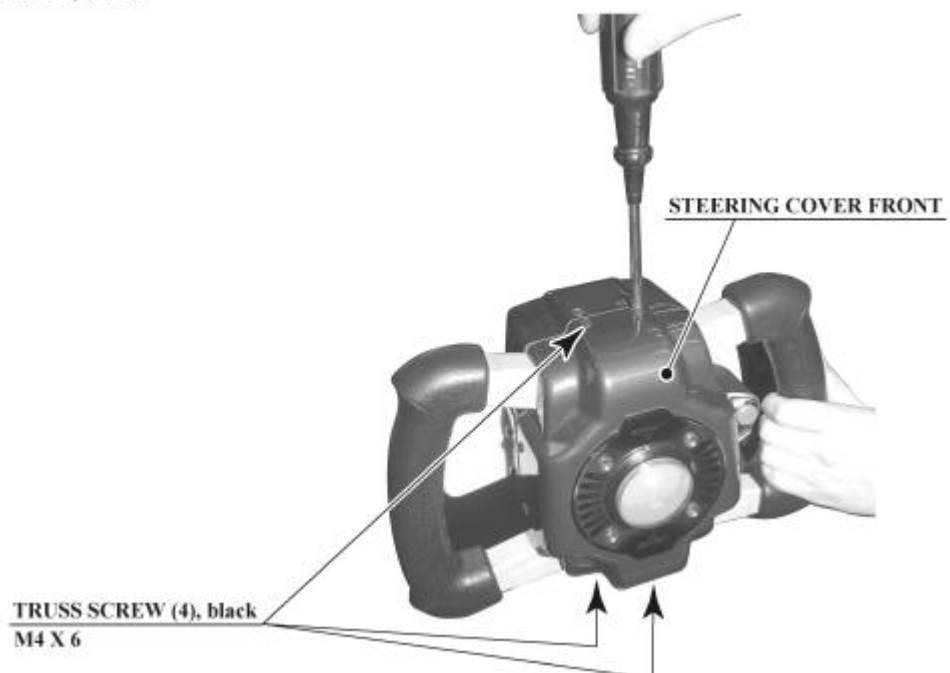

4. Remove the 4 truss screws holding the left and right sides of the front steering cover in place.

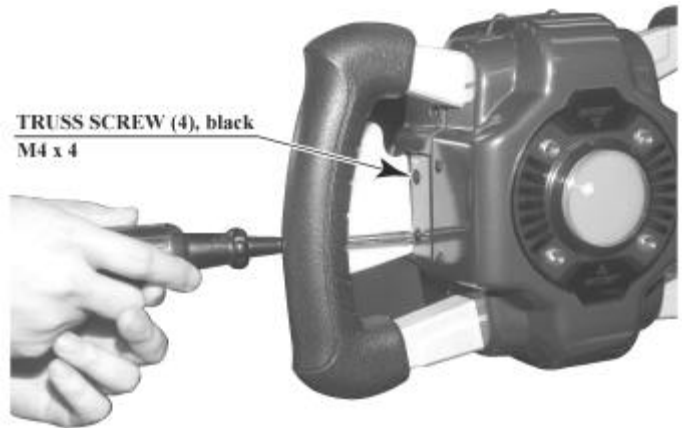

5. Detach the front steering cover. There are several wires connected to the inside of the cover. Remove the cover slowly and unplug the connectors, taking care not to damage the wiring.

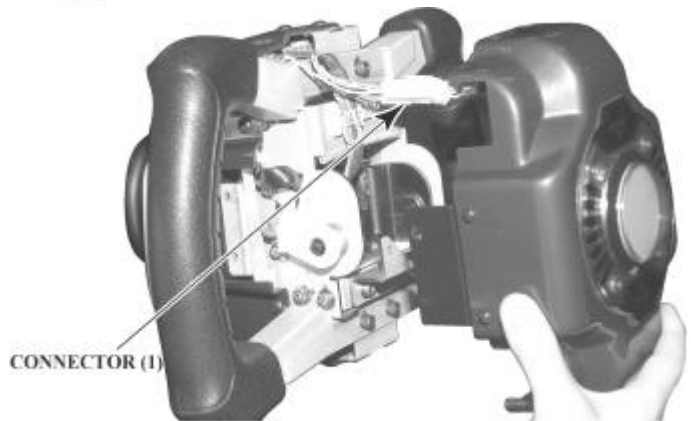

6. Remove the 4 truss screws holding the top and bottom of the rear steering cover in place.

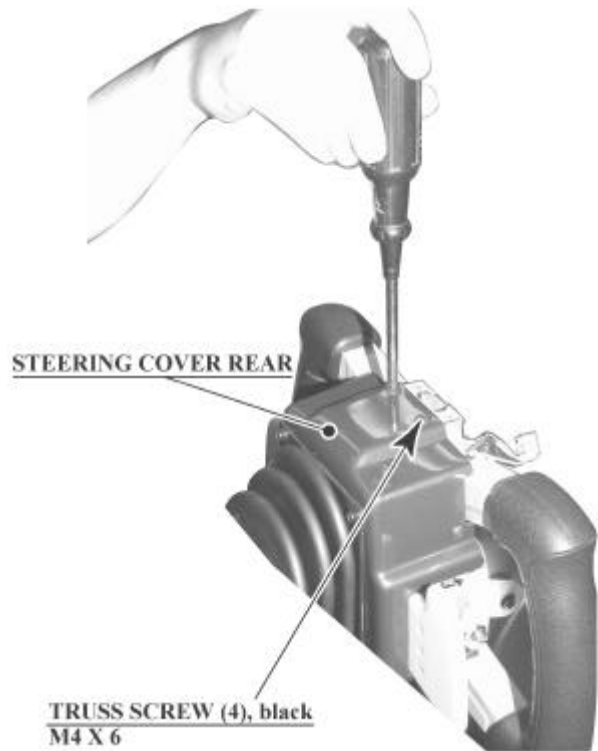

7. Remove the 4 truss screws holding the left and right sides of the rear steering cover in place.

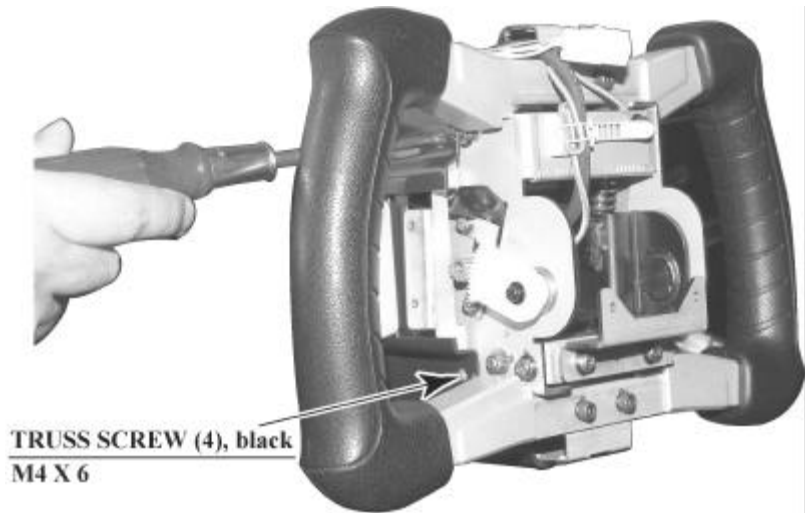

8. Push the rear steering cover towards the interior of the machine, pressing down on the accordion-fold behind the cover. The Y-axis VR should now be visible inside the cover, on the left side when facing the monitor.

NOTE: The steering unit has been removed in this photograph for better visibility. It is not necessary to remove the steering unit when performing the actual operation.

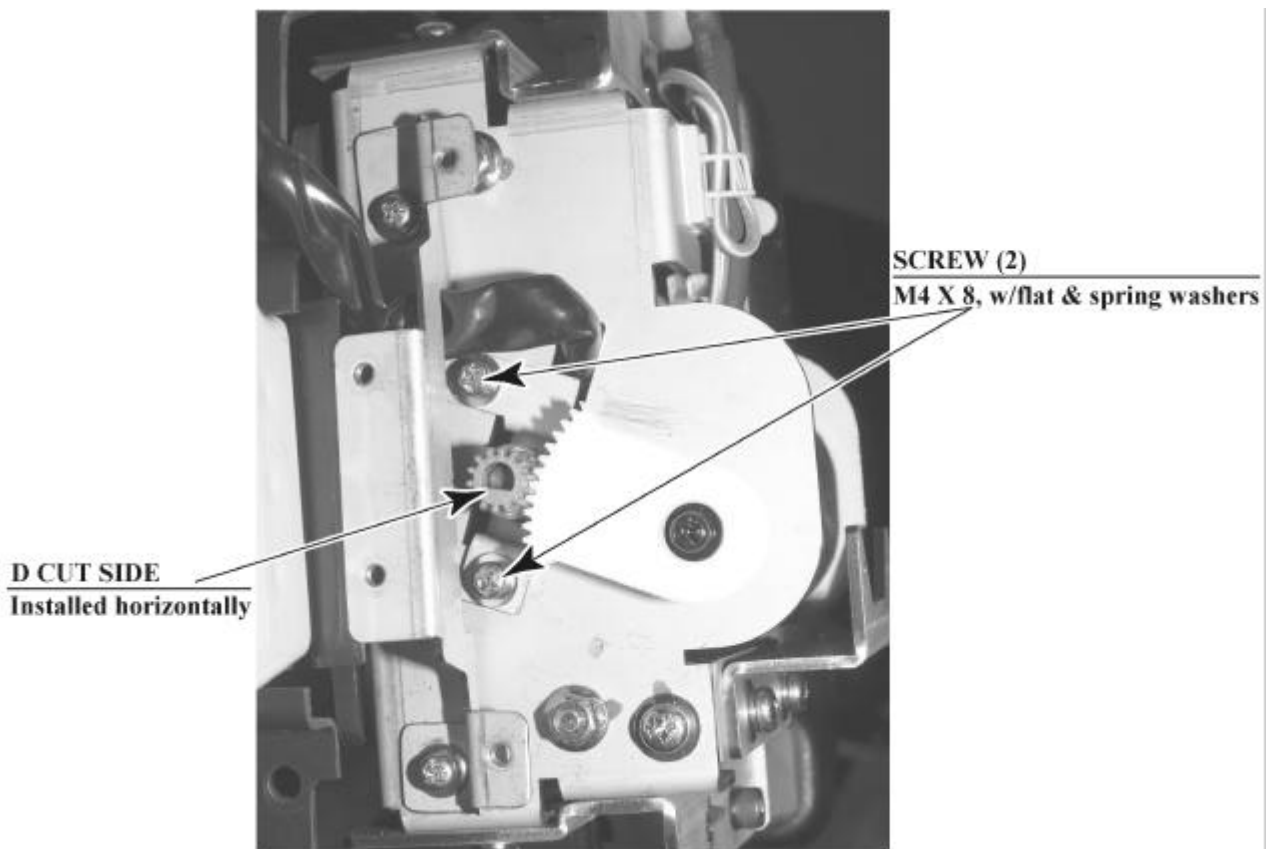

- Loosen the 2 screws holding the variable resistor bracket in place, move the variable resistor bracket, and adjust the gear engagement for angle and positioning.

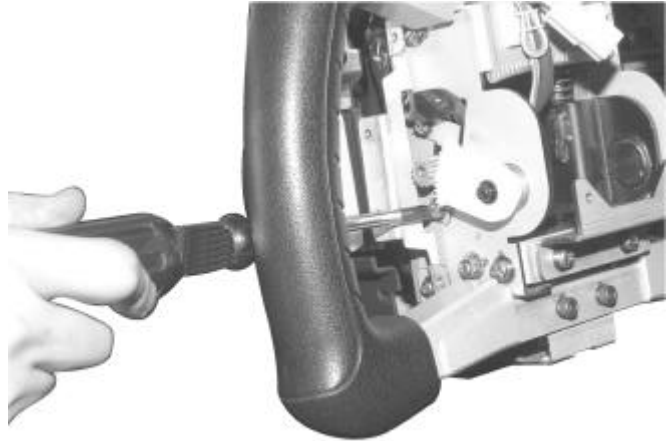

- Engage and secure the gear at such an angle that the D-cut side of the VR axle is horizontal and facing downward when the steering unit is not tilted.
- Manipulate the steering unit and make sure the gear is turning smoothly.
- Repeat the above steps in reverse to replace the front and rear steering covers. Take care not to pinch the wires or overtighten screws.  
Note that the screws used to secure the left and right sides of the front steering cover have different dimensions from the others. Check the screw sizes before installing them.
- Adjust the variable resistor settings on the Volume Settings screen (see 5.2.10.7.)
- Check to make sure the "STEERING Y" value on the Input Test screen is within the range 78H+/-8H.

#### 3.9.2.1.2.Replacement Procedure

- Perform steps 1 through 7 under "Adjustment Procedure" to detach the front and rear steering covers.
- Unplug the Y-axis VR wire connectors and unfasten the harness lug holding the wiring in place.



3. Remove the 2 screws holding the variable resistor bracket in place and then remove the Y-axis VR, bracket and all.

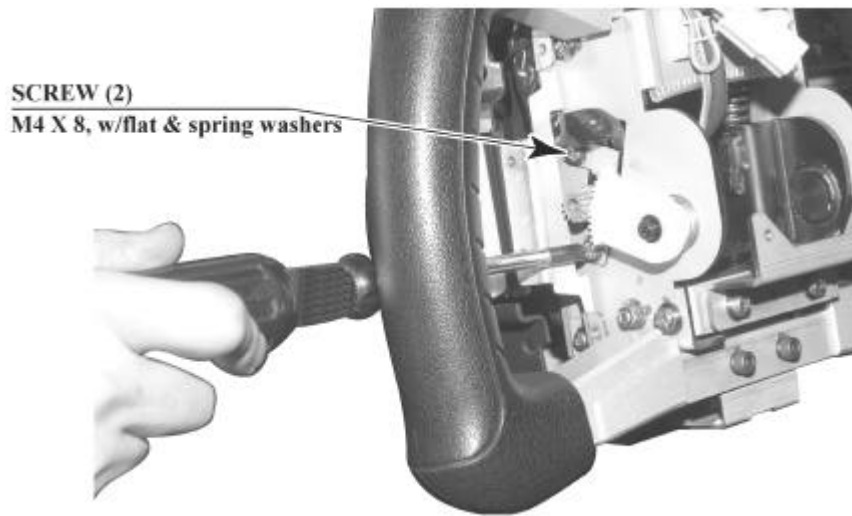

4. Loosen the 2 hexagon socket screws holding the gear in place and disengage the gear from the VR axle.

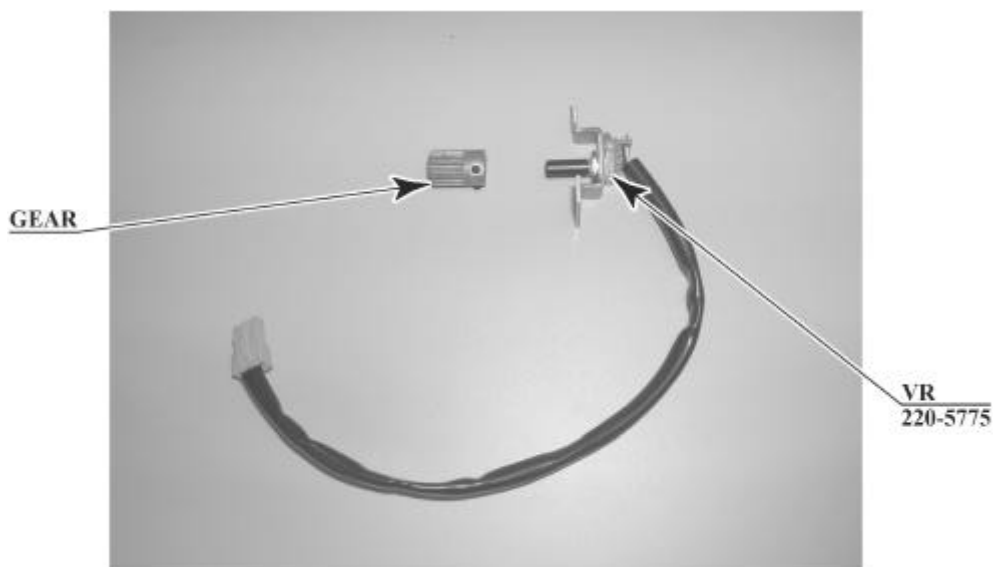
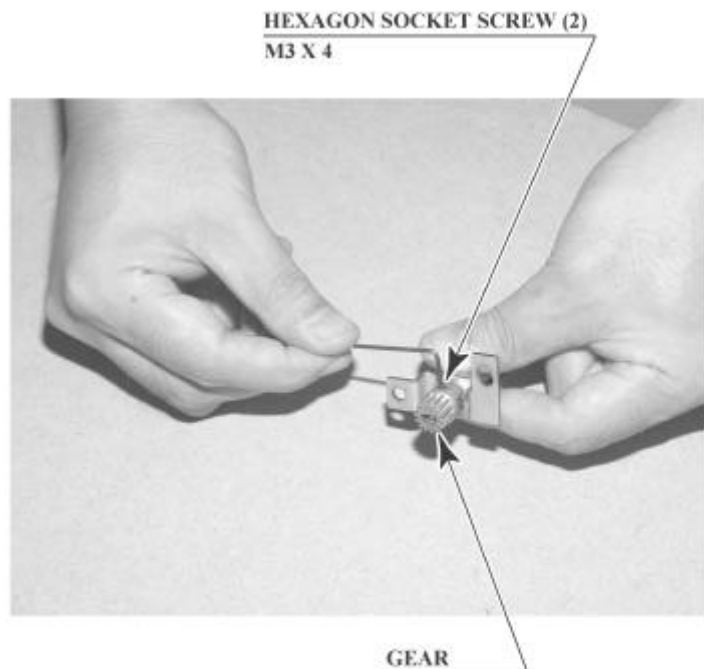



5. The wires connected to the old VR can be reused for the new VR. Use the soldering iron to melt the welds and remove the wires from the VR.

6. Solder the wires to the new VR. Check the wiring diagram to make sure there are no mistakes in the wiring.

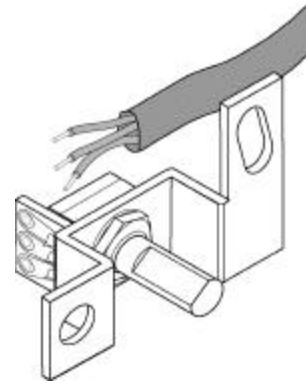

7. Attach the gear to the new VR.

8. Install the new Y-axis VR. Engage and secure the gear at such an angle that the D-cut side of the VR axle is level and facing downward when the steering unit is not being tilted.

9. Manipulate the steering unit make sure the gear is turning smoothly.

10. Plug in the wiring connectors and secure the wires with the harness lug.

11. Repeat the above steps in reverse to replace the front and rear steering covers. Take care not to pinch the wires or overtighten screws.

Note that the screws used to secure the left and right sides of the front steering cover have different dimensions from the others. Check the screw sizes before installing them.

12. Adjust the variable resistor settings on the Volume Settings screen. (see .)

13. Check to make sure the "STEERING Y" value on the Input Test screen is within the range 78H+/- 8H.

### 3.9.2.2.Replacing The Microswitches

Movement in the steering unit's paddle levers is detected by 2 microswitches on the bottom of the interior of the steering cover. Follow the steps listed below to replace or adjust the position of these switches.

Note that each of the 2 microswitches on the bottom of the steering unit is linked to the paddle on the OPPOSITE side in the "PADDLE LEFT/RIGHT" test on the Input Test screen; that is, the microswitch on the right controls the "PADDLE LEFT" value, and vice-versa. Check to make sure the switch being replaced or adjusted is the correct one.

The following tools and instruments are required for the following operations:

- 3mm diameter hexagonal screwdriver or wrench
- M4-size Phillips screwdriver
- M3-size Phillips screwdriver
- Nippers
- Cutters
- Soldering iron
- Industrial dryer

#### 3.9.2.2.1.Adjustment Procedure

1. Perform steps 1 through 7 for adjusting the Y-axis VR to remove the front steering cover and detach the rear steering cover (see 3.9.2.1).
2. Loosen the 2 screws securing the SW ADJUST plate on which the microswitch to be adjusted is installed, and then move the SW ADJUST plate to adjust it. Do not loosen the screws on the side the microswitch is installed on.

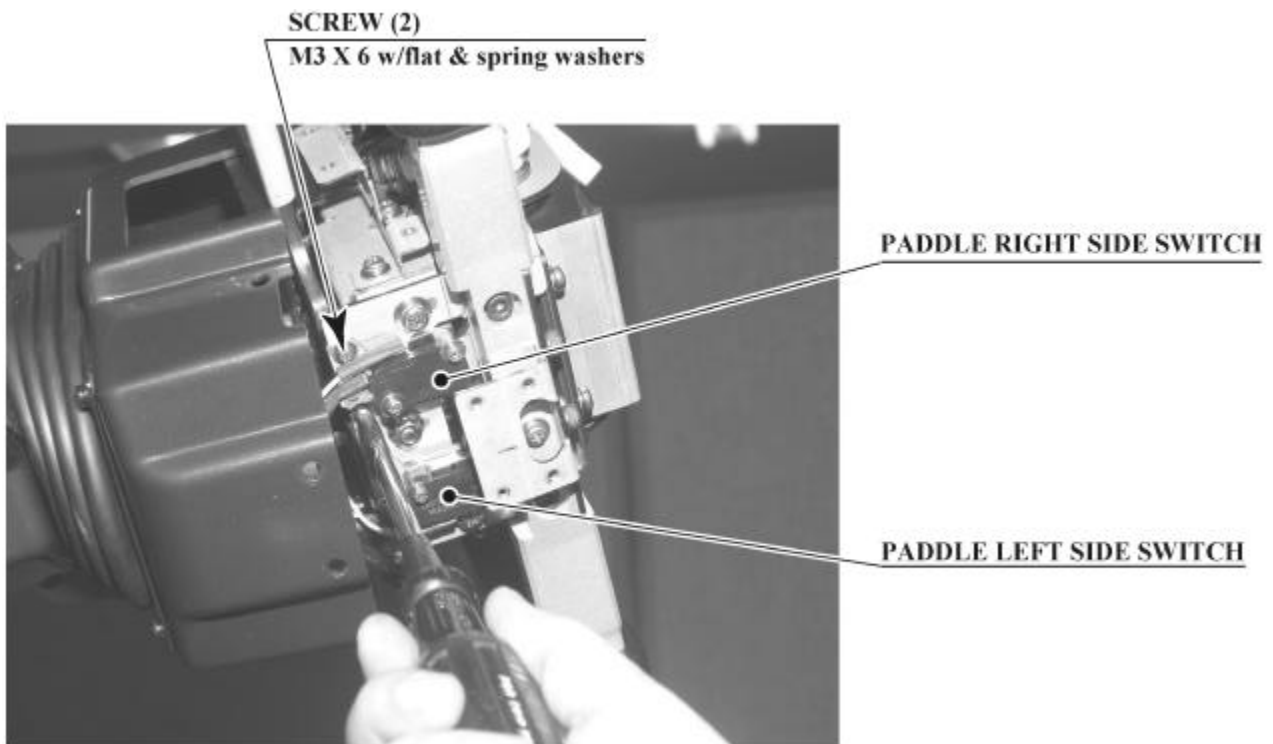

3. Adjust the switch so that the roller on its actuator terminal touches the pin that interlocks with the paddle lever when the lever is not being manipulated.
4. Tighten the 2 screws.
5. Manipulate the paddle lever to make sure the microswitches are turning on and off properly. Listen for a clicking sound. Also, make sure that the switch does not adhere to the actuator itself when turned on.
6. Replace the front and rear steering covers. Take care not to pinch the wires or over tight en the screws.  
Note that the screws used to secure the left and right sides of the front steering cover have different dimensions from the others. Check the dimensions of the screws before installing them.
7. On the Input Test screen, check to make sure that the microswitches turn on and off consistently when the paddle levers are manipulated (see 5.2.10.2).

#### 3.9.2.2.2.Replacement Procedure

1. Remove the front steering cover and detach the rear steering cover (see 3.9.2.1).

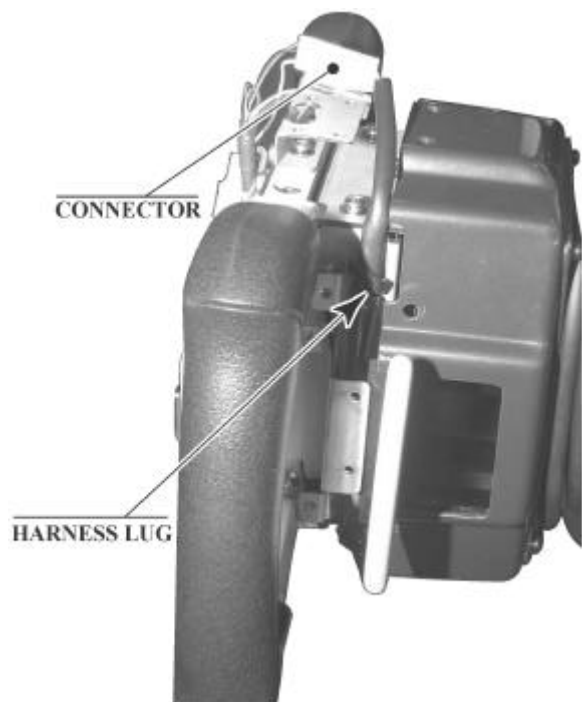

2. Unplug the wire connectors from the microswitch and unfasten the harness lug holding the wires in place

3. Remove the 2 screws holding the SW ADJUST plate in place and then remove the microswitch together with the SW ADJUST plate.

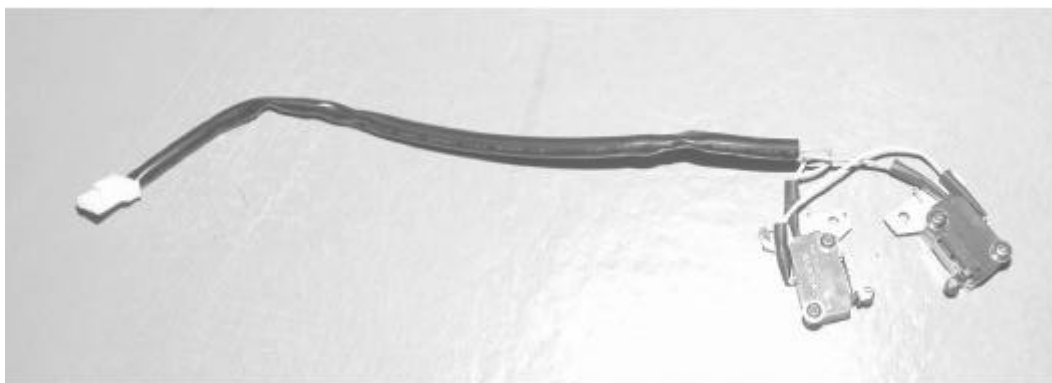

4. Remove the 2 screws securing the microswitch to be replaced and then remove the SW ADJUST plate and the transparent insulation sheet.

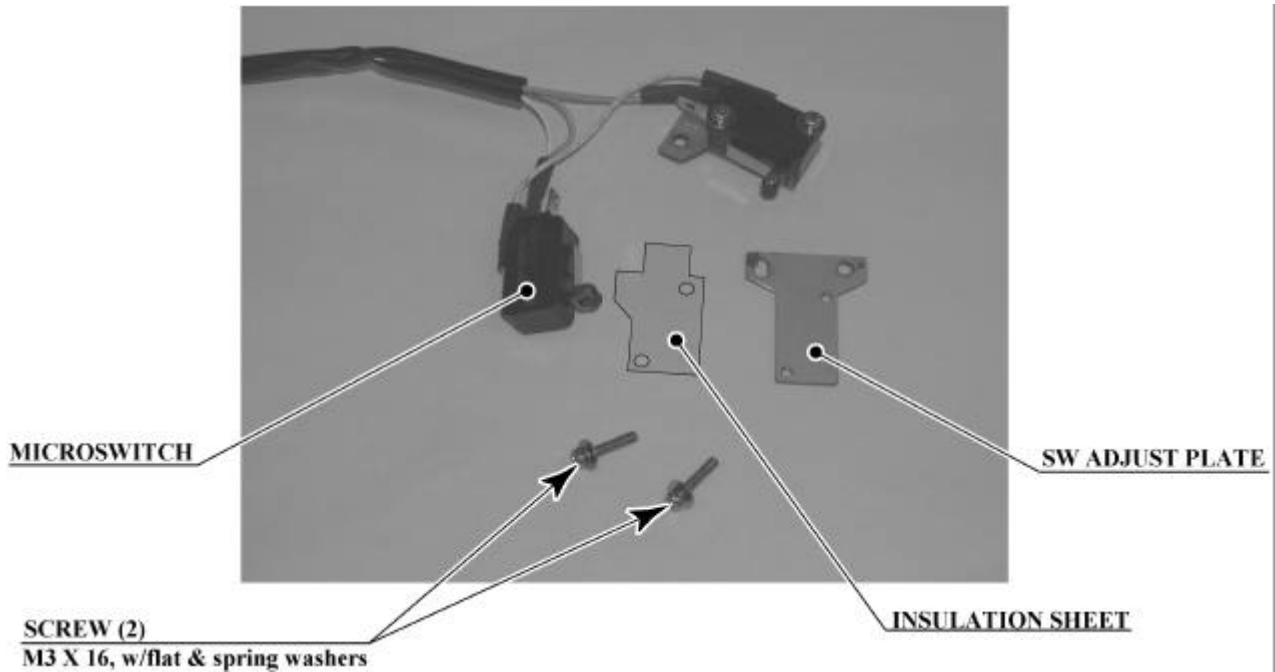

5. The wires connected to the old microswitch can be reused for the new microswitch. Remove the heat contraction tube covering the soldered areas, use the soldering iron to melt the solder, and remove the wires from the microswitch.
6. Solder the wires to the new microswitch. Check the wiring diagram to make sure there are no mistakes in the wiring. In addition, use a heat contraction tube or other protection to prevent short-circuiting.
7. Attach the SW ADJUST plate and the insulation sheet to the new microswitch and secure them with 2 screws. Be sure to insert the insulation sheet between the switch and the plate.
8. Install the SW ADJUST plate with the new microswitch in the bottom of the steering unit. Adjust the position of the plate so that the roller on the microswitch's actuator terminal touches the pin that interlocks with the paddle lever when the lever is not being manipulated, and secure it with 2 screws.
9. Connect the wire connectors and secure the wires with a harness lug.
10. Manipulate the paddle lever to make sure the microswitches are turning on and off properly. Listen for a clicking sound. Also, make sure that the switch does not adhere to the actuator itself when turned on.
11. Replace the front and rear steering covers. Take care not to pinch the wires or over tight en the screws.  
Note that the screws used to secure the left and right sides of the front steering cover have different dimensions from the others. Check the dimensions of the screws before installing them.
12. On the Input Test screen, check to make sure that the microswitches turn on and off consistently when the paddle levers are manipulated (see 5.2.10.2).

### 3.9.2.3. Greasing



- Be sure to use the designated type of grease. If a non-designated type grease is used, components may break.
- Do not apply grease to any part of the machine other than those parts specifically indicated. Doing so may result in malfunctioning and/or deterioration of parts.
- The period for greasing specified herein is a standard. Apply greasing to the specified portions as occasion arises.

Use spray grease once every three months to grease up the gear mesh portion of the constituent parts. Use "Grease Mate" (part number 090-0066) for the spray grease.

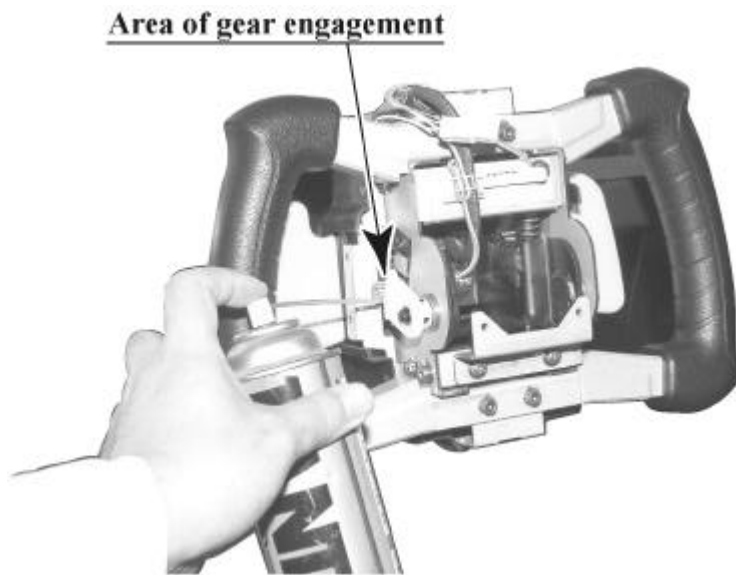

### 3.9.3. Card Reader/Writer Unit



- Take care to work on the machine with the power turned off. In the powered state, the machine may operate suddenly and can cause fingers to be pinched or cut.

#### 3.9.3.1. Setting Dedicated Cards



- Be sure to use dedicated cards available for this product. Use of ones other than such dedicated cards may cause a malfunction or failure of the machine.
- Be sure to set the specified number of card in the specified orientation by using the specified procedure. Wrong setting of the cards may cause the machine to fail.
- This machine allows you to set up to 100 cards at a time. You must not set over 101 cards at a time. If you do so, a trouble such as card jamming may occur.
- Set virgin cards taken out from a container that was unpacked immediately before use.
- Use of any deformed or deteriorated card may cause a trouble.
- Do not include a corrugated, bent, or used card in the card deck.

When the unit is out of cards, a message will be displayed at the upper right of the screen during advertisements. Follow the instructions below to restock the system with cards. Cards may be stocked when the unit is on or off.

After restocking the system with cards, the message displayed after the "SEGA" logo will be updated. Gameplay can be resumed without waiting for the updated message.

#### Remove the truss screw

- Unlock and open the cover to find the card reader/writer.  
The dispenser on which you should place the cards is located at the rear of the reader/writer.
- From the card reader/writer, take out the dispenser upward in a straight line.



C) Remove the cover from the back of the dispenser.

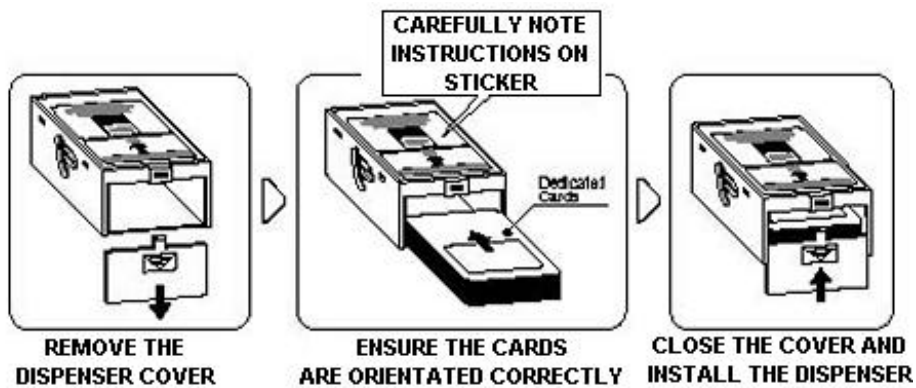

D) Place the cards into the dispenser according to the instructions on the sticker attached to the dispenser. Refer to the diagram shown on the sticker and insert the cards. Be careful not to insert the cards in the wrong direction or with the wrong side facing up.

The Dispenser can only hold 100 cards. Do not attempt to insert more than 100 cards, as too many cards may cause the Dispenser to jam or result in other problems.

Insert magnetic cards into the Dispenser in complete packs of 100 or after carefully counting the number of cards (not to exceed 100).

**LOAD CARDS THE CORRECT WAY AROUND**

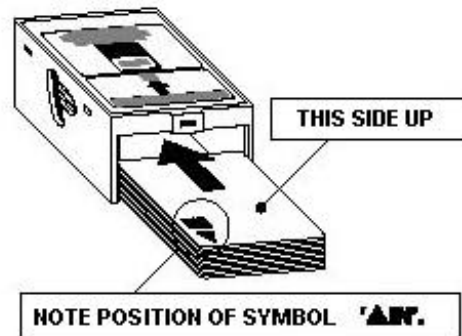

E) Reinstall the cover to the dispenser.

F) Insert the dispenser into the card reader/writer. The dispenser can be inserted only in the predetermined orientation.

G) Close and lock the cover.

H) Secure with the truss screw

### 3.9.3.2.Head Cleaning



- The unit enters Head Cleaning Mode when any of the following conditions are met:
- At power-up if the Card Reader/Writer has operated 100 times or more
- At power-up if the date has been updated
- At boot time after performing Backup Data Clear
- Once the unit enters Head Cleaning Mode, follow the on-screen instructions and perform Head Cleaning. The unit will not exit Cleaning Mode (i.e. games may not be played) until head cleaning is complete.
- Always use the designated Cleaning Card. Using anything other than the designated card or carrying out any other procedure other than the one outlined in the manual may cause faulty printing, faulty operation and/or unit failure.
- Cleaning Cards may only be used once. Dispose of them after use.
- Cleaning Cards should be used immediately after removal from the package. Cleaning Cards will not clean effectively if dried out.
- Perform head cleaning only when there are cards in the Card Reader/Writer Dispenser. If the Dispenser is empty, the part that secures the cards inside the Dispenser may touch the rotating part of the Card Reader/Writer and cause noise.
- Always remember to remove the Cleaning Card after completing head cleaning.
- After head cleaning, wait for the "SEGA LOGO" to be displayed at least twice before resuming gameplay.

This machine records the number of times the Card Reader/Writer is used. The Card Reader/Writer writes data to and reads data from cards. Each write and read is counted, so the Card Reader/Writer usage count will not be the same as the number of times the game is played. Once head cleaning of the Card Reader/Writer is complete, the unit will exit this mode. Follow the on-screen instructions to carry out cleaning.

**CLEANING CARD**



PLEASE INSERT CLEANING CARD

Insert the Cleaning Card into the card slot.

NOW CLEANING...

Indicates that the unit is undergoing cleaning. Wait for cleaning to be completed.

The unit exits to normal mode after cleaning is complete. Do not forget to remove the Cleaning Card. Wait for the "SEGA LOGO" to be displayed at least twice before resuming gameplay after cleaning.

The Card Reader/Writer usage count described above is reset when cleaning is performed. Manual head cleaning may also be performed from Test Mode. Refer to Test Mode Section 5.2.10.6 for more details.



### 3.9.3.3. Clearing Card Jams



**IMPORTANT!**

When attempting to perform this operation without powering down so that gameplay can be restored, exercise extreme caution. Machine parts may move unexpectedly when the power is ON. This may result in fingers being caught or severed and other injuries.

Verify the Stay Lock on the top cover before attempting this procedure. If the top cover closes during the procedure, it may result in serious injury.

If a problem, such as card jamming, occurs on the card reader/writer it will be reported on the screen. Play cannot proceed unless this problem is resolved. Identify the nature of the problem before any action is taken.

If repeated attempts continue to generate errors, follow the instructions below to remove the card. Removing the card may force the game to shut down. If the game shuts down, existing customer game data will not be saved.

- A) Remove the truss screw.
- B) Unlock and open the cover.
- C) Unlock the hatch by drawing the green shaft attached to the top cover on the card reader/writer. While drawing the shaft, open the cover up.
- D) Remove the card jammed in the card reader/writer.

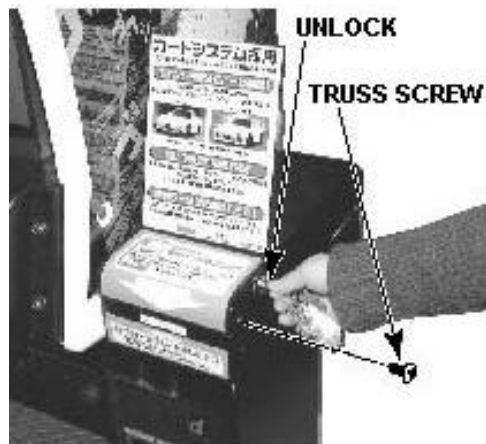

- E) While drawing the shaft, close the cover. With the top cover closed, release the green shaft. Check that the top cover has been locked securely.

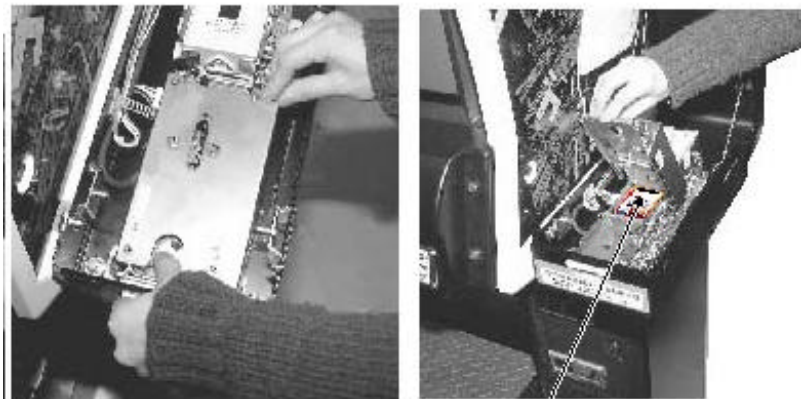

- E) Close and lock the cover.
- F) Secure with the truss screw.

### 3.9.4. Accelerator & Brake



- Only Qualified Service Personnel must carry out maintenance. Ensure that the mains power is switched OFF and disconnected before attempting any work.

In the TEST MODE, if the brake or accelerator V.R. variations are not within the allowable limit, the V.R. installation position requires adjustment or the V.R. needs replacement. Also be sure to apply grease to all moving parts every 3 months.

#### 3.9.4.1. Removing the Accelerator & Brake.

**HEXAGON BOLT, BLACK (4)  
M8 x20 & WASHERS**

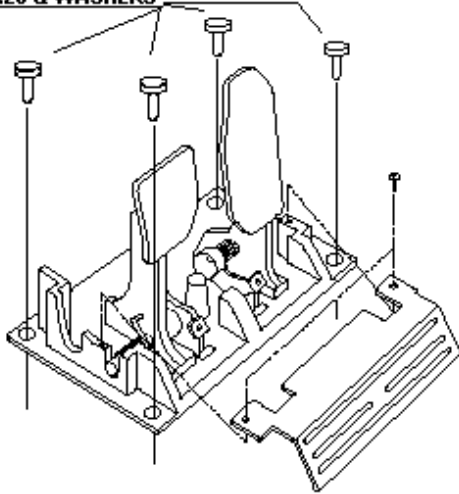

1. Turn the POWER switch OFF
2. Remove a total of 4 screws securing the covers over the ACCELERATOR & BRAKE
3. Fine adjustment of the V.R. values is accomplished with just these covers removed.
4. Coarse adjustment requires the ACCELERATOR & BRAKE mounting bolts to be removed. If this is necessary, remove the bolts from the unit, but do not remove the unit from the machine. Take extreme care when operating the unit in this condition as damage to other components can occur.

### 3.9.4.2.Adjusting the V.R.



- Never touch places other than those specified. Touching places other than those specified can cause electric shock and short circuit.

- After the replacement or adjustment of the V.R. be sure to set the values in the INPUT TEST.

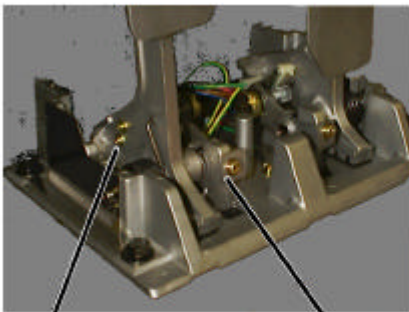

COARSE ADJUST SCREWS

FINE ADJUST SCREW

1. Remove the cover panels as detailed above.
2. Fine Adjustment - By using a screwdriver loosen the 2 machine screws that secure the V.R. arm. Move the V.R. arm to adjust the V.R. value within the relaxed range.
3. Coarse Adjustment - Remove the four hexagon bolts detailed above and remove the side covers of the Accelerator & Brake.
4. Loosen the two machine screws holding the V.R. rack
5. Move the V.R. rack away so as to disengage the V.R.
6. Gently rotate the V.R. until its value is within the range of the centring position.
7. Mesh the gears together. Make sure that a correct amount of backlash is maintained.
8. If the V.R. value is still not correct make fine adjustments as detailed above.

The required values are:

GAS PEDAL:	Under 30H	⇒	Over C0H
BRAKE PEDAL:	Under 30H (THE PEDAL RELEASED)	⇒	Over C0H (THE PEDAL PRESSED)

### 3.9.4.3.Replacing the V.R.

1. Loosen and withdraw the V.R. rack as detailed above.
2. Using a hexagon key loosen the two grub screws holding the V.R. gear onto the V.R.
3. Remove the V.R. gear
4. Using a spanner remove the nut holding the V.R. in position.
5. Gently remove the V.R. and its wire harness.
6. Refit is the reverse of removal.
7. When complete you must readjust the V.R. in accordance with the paragraph above.

### 3.9.4.4.Greasing



- Be sure to use a good quality, synthetic lubricant. Using a mineral-based lubricant will cause damage to the plastic parts.
- Do not apply lubricant to parts other than those specified. Doing so may cause damage or deterioration of parts.

Apply lubricant to gear mesh portions once every 3 months.

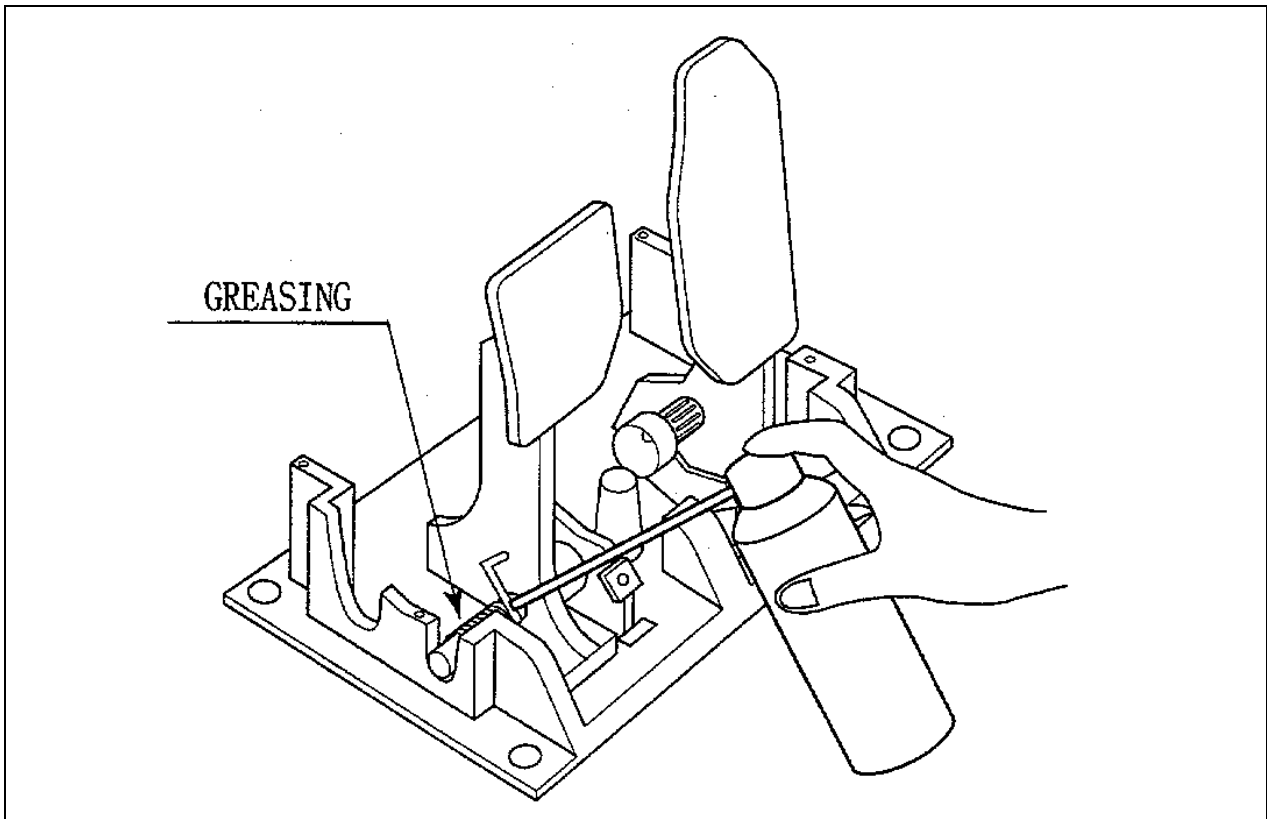

### 3.10. Replacement Of Fluorescent Lamp And Other Lamps



- Never touch places other than those specified. Touching places other than those specified can cause electric shock and short circuit. Disconnect the machine from the supply before attempting the replacement of any lamp.

- Prepare a secure step when working on the upper parts of the machine.

- Only QUALIFIED SERVICE PERSONNEL should replace lamps.

#### 3.10.1. Fluorescent Lamp Replacement

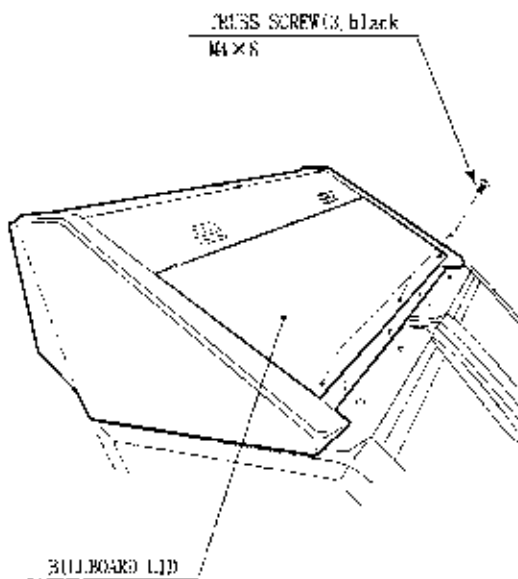

1. Turn the POWER switch OFF.
2. Take out the 3 screws and open the Billboard lid.
3. Remove the end caps from the fluorescent tube.
4. Pull the tube out of the clips with a twisting action.

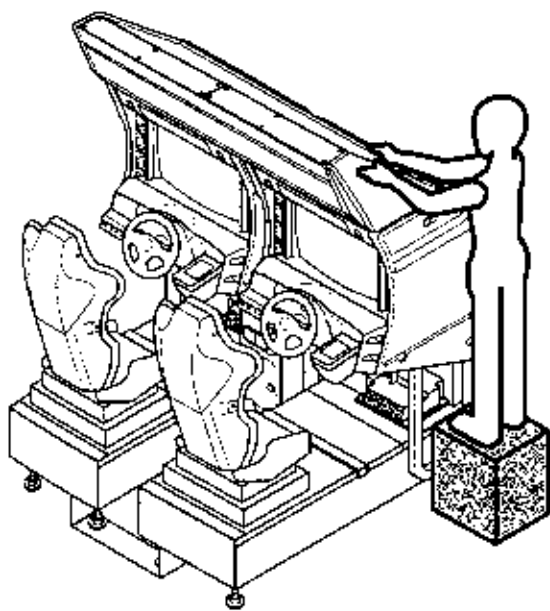

When performing work,  
be sure to use a step.

FLUORESCENT LAMP 40W

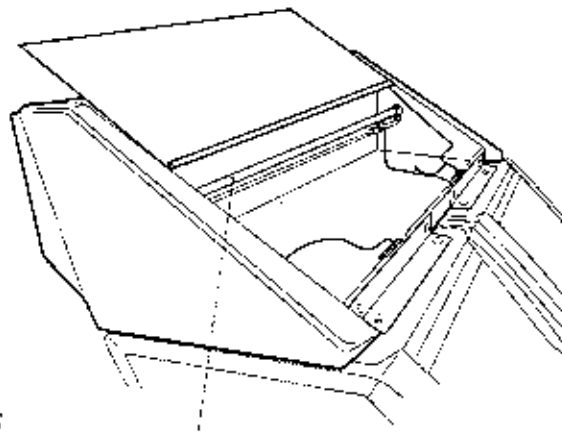

### **3.11. *Cleaning The Cabinet Surfaces***

When the cabinet surfaces are badly soiled, remove stains with a soft cloth dipped in water or diluted (with water) chemical detergent and squeezed dry. To avoid damaging surface finish, do not use such solvents as thinner, benzine, etc. other than ethyl alcohol, or abrasives, bleaching agent and chemical dustcloth.

### **3.12. *Seat (Greasing To Seat Rail Portion)***

Move the Seat to the rearmost position and apply spray greasing to the portion shown at the right once every 3 months by using NOK KLUBER L60 or GREASE MATE SEGA PART No. 090-0066.

After greasing, move the Seat a few times forward and backward so as to allow the grease to be applied all over uniformly. Be sure to wipe grease which attaches to the surfaces of the PROTECT RUBBER on the Seat Rail, or any excess grease.

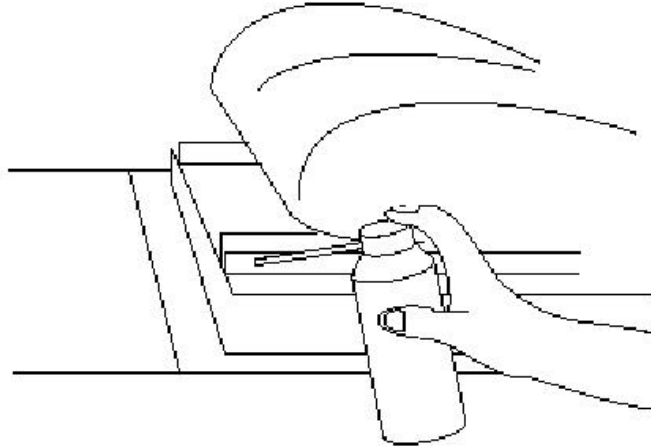

### 3.13. Troubleshooting



- Only QUALIFIED SERVICE PERSONNEL should carry out these procedures.

#### 3.13.1. Card Reader/Writer

If this machine detects an error during the operation of the Card Reader/Writer, it will display the error messages listed below. Perform the appropriate maintenance based on the content of the error message displayed.

Should an error occur, do not attempt to open the top cover of the Card Reader/Writer. The unit will attempt to save the data to the customer's card and restore the game if the top cover is closed and the RESTORE command (hold down the Start button + Change View button for a short time) is used. However, attempting to use the RESTORE command after the top cover has been opened may force the game to shut down and not save data to the card.

When the game shuts down or the unit is reset, the data on the customer's card is not saved. In order to save customer data, perform the proper maintenance carefully.

ERROR DISPLAY	CAUSE	COUNTERMEASURES
Error occurred while reading card. Card will be ejected without saving data. Please press the Start and Change View buttons.	This message is displayed after several failed attempts to save data to the card at the end of the game.	Press the Start button and Change View button at the same time to eject the card and end the game.
Error occurred while saving data. Please notify a store attendant. Please press the Start and Change View buttons.	This message is displayed after several failed attempts to print at the end of the game.	Leave the card in place and press the Start button and Change View button at the same time to retry the save operation. Remove the card and press the Start button and Change View button at the same time to restore or end the game. If this error occurs several times, use Test Mode to perform manual cleaning. (See Cleaning Section 3.9.3.2)
Printing error. Card will be ejected without printing or saving data. Please press the Start and Change View buttons.	This message is displayed after several failed attempts to read the card at the end of the game.	Press the Start button and Change View button at the same time to eject the card and end the game.
A shutter error has occurred. Please remove any cards present in card insertion slot. Please press the Start and Change View buttons.	This message is displayed when the shutter is forced open or if the unit detects a problem with the shutter.  This message is displayed when the unit is unable to open/close the shutter.	Correct the problem, then press the Start button and Change View button at the same time to restore the game. Circumstance may force the game to shut down. Correct the problem, then press the Start button and Change View button at the same time to restore the game.
This card cannot be used. Card will be ejected without saving data. Please press the Start and Change View buttons.	This message is displayed when the card in the Card Reader/Writer is not a proper player card at the end of the game.	Press the Start button and Change View button at the same time to eject the card and end the game.
Card jam. Ejecting card. Please press the Start and Change View buttons.	This message is displayed when various operations fail because of dirty rollers or heads.	Press the Start button and Change View button at the same time to eject the card and restore the game. If this error occurs several times, use Test Mode to perform manual cleaning. (See Section 3.9.3.2)

Continued from previous page

ERROR DISPLAY	CAUSE	COUNTERMEASURES
There is a problem with the card reader/writer. Please notify a store attendant. Please turn off the power and start again.	This message is displayed when there is a problem with the Card Reader/Writer and it sends improper signals.	Verify there are no problems with the shutter and that the top cover is closed and then restart the unit.
The card reader/writer is not responding. Please notify a store attendant. Check the card reader/writer is connected properly, turn off the power and start again.	This message is displayed at power-up during advertisements when the Card Reader/Writer is not connected properly or when it is broken and unresponsive.	Verify that the Card Reader/Writer is connected properly and then restart the unit.
SCIF Error. Please notify a store attendant. Check that the card reader/writer is connected properly, turn off the power and start again.	This message is displayed when a communication error occurs between the Card Reader/Writer and the game board.	Verify that the Card Reader/Writer is connected properly and then restart the unit. If this error occurs several times, check the immediate area for sources of possible interference.
Card jam. Remove the card and press the Start and Change View buttons. If the card cannot be removed, please notify a store attendant.	<p>This message is displayed when various operations fail because of dirty rollers or heads.</p> <p>This message is displayed when a card jam is suspected when there should be no card in the Card.</p>	<p>Leave the card in place and press the Start button and Change View button to retry the operation.</p> <p>Remove the card and press the Start button and Change View button at the same time to restore or end the game (refer to 3.9.2).</p> <p>If this error occurs several times, use Test Mode to perform manual cleaning.</p> <p>Press the Start button and Change View button at the same time after removing the card or correcting the problem to restore the game.</p>



The following error messages are displayed when problems are detected during unit power-up (during initialization of the Card Reader/Writer). Perform the appropriate maintenance based on the content of the error message displayed.

ERROR DISPLAY	CAUSE	COUNTER MEASURES
CARD R/W ERROR!	This message is displayed at power-up when the Card Reader/Writer is not connected properly or when it is broken and unresponsive.	Verify that the Card Reader/Writer is connected properly and then restart the unit. If broken, contact the company from whom the unit was purchased.
PLEASE INSERT CLEANING CARD.	This message is displayed when the conditions prompting an automatic Card Reader/Writer cleaning are met.	Perform the Card Reader/Writer cleaning. (See 3.9.3.2)
PLEASE WAIT	This message is displayed during network setup while the other unit is being initialized.	This message disappears once initialization of the other network game unit is complete.
CAN'T EJECT	This message is displayed at power-up when, after attempting to do so, the Card Reader/Writer is unable to eject a card for some reason.	Remove all cards from the Card Reader/Writer. (See 3.9.3.)
	This message is displayed at power-up when the shutter cannot be opened/closed properly.	Verify that there are no problems with the shutter and then restart the unit. If this error occurs several times, contact the company from whom the unit was purchased.

The following messages are displayed when there are limits to the Card Reader/Writer Operation Mode. The messages are displayed in the upper right of the screen during advertisements. The message content is updated after the "SEGA LOGO" is displayed.

If the message is not one displayed intentionally by the Operation Mode, perform the appropriate maintenance based on the content of the error message displayed.

ERROR DISPLAY	CAUSE	COUNTER MEASURES
The machine is currently unable to issue new cards. Please see a store attendant to have the machine restocked with cards.	The Card Reader/Writer Dispenser is empty (no cards).	Restock the Dispenser with cards. (See 3.9.3) If no cards are available, contact the company from whom the unit was purchased
Cards may not be used at this time.	Cards may not be used due to the Store Closing setting being activated.	If there is a mistake in the settings, use Test Mode to change the Store Closing setting. If the setting is correct, but not operating properly, check the internal clock settings on the game board (Refer to the Service Manual.)

### 3.13.2. Troubleshooting (When No Error Message Is Shown)



- In order to prevent electric shock and short circuit, be sure to turn power off before performing work.
- Be careful so as not to damage wirings. Damaged wiring can cause electric shock or short circuit.
- After removing the cause of the functioning of the Circuit Protector, reinstate the Circuit Protector. Depending on the cause of the functioning, using the Circuit Protector as is without removing the cause can cause generation of heat and fire hazard.
- In the event that a problem cannot be resolved by employing the procedures listed in this Manual, be sure to request service from the office shown on this Manual or the dealer from whom the product was originally purchased. Attempts to employ procedures other than those specified in this Manual can cause electrical shock, shorting, or fire.
- In the event of a problem that is not described here, be sure to contact the office shown on this Manual or the dealer from whom the product was originally purchased. Careless attempts at repair can result in electrical shock, shorting, or fire.

If a problem occurs, first check to make sure that the wiring connectors are properly connected.

PROBLEM	CAUSE	COUNTER MEASURES
When the main SW is turned ON, the machine is not activated.	The power is not ON.	Firmly insert the plug into the outlet.
	Incorrect power source/voltage.	Make sure that the power supply/voltage are correct.
	The fuse of the connect board was blown out due to momentary overcurrent.	After eliminating the cause of overload, replace the specified rating fuse.
Fluorescent lamp inside FL box doesn't light up.	Connector connection fault.	Check connector connections between the Cabinet and the FL box.
	Fluorescent lamp and Glow lamp need replacement.	Replace the fluorescent lamp and the glow lamp (See Section 3.10)

PROBLEM	CAUSE	COUNTER MEASURES
Sound is not emitted.	Sound volume adjustment is not correct.	Adjust the Switch Unit's sound adjustment volume.
	Faulty connections for various connectors.	Check the connections for the game board, amp, speakers and Volume connectors.
	Malfunctioning BD, Amp. and Speaker.	Perform SOUND TEST. (See 5.2.5)
Sounds are emitted and the lamps are lit, but the screen is black.	Faulty connections for the visual signal connector or the monitor power connector.	Check the connections for the monitor and game board connectors.
	Broken monitor.	Contact the company from whom the unit was purchased.
Irregular/uneven colors on the monitor screen.	Magnetization of the CRT.	Press the Degauss. switch on the VTS Assembly (See Section 5.1.1.)
Colors on the monitor screen are strange.	Faulty connection for the visual signal connector.	Check the visual signal connector connection and make sure it is secured properly.
	Screen adjustment is not appropriate.	Make adjustment appropriately. (See Monitor Manual)
The on-screen image sways and/or shrinks.	The power source and voltage are no correct.	Make sure that the power supply and voltage are correct.
Does not accept input from any switch or volume.	Faulty connector connections.	Check the connection for the I/O Board and Cabinet connector.
		Check the power for the I/O Board.
STEERING (Servomotor) response is incorrect.	Incomplete power on check.	Power on and verify that the power on check completes properly. (See 3.7.8 )
	Deviation of the volume value.	Adjust the volume value in the Test Mode.
	Volume gear engagement fault.	Adjust the engagement of the gear. (See Sections 3.9)
	Volume malfunctioning.	Replace the volume. (See 3.9.)
	Detached wires.	Check for faulty wire connections around moving parts. When replacing wires, secure them so that they do not touch any moving parts.

PROBLEM	CAUSE	COUNTER MEASURES
No response from Steering (Servomotor).	Failure of power-on checking procedure.	Reconnect the power and complete a power-on checking procedure. (See Section 3.7)
	Faulty connector connections.	Check the connections for the connectors between the Game Board and Servodriver and between the Servodriver and the Servomotor.
	Thermal element in the Servodriver is operating.	Occurs when the internal temperature reaches 70°C (158°F) and corrects automatically when the unit cools.
	Momentary overload caused a fuse on the Servodriver to blow.	Contact the company from whom the unit was purchased.
Steering (Servomotor) is weak in its force feedback.	Aging of the force feedback mechanism.	Reset in the Test Mode.
Unsatisfactory Accel and Brake operation.	Incorrect volume setting.	Adjust the volume value in the Test Mode. (See Section 5.)
	Faulty Volume attachment or adjust gear alignment.	Adjust the volume attachment and verify in Test Mode. (See Section 5.)
	Faulty connector connection.	Check the connections for the Accel and Brake connectors and the connectors between the Accel, Brake and Cabinet.
	Failure of the volume.	Replace the volume.
Start button and Change View button input does not work and they do not flash.	Faulty connector connections.	Check the connections for the connectors between the I/O Board, the Cabinet and the Control Panel and those inside the Control Panel.
Start button and Change View button input works, but they do not flash.	Unverified settings or operation.	The Start button only flashes when Free Play is set. Check the operation in Test Mode. (See Section 3.9)
	The lamp is burnt out.	Replace the lamp.
Failure of the network play.	Network play is wrongly set.	Reset correctly. (See Section 5)
	Communication cables are wrongly connected.	Reconnect the cables. (See Sections 3.7 and 5)
	Communication cables are disconnected.	
	Damage of communication cables.	Reconnect cables correctly. (See Section 5) Replace the cables. Contact the company from whom the unit was purchased.

### 3.14. Gameboard



- Turn off the mains power and remove the power cord before opening the machine.

- The GAME BOARD should not require any work to be carried out upon it. All settings and tests can be achieved without access to the GAME BOARD.
- All work to be carried out by QUALIFIED SERVICE PERSONNEL

#### 3.14.1. Removing The Board

To return the game board for servicing, take out the board using the following procedure.

1. Turn the main switch OFF.
2. Unlock the base and remove the 2 M6 bolts.
3. Tip the seat carefully backwards as shown. Be careful not to damage the seat back when resting it on the floor. Use a protective mat under the seat back to protect it on hard floors.
4. Disconnect all connectors from the game board, remove the four screws securing the game board to the wooden base, and lift it out. Do not attempt to service the game board. THERE ARE NO USER SERVICEABLE PARTS INSIDE! Return the game board to the Service Department inside the special packaging provided.

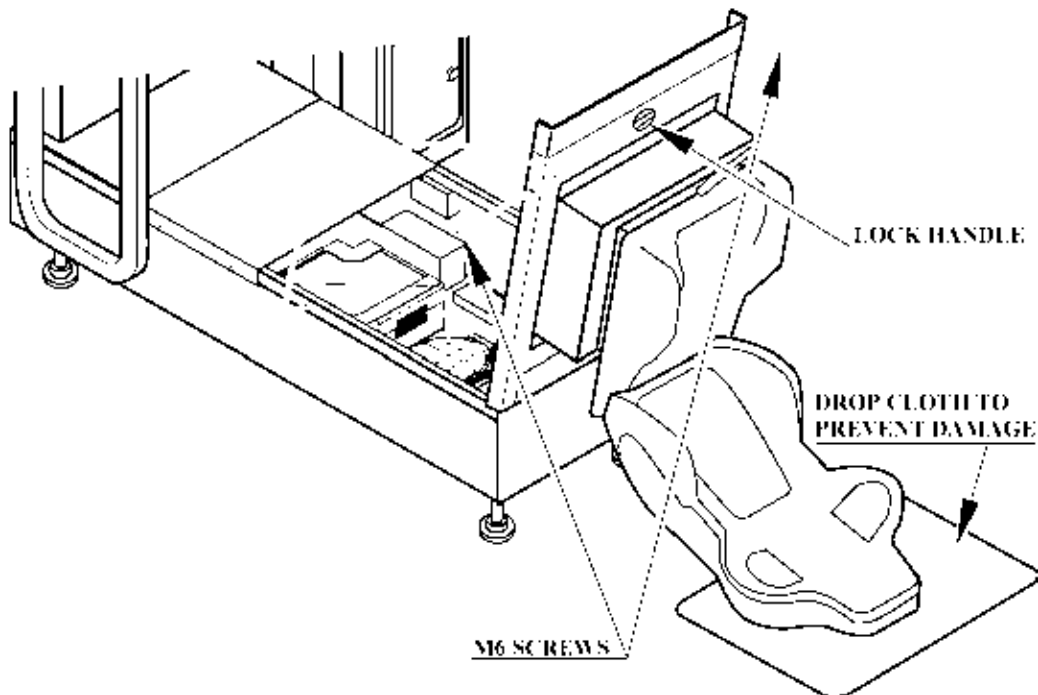

### 3.14.2. Removing The GD-ROM Drive

1. Turn the power off.
2. Remove 1 truss screw from each side of Base Lid R.
3. Unlock the base with the Master Key.
4. Turn the Lock Handle on Base Lid R to unlock the lid.
5. Lower the seat towards the backrest. Slowly lower the backrest until it touches the floor to prevent damage to the seat part. Put a drop cloth on the floor to prevent damaging the surface of the seat part.

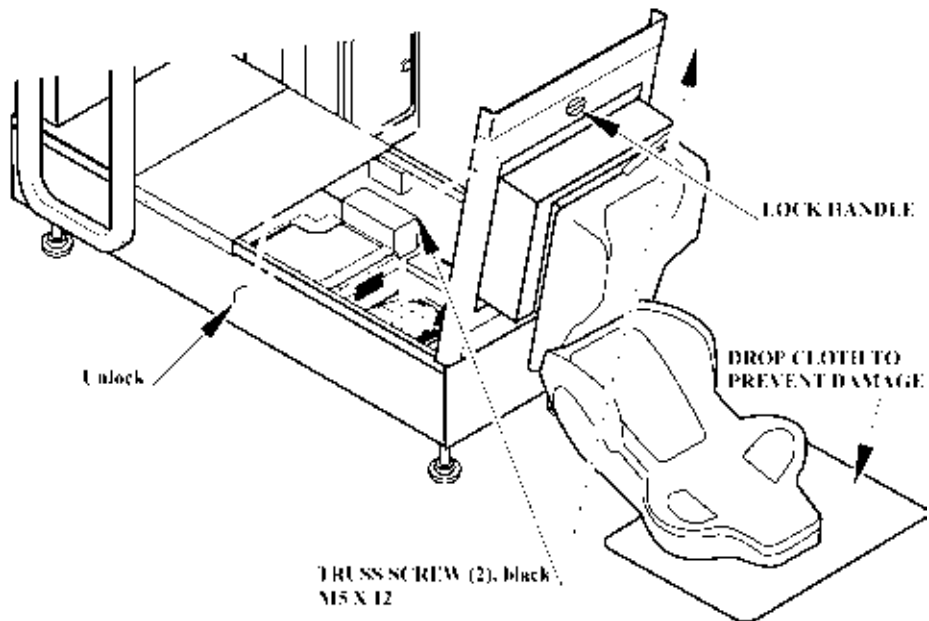

6. Remove the GD cable connector and the power cord connector from the GD-ROM drive.

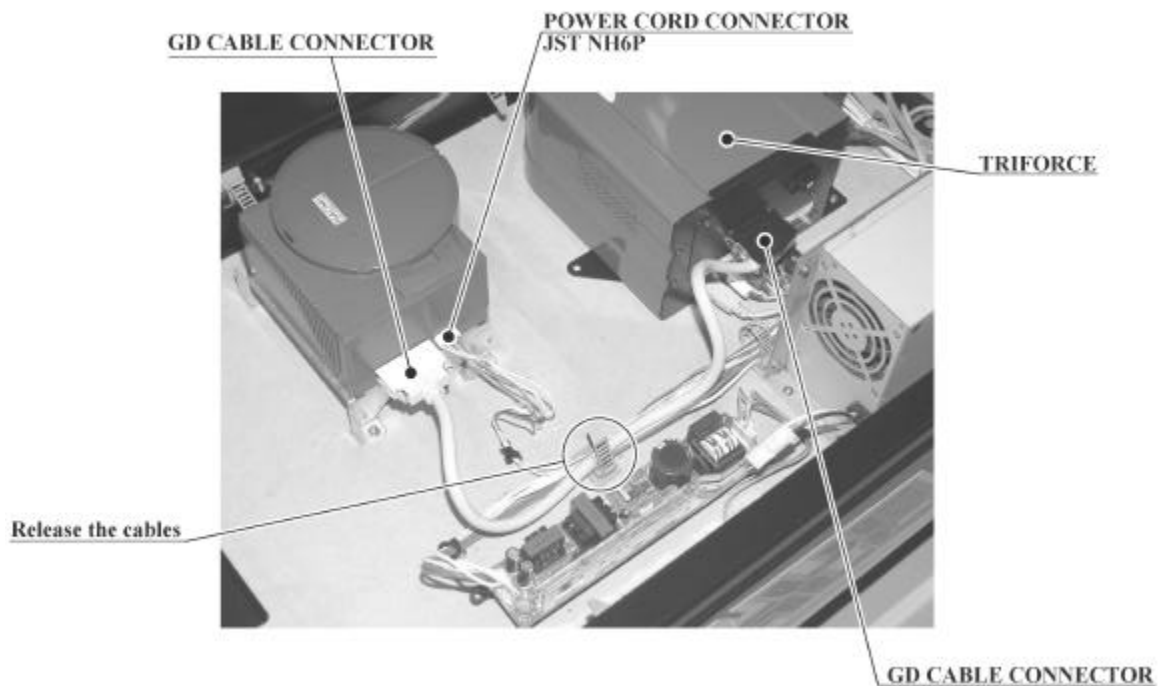

7. Remove the 4 screws to remove the GD-ROM drive.



**SCREW (3)**  
M4 X 16, w/flat & spring washers

### 3.14.3. Removing The Game Board (Triforce)



- When returning the game board for replacement or repair, make sure that the connectors are attached correctly. Incorrect connections can lead to accidents such as electric shock, short circuits, and/or fire.
- When plugging in connectors, pay close attention to the direction of the connection. The connectors are designed to be connected in a specific direction. Attempting to plug in a connector by applying excessive force may damage the connector or its terminal clasp, possibly resulting in electric shock, short circuits, and/or fire.

1. Follow the above described action 1 to 5.
2. Remove all the connectors from the TRIFORCE.
3. Remove the 3 screws that fix the Game Board.

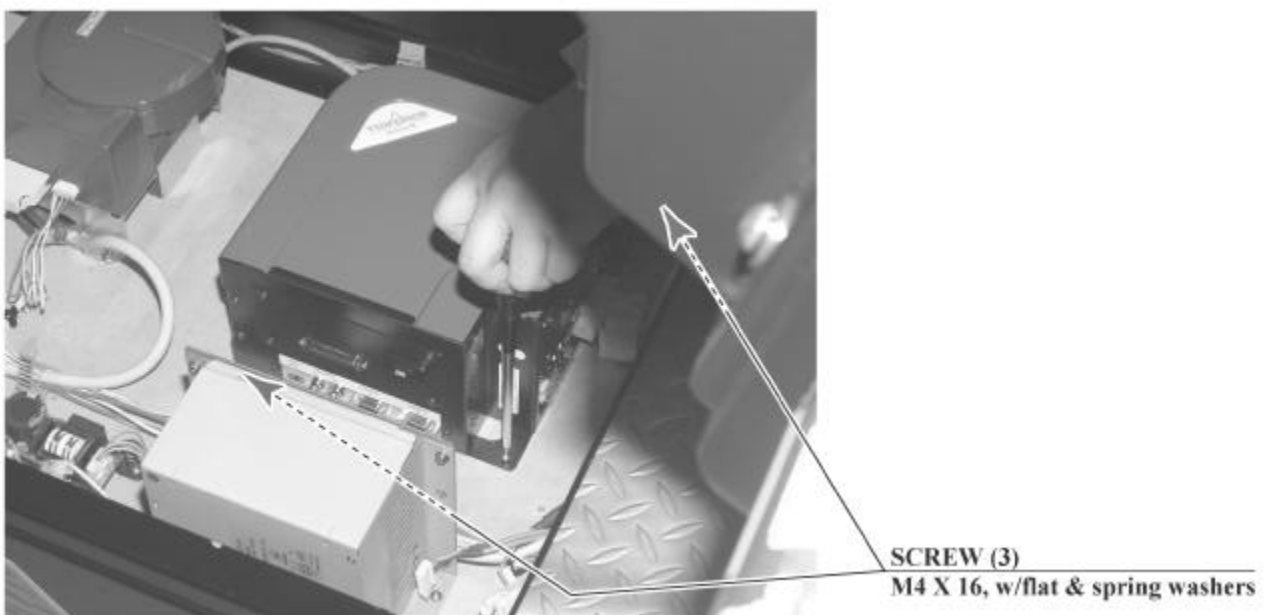
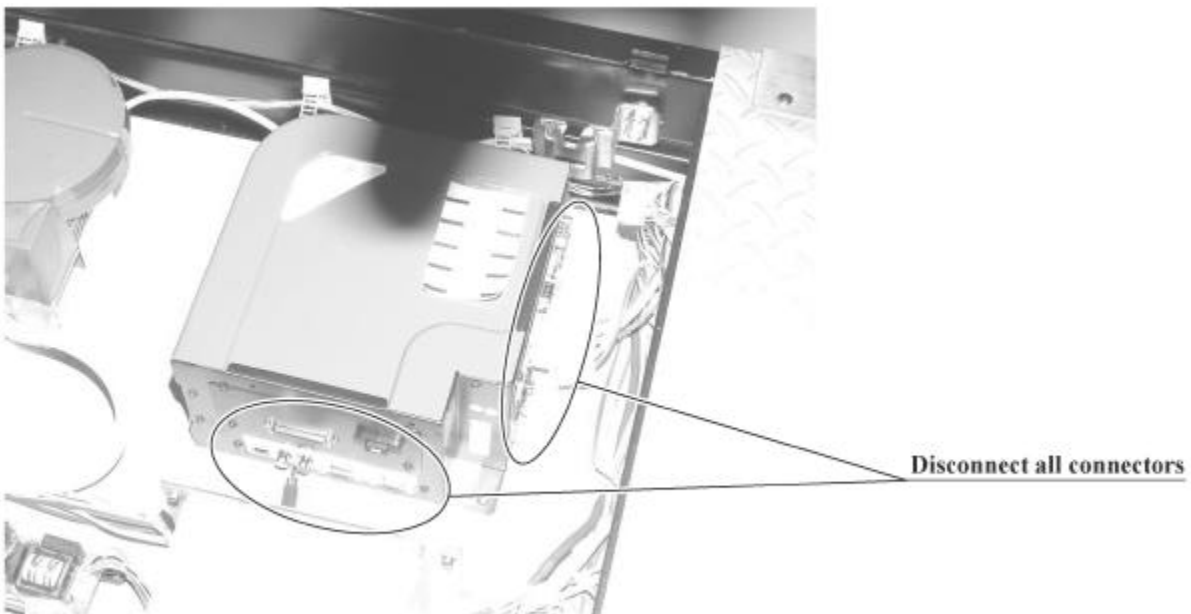



### 3.14.4. Composition Of The Game Board



- With the key chip installed, the TRIFORCE board becomes a proprietary game board for this product.

ASSY TRF FZR USA (842-02DD511U): USA  
ASSY TRF FZR EXP (842-02DD511E): OTHERS  
ASSY TRF FZR ASIA (842-04DD511E): ASIA

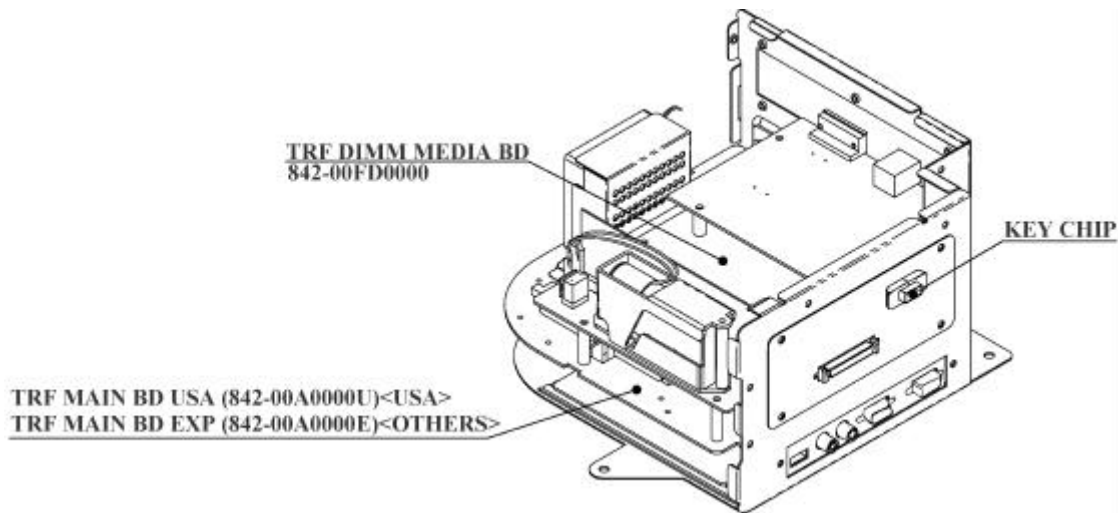

#### 3.14.4.1. DIP SW Setting

Use this product with the DIP SW settings shown in the figure below.

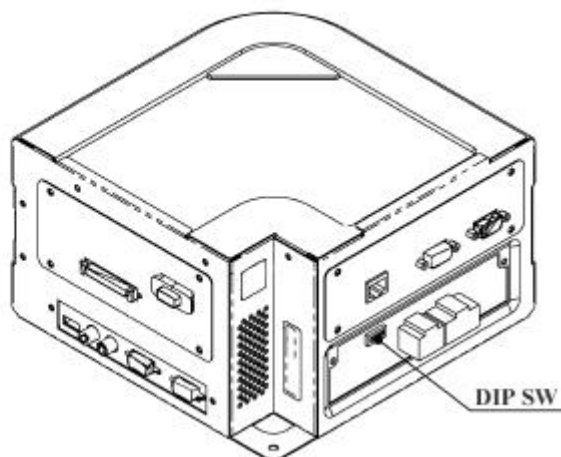
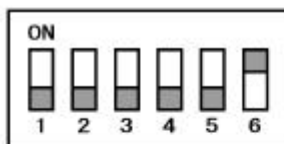

### 3.14.5.Replacing The Main Board Battery



- To prevent overheating, explosion, or fire:
  - Do not recharge, disassemble, heat, incinerate, or short the battery.
  - Do not allow the battery to come into direct contact with metallic objects or other batteries.
  - To preserve the battery, wrap it in tape or other insulating material.
- Follow local regulations when disposing of the battery.
- Improper disposal can damage the environment.



- To avoid risk of malfunction and damage:
  - Make sure the positive and negative ends are aligned correctly.
  - Use only batteries approved for use with this unit.



- If an error appears indicating that the battery power is very low within the first year of use, it is usually an indication of a problem or abnormality with something other than the battery. Be sure to inspect the board that the battery is connected to.

1. Remove the 5 screws holding the TRIFORCE and its cover in place.
2. Slide the cover off of the TRIFORCE, being careful of the hook that holds them together.

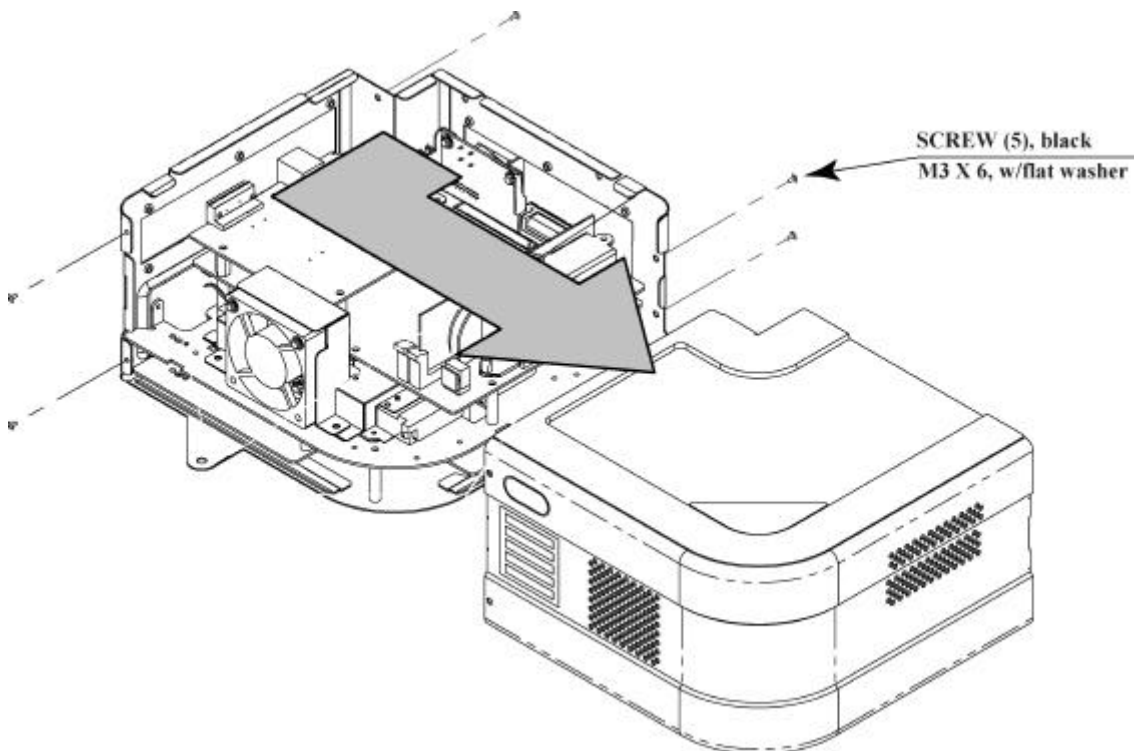

3. Gently remove the battery from the battery holder. The battery holder is located on the very bottom of the main board.
4. Insert the new battery (CR2032) so that the + terminal is pointing upward.

Removed batteries should be disposed of in accordance with relevant national laws and/or local regulations.

TRIFORCE MAIN BOARD BATTERY  
SEGA PART No.: 401-0065  
SEGA PART NAME: BATTERY CR2032 HITACHI

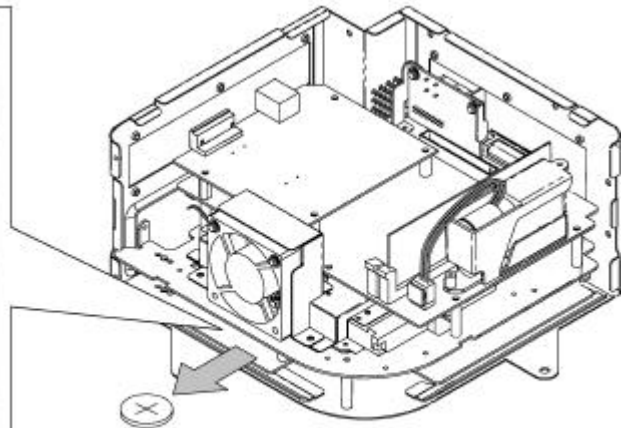
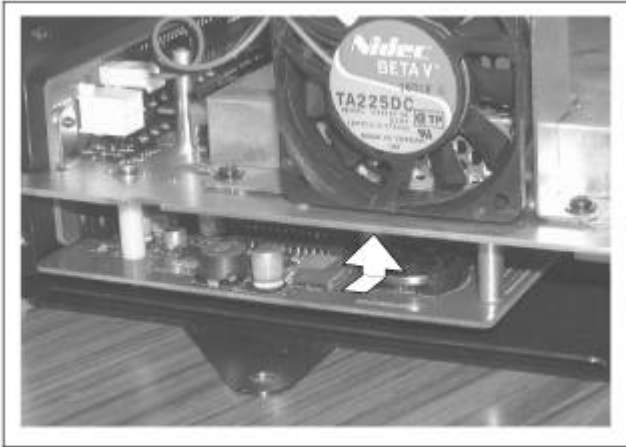

### 3.14.6.Replacing The DIMM Board Battery Pack

#### 3.14.6.1.Warnings And Restrictions Concerning The Battery Pack

Observe the following precautions when handling the DIMM board's battery pack. Sega cannot assume responsibility for any problems that arise from handling the battery pack in disregard of the guidelines set forth in the manual.



- Do not disassemble the battery pack and the batteries.
- If you should fail to observe this instruction, the internal wires and/or protective devices may be damaged; as a result the safety system may not function when discharging and recharging, eventually causing an over heating, fire and explosion. If you should disassemble the batteries, the generated gases may harm your throat and the negative plate may overheat and make a fire.
- Do not make an external short circuit of the battery pack and the batteries.
- If you should fail to observe this instruction, the batteries may overheat, make a fire, and explode.
- Do not fire the battery pack and the batteries.
- If you should fail to observe this instruction, the batteries may make a fire and explode.
- Do not leave the battery pack and the batteries nearby the heat source (fire or heater) or under the intense direct sunlight and flaming sun. If you should fail to observe this instruction, the batteries may reduce the service life and in the worst case may overheat, make a fire, and explode.
- Do not leave the battery pack and the batteries in water or seawater. Also do not apply water or seawater onto the battery pack and the batteries. If you should fail to observe this instruction, the internal wires and/or protective devices may be damaged; as a result the safety system may not function when discharging and re charging, eventually causing an overheating, fire and explosion. Also water may be electrolyzed into oxygen and hydrogen, and eventually the battery's sealed section may be corroded and the internal liquid may leak.
- Do not solder on the battery pack's terminals.
- If you should fail to observe this instruction, the armor may be heated and melted or the internal wires may be damaged, eventually causing an overheating, fire and explosion. Also, when the battery's temperature reaches to 100C or more, the battery may leak its internal liquid due to destruction of its plastic parts (gasket, separator, etc.), or may overheat, make a fire, or explode due to internal short-circuit.
- Do not insert or connect the battery in a reversal polarity.
- If you should fail to observe this instruction, the battery may be externally short-circuited and eventually overheat, make a fire, or explode, depending on the device you connect with.



- Do not tightly seal the battery pack when installing it onto an external device.
- Flammable gas is generated from the battery when its safety mechanism has functioned. If you should fail to observe the above-described instruction, sparks from motors, switches, etc. may cause the gas to fire. Therefore, install the battery pack so that the gas can be quickly released from the external device.
- Do not use the battery pack for the device/usage other than this game system.
- If you should fail to observe this instruction, the battery and/or the device may be damaged due to non-applicable specifications.
- Do not strike a nail in, hammer, step on, or apply any other forms of pressures and shocks on, the battery.
- If you should fail to observe this instruction, the battery may be deformed. As a result, the battery may burst at its sealed sections to leak the internal liquid, or may be short-circuited internally to overheat, make a fire, and explode.
- Do not use a battery charger because any battery charger is not usable for this battery pack.
- If you should fail to observe this instruction, the gas may be suddenly generated in the battery and eventually the battery may overheat, make a fire or explode.
- If the battery in use or in keeping shows an abnormal indication (deformation, change of colour, bursting of the armour cover, etc.), immediately stop using or keeping it. If it leaks and smells abnormally, immediately keep it away from fire and put it in a safety box.
- If the liquid leaks from the battery and gets in your eyes, do not rub your eyes but immediately wash them with clean water (city water etc.); and consult a medical doctor for a treatment. If you should fail to observe this instruction, the liquid may harm your eyes.
- The battery pack armour (a polyvinyl chloride tube) may be damaged or deformed by external force or heat. When transporting the battery pack or replacing it with a new one, therefore, be careful not to drop or excessively shock it. Do not continue to use any damaged or deformed battery pack. If you should fail to observe this instruction, the battery may overheat, make a fire, or explode.
- The battery pack contains a printed circuit board (PCB) for protective circuitry. It may be destroyed by the static electricity. When handling or servicing the battery pack, therefore, take preventive measures against the static electricity.
- If your battery pack has shown destruction of a protective circuitry PCB, do not continue to use it. If you should fail to observe this instruction, the battery may overheat, make a fire, or explode.
- When wiring the battery pack to a device, be careful not to apply excessive force onto the connectors and lead wires. The battery may overheat, make a fire, or explode if the connectors and lead wires are damaged.
- Do not do away with the used battery packs carelessly because they may contaminate the environment. Submit them to an industrial waste disposal plant.
- Be sure to dispose of the used battery pack in accordance with relevant national laws and/or local regulations.

If the GD-ROM drive appears to be taking too long to read the disc, the battery pack on the DIMM board may need replacing. The battery pack should last approximately 16 months under normal usage.

There is no recharging unit for the battery pack.

Follow the steps listed below to replace the battery pack.

1. Follow steps 1 and 2 in Section 3.14.5 to remove the cover.
2. Unplug the battery pack's connector.
3. Remove the single tapping screw and slide the battery holder cover to remove it.
4. Remove the battery pack.
5. Repeat the above steps in reverse to install the new battery pack.

The used battery pack is considered industrial waste.

As such, it should be disposed of in accordance with relevant national laws and/or local regulations.

#### DIMM BOARD BATTERY PACK

SEGA PART No.: 401-0081

SEGA PART NAME: BATTERY PACK CGR-B/246A

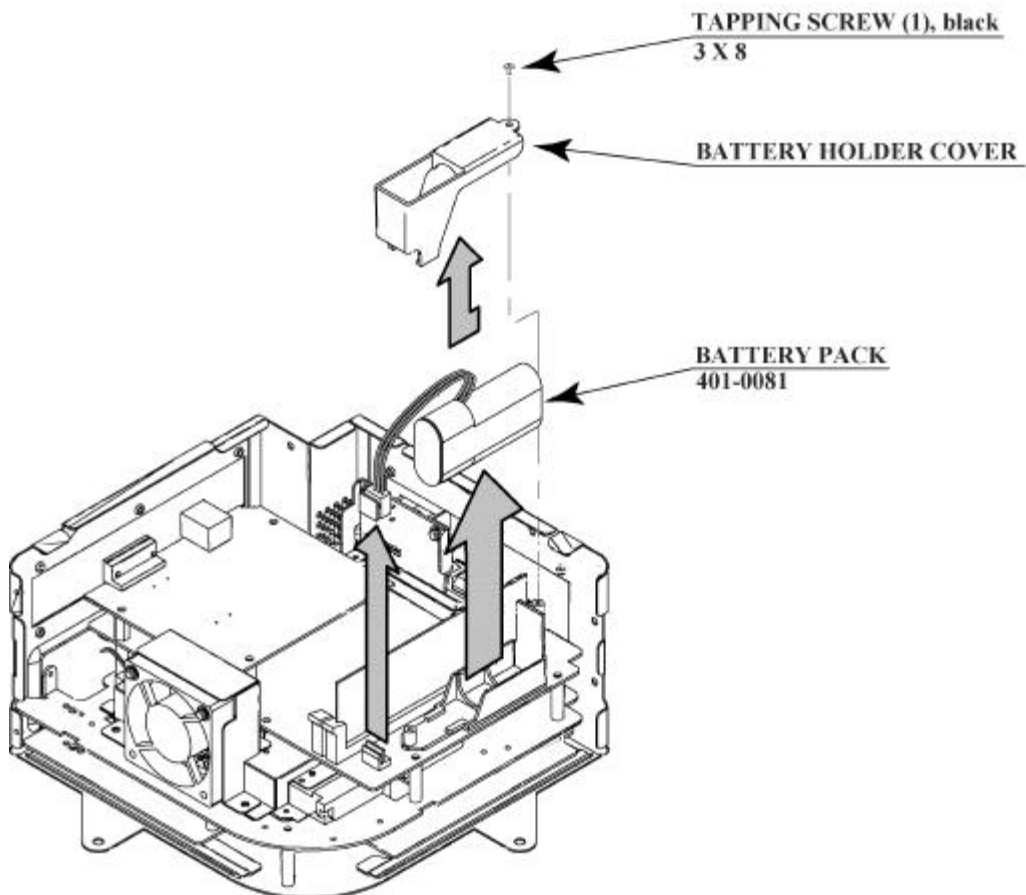

### 3.14.7. Shipping The Game Board And GD-ROM Drive

Observe the following precautions when sending the TRIFORCE or GD-ROM drive out for servicing or repairs.

The carton boxes (included) are needed to ship these parts, and should therefore be stored in a safe place to ensure that they are not lost.

- When sending parts in for repairs, they should be configured as follows:
  - (1) TRIFORCE:
    - Leave the key chip installed in the board.
  - (2) GD-ROM drive:
    - Remove the drive bracket.
    - Eject the GD-ROM disc, place it in its case, and store in a safe place.
- Remove the wire harnesses and cables from the TRIFORCE and GD-ROM drive before sending them in for repairs.
- Do not disassemble the TRIFORCE or GD-ROM drive. Place them in the carton box as is when sending them in for repairs.
- Provide a clear, detailed description of the game used and the observed problems when sending to the indicated repair center.

#### 3.14.7.1. How To Use The Triforce Carton Box

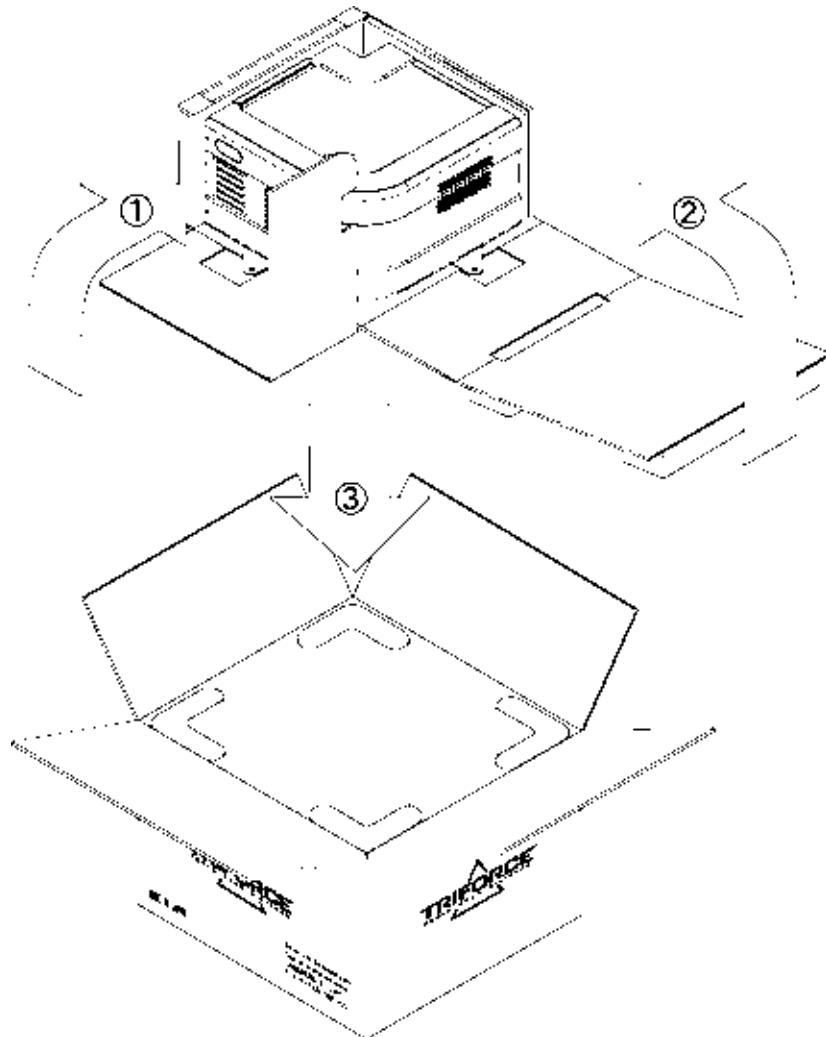

Fold the packaging in the order specified in the diagram and wrap it around the TRIFORCE, making sure that board and box are aligned correctly. Finally, place it in the carton box. Failure to wrap the product as specified in the diagram may cause damage to parts.

### 3.14.8. Machine Set Up

During linked play, if the test mode is not finished within three minutes on all linked machines, the NETWORK CHECK cannot be performed, causing a NETWORK ERROR.

First, set up each linked machine to meet the requirements of communication play. If the settings are incorrect, communication play is not possible.

SYSTEM ASSIGNMENTS	
CABINET TYPE	1PLAYER
ADVERTISE SOUND	ON
MONITOR TYPE	HORIZONTAL
SERVICE TYPE	COMMON
> EXIT	

SELECT WITH SERVICE BUTTON  
AND  
PRESS TEST BUTTON



### 3.14.8.1. Network Play

Up to 4 machines can be linked for network play. Properly connected network cables and correct network play settings are required for network play.

#### 3.14.8.1.1. Precautions Regarding Network Play Setup



- Before starting to work, ensure that the Power SW is OFF. Failure to observe this can cause electric shock or short circuit.
- Use care so as not to damage wirings. Damaged wiring can cause electric shock or short circuit.
- Do not touch undesignated places. Touching places not designated can cause electric shock or short circuit.
- This work should be performed by the site maintenance individual or other skilled professional. Performing work by non-technical personnel can cause electric shock hazard.
- When linking a number of machines, be sure to supply sufficient power for the corresponding number of machines. Be sure to secure per machine current as stated in this manual. Failure to observe this can cause a fire and an electric shock accident.
- Due to the length of the network cable, the distance in between the machines is limited. However, to avoid accidents, be sure to secure space in excess of 70 cm between the machines.
- To perform work safely and avoid serious accident such as the cabinet's falling down, do not perform work in places where step-like grade differences, a ditch, or slope exist.



- To perform work safely, be sure to secure the space corresponding to number of machines to be linked. Failure to observe this can cause accident.
- To avoid accidents, use a cable cover that will not cause patrons to trip when laying network cables in areas of heavy foot traffic.
- To prevent accidents and acts of vandalism, cover the network cables with the strongest cover possible.



- Network play is not possible between game machines with different cabinet types.

When connecting several games machines together, make sure that a sufficient amount of electrical power is available for each machine. Plan on providing 15A for each machine in 100-120V locations, and 7A in 220-240V locations.

### 3.14.8.1.1. Spacing of Game Machines

Leave at least 70 cm of space between game machines.

#### SPACING OF GAME MACHINES

BE SURE TO SECURE SPACE IN EXCESS OF THE DESCRIBED DISTANCE BETWEEN THE MACHINES.

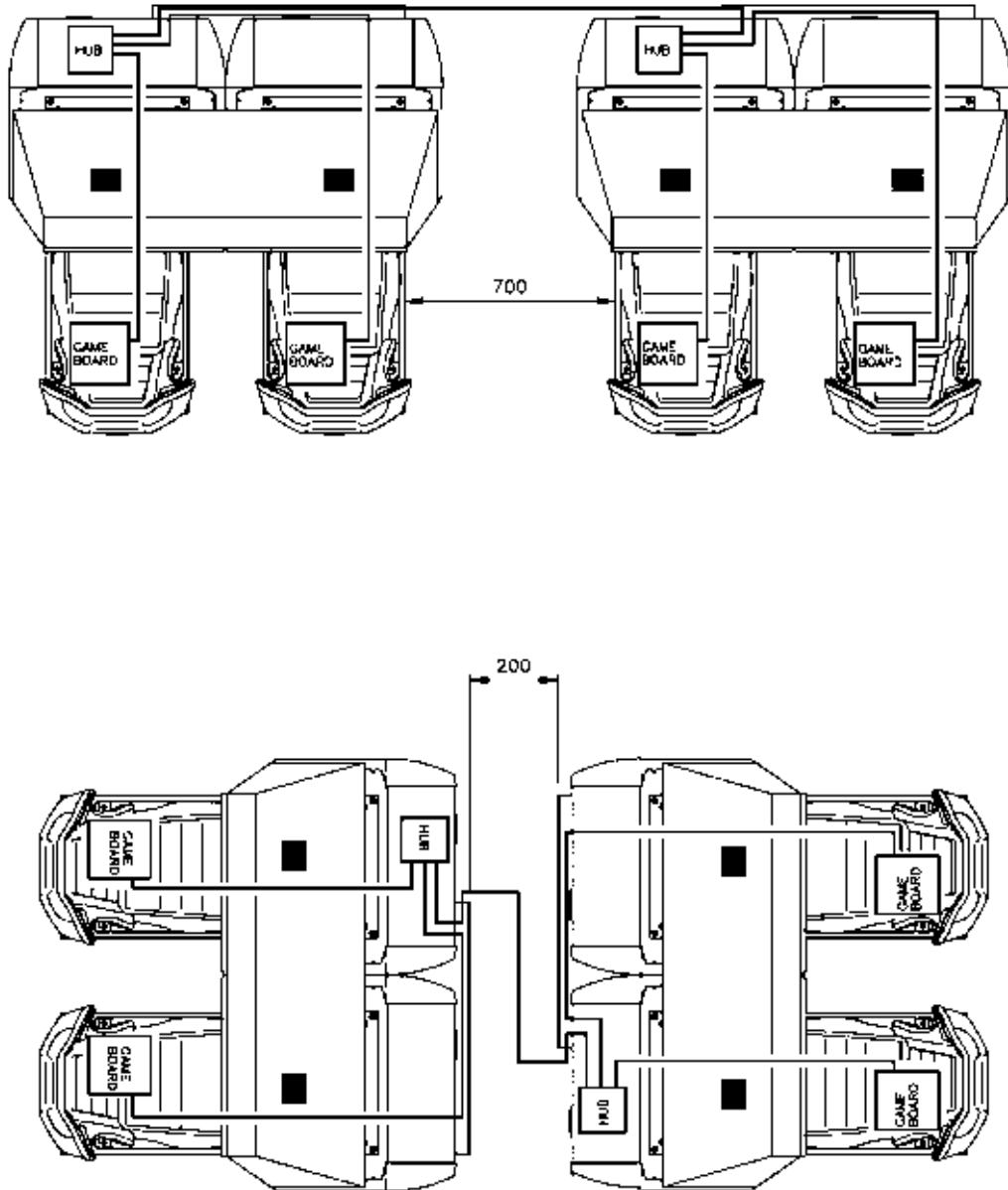

### 3.14.8.1.2.Connecting Network Cables

To enable network play, the hubs inside each of the game machines involved must be connected with network (LAN) cables. Connect the hub inside one of the machines to the hub in the other machine using LAN cables. There is no need to connect the other machines to each other in any other way.

Do not connect LAN cables between twin machines when they are not used for network play.

1. Turn off the power and unplug the power cord from the outlet. Place the power cord so as not to damage it while working.
2. Using the illustration on the previous as reference, move the machines so that they are lined up. Leave enough space on the front lid side of the machine to perform the rest of the operations in this procedure.
3. Remove the lower back lids of machines denoted 'L' on back.

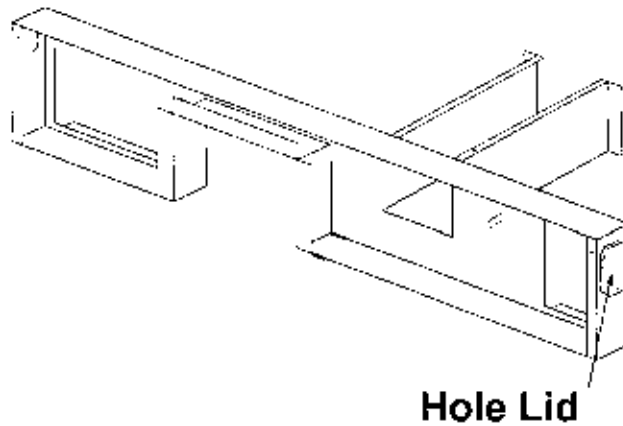

4. Remove the front covers on both machines.
5. Take off the required hole lids at the ends of the AC covers (see diagram above).
6. Route a spare LAN cable through both machines connecting both hubs.  
Any of the ports 2 or above can be used to connect to any of the other game machines.
7. Replace all lids and covers.
8. Once the machines have been linked for network play, line them up. Leave as much space as possible between the machines.
9. Secure all adjustors on each machine. (See Section 3.7.3)
10. Connect the power cord and grounding wire for each machine. (See 3.7.8)

### 3.14.8.1.3. Network Play Settings

Each of the linked machines must be set up for network play. If the machines are not set up correctly, network play will not be possible.

#### 3.14.8.1.3.1. How To Set Up A Machine For Network Play

1. Turn off the power on each machine to be used in network play.
2. Enter Test mode on each machine. (See Section 5.1)
3. Select GAME TEST MODE and press the TEST Button. The machine will enter Game Test mode and the screen will display the Game Test menu. (See Section 5.2.10)
4. Select NETWORK SETTINGS from the Game Test menu and press the TEST Button. The Network Settings screen will appear. Network settings are carried out on this screen.

```
NETWORK SETTING

LINK NUM 2(2•`4)
GROUP A(A•`Z)
NUMBER 2(1•`4)
-> EXIT

SELECT WITH SERVICE BUTTON
AND PRESS TEST BUTTON
```

5. Set the LINK NUM setting on the Network Settings screen to the number of game machines linked for network play.
6. Set up the GROUP setting on the Network Settings screen. The GROUP setting is used to divide the machines linked for network play into groups. For example, a network of 4 machines could be divided into 2 groups of 2 machines.
7. Set the NUMBER setting on the Network Settings screen so that each machine within a group has a different number. Make sure that one machine in each group is set to "1".
8. Exit Test mode on each machine. Be sure to choose EXIT from the System Test Menu to exit Test mode properly.
9. Once each machine has exited Test mode and gone through initialization, it will begin a network test. During the network test, the monitor will display a network test screen.
10. If there are no problems with network play settings or cable connections, the machine will enter Advertising mode.
11. If the advertising screen appears after the network test is finished, network settings are complete.
12. The network test should last roughly 20 to 30 seconds. If the network test screen fails to disappear, the problem is most likely due to one of the following: incorrect settings, an improperly connected LAN cable, a faulty LAN cable connection, or a severed wire.

### 3.14.8.1.4.General Precautions Regarding Network Play



- When setting up machines for network play, settings such as the game's difficulty level will be derived from the machine whose "NUMBER" is set to "1". If settings on machine "1" are changed, the other machines will have their settings changed accordingly. On machines other than "1", settings derived from machine "1" will not be displayed on screen and cannot be changed.
- Should a network connection fail during network play, gameplay will be suspended and the Network Error Screen will be displayed.
- If one of the units attached for network play enters Test Mode, the other unit will display the same Test Mode Screen.
- Even when units are connected for network play, each seat, each game may be given different cost settings. Incorrect cost settings may cause budget balancing problems.

Note that when 2 or more machines are linked together for network play, some functions are different than for stand-alone machines.

Whenever Test mode is used on a machine linked for network play, all machines connected to the network will display the network test screen. When patrons are engaged in network play, do not enter Test mode on any of the machines in the network, even if the machine is not in use.

However, machines whose GROUP setting is different from that of the machine entering Test mode will not be affected.

### 3.15. Periodic Check And Inspection

The items listed below require periodic check and maintenance to retain the performance of the machine and ensure safe operation:



- Be sure to check annually to see if the power cords are damaged. The plug is securely inserted and that there is no dust in the interior of the machine or between the socket and the power cord. Using the product in an unclean condition may cause a fire or electric shock.



- Only QUALIFIED SERVICE PERSONNEL should carry out periodic checks.

The items listed below require periodic check and maintenance to retain the performance of this machine and to ensure safe business operation.

When handling the controller, the player will be in direct contact with it . In order to always allow the player to enjoy the game, be sure to clean it regularly. Also, it is advisable to provide wet tissue, etc. available for player use.

ITEMS	DESCRIPTION	PERIOD
CABINET	Check Adjusters' contact with surface.	Daily
CARD READER/WRITER	Head cleaning	Every 151 counts of the card reader/writer or Daily
CONTROL PANEL	Cleaning	As necessary
	Inspection of VR	Monthly
	Inspection of adjusting gear mesh	Tri-monthly
	Greasing	Tri-monthly
SHIFT LEVER	Inspection of SW	Monthly
	Greasing	Tri-monthly
ACCEL. & BRAKE	Inspection of VR	Monthly
	Gear and Spring portion greasing	Tri-monthly
MONITOR	SCREEN cleaning.	Weekly
	Check adjustments.	Monthly or when moving.
COIN CHUTE DOOR	Inspection of COIN SW	Monthly
	Coin insertion test	Monthly
	Cleaning of COIN SELECTOR.	Tri-monthly
SEAT	Greasing to the seat rail	Tri-monthly
GAME BD	MEMORY TEST	Monthly
	Check settings.	Monthly
POWER SUPPLY PLUG	Inspection and cleaning	Annually
INTERIOR	Cleaning	As necessary
CABINET SURFACES	Cleaning	As necessary

## 4. HOW TO PLAY

### 4.1. Game Description

The following explanations apply to the case the product is functioning satisfactorily. Should there be any moves different from the following contents, some sort of faults may have occurred. Immediately look into the cause of the fault and eliminate the cause thereof to ensure satisfactory operation.

Whenever power is flowing to the machine, the fluorescent lamp is lit up. While in Advertising mode, the monitor will go through an advertising display loop, explaining the game's content and card system, displaying the rankings, and so on.

Sound is output from the speakers to the left and right of the monitor and on the left and right of the seat's headrest. Sound output during Advertising mode can be turned on or off by adjusting the corresponding setting in test mode.

The "Start" button and the 4 "View Change" buttons on top of the control panel are able to light up. They are not lit during Advertising mode.

The "Start" button will blink when enough credits have been inserted to play the game, and cease to blink when it is pressed to start the game. If there are still enough credits to play again after the game ends, the button will begin to blink again. After the race starts, the "View Change" button corresponding to the currently selected view will light up; all the others will remain unlit.

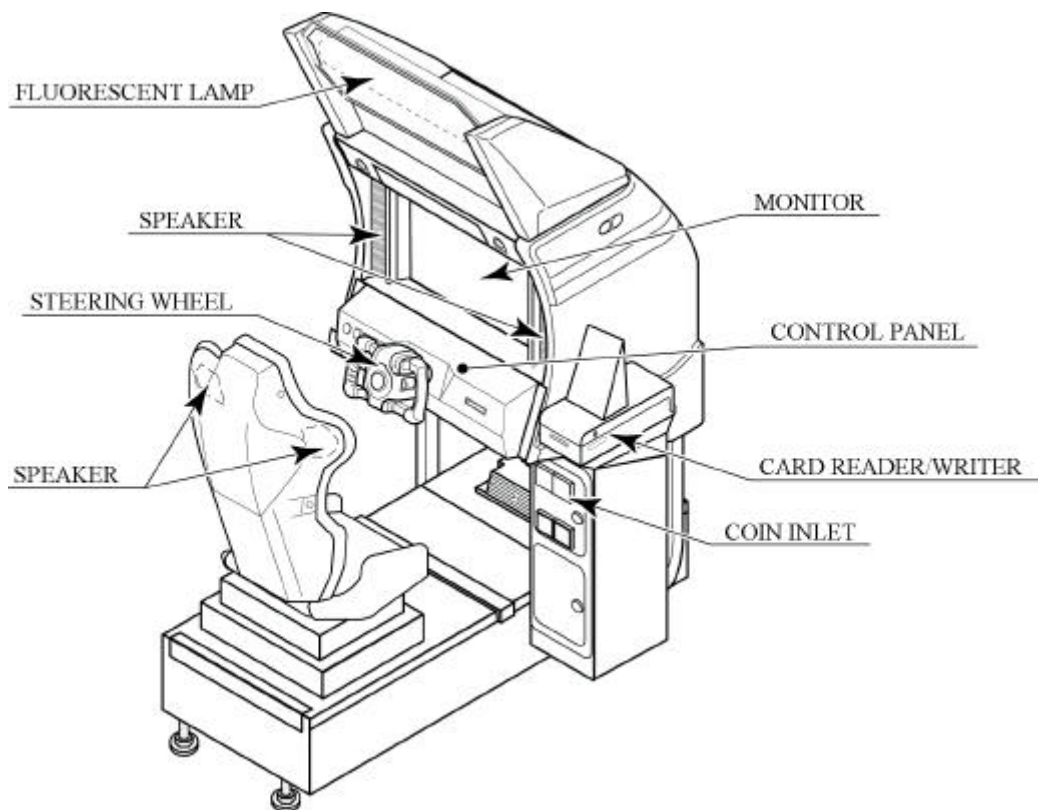

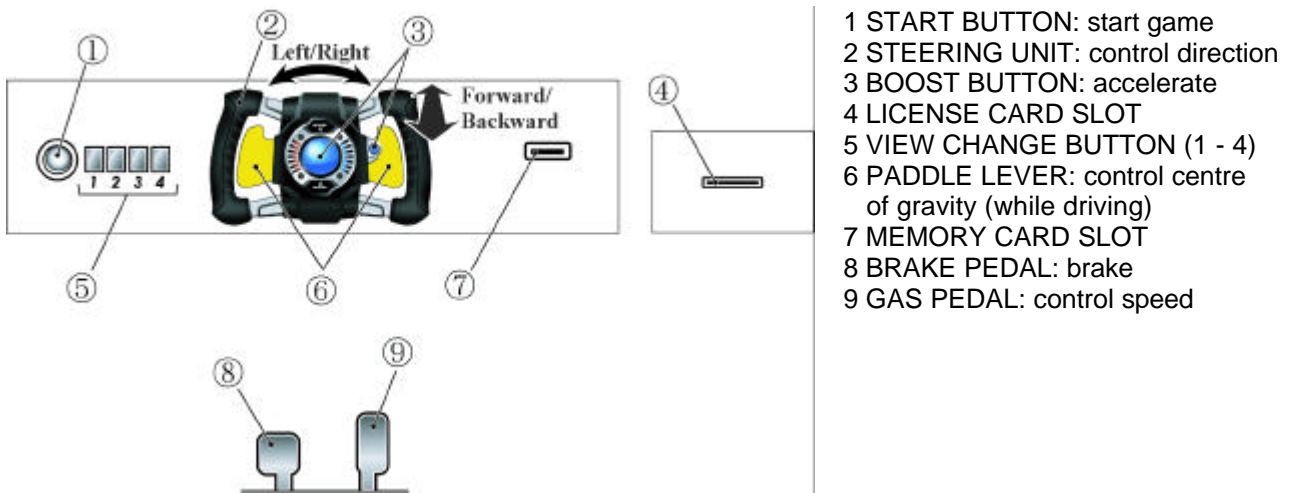

#### 4.1.1. Game Outline

This product is a racing game. It has two modes, RACE MODE and TIME ATTACK MODE. When the cabinets are connected (up to four cabinets), VERSUS PLAY is available. The game features six courses from which the players can choose freely. Each course has a time limit, and if you don't reach the goal within the time limit, your time is up and the race will end. Passing through checkpoints and control lines increases your time. Each course has a different number of checkpoints. A time penalty occurs when the player leaves the course and when his car explodes (energy goes to zero).

##### F-ZERO LICENSE CARD

You can receive your very own machine by purchasing a license card at the start of play. You can save player data to the card, including your name, pilot rank, pilot points, and time attack records. 1st-place data and numbers of wins are also recorded on the card.

##### Pilot Points

Use your license card to earn pilot points based on your play in Race and Time Attack Modes. Once you've collected enough points, you can get custom parts to customize your machine with!

##### Pilot Rank

Your pilot rank increases based on your play. Your rank can never decrease in this game.

##### NINTENDO GAMECUBE MEMORY CARD

Use your Memory Card to link the game with F-ZERO GX for Nintendo GameCube. But in order to use this special feature you must have F-ZERO GX game data on your card. Please note that the game cannot link with a Memory Card that does not contain F-ZERO GX game data.



## 4.1.2. Game Mode

### Race Mode

A single-course race. Thirty machines go head to head for first place. In linked play, players can go head-to-head against other players.

When using a license card, the game ends when the player takes first place on every course.

### Time Attack Mode

Race a set number of laps in time-trial format and fight for the best total time record. Ghost play is also available.

Internet rankings via PC are also planned. A license card is needed for Internet rankings.

### Internet Rankings

When PASSWORD DISP is set to OFF, the Internet Rankings guide is not shown during advertising.

When it is set to ON, a password is shown after playing Time Attack. Enter this password with a PC to join the F-ZERO Internet Rankings.

The rankings will be available on the F-ZERO Official Home Page (<http://f-zero.jp/>).

## 4.1.3. Playing the Game

### 4.1.3.1. The Card Check Screen

If you already have a license card, place it in the License Card Slot to continue automatically to the next screen. You can insert the Memory Card in this screen as well, but if you do not insert the Memory Card before the license card, it will not work properly.



### 4.1.3.2.The F-Zero License Card Screen

Press down on the accelerator in the Card Check Screen to move to the Purchase Screen. When creating a new card, insert the required number of coins to make a new license card. When your license card's credits have been used up, you will be moved to the Renewing Purchase Screen.

You can insert the Memory Card in this screen as well, but if you do not insert the Memory Card before the license card, it will not work properly.

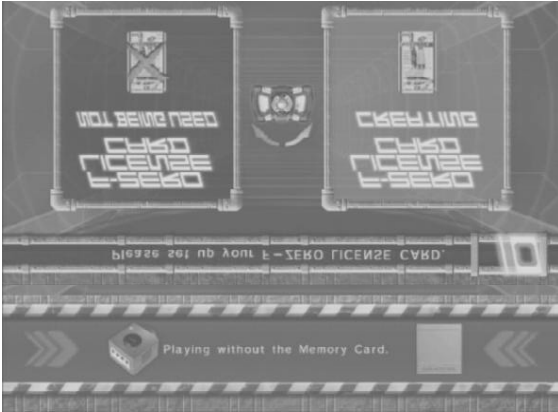

Creating a New Card



Renewing

### 4.1.3.3.The Name Entry Screen

(Shown the first time a license card is purchased)

When you purchase a new license card, you are moved to the Name Entry Screen.

(Inappropriate words will be changed into asterisks.)



### 4.1.3.4.The License Card Screen

(Not shown if a license card is not used)

Shows your personal car and play information.



#### 4.1.3.4.1. The Mode Select Screen

Choose either RACE MODE or TIME ATTACK MODE. Different descriptions will appear below based on the cabinet and Test Mode settings. In Versus Play, select the race mode while holding down the brake to bypass the Versus Screen.



#### 4.1.3.5. The Versus Screen

(When linked and playing Race Mode.)

When you choose Race Mode in the usual way, you will be taken to the Versus Screen. Empty cabinets will display a similar screen.

If you are using a license card, Race Mode-related data will appear. If others are also using license cards, you can take a look at their data. The layout of the screen differs according to the number of linked cabinets (though the information shown is the same).

\* You cannot skip this screen.

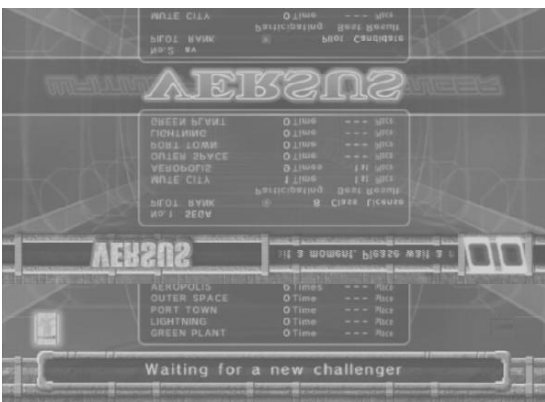

2 Cabinets Linked



3-4 Cabinets Linked

#### 4.1.3.6. The Course Select Screen

Select your favourite course from the six available. In Time Attack Mode, you can also configure Ghost settings. (Use the pedal lever to choose a ghost.) If you are using a License Card, you can look at information on each course. In Race Mode, wins, win percentage, and other data appear. In Time Attack Mode, total time, best lap, and max speed are shown.



Race Mode



Time Attack Mode

#### 4.1.3.7. The Machine Select Screen

Select your machine. You always get to choose machines, regardless of your card. The machines you can choose from change based on the card(s) you've inserted.

- No Card: Select from the default 14 machines.
  - License Card: Select from 15 machines, including your own on the far left.
  - Memory Card: Adds machines from your F-ZERO GX garage on the far right.
- If there are no cars in your F-ZERO GX garage, no machines will appear.



### 4.1.3.8. The Machine Setting Screen

Use the graph to configure your machine.

In multiplayer Race Mode, you can view other players' machines. If you are using a License Card in Time Attack Mode, you can look at best total times, machines used and settings.

If there is no data, NO DATA appears.



Race Mode



Time Attack Mode

### 4.1.3.9. Race

This is the racing screen. The basic controls of the machine are the steering wheel and the accelerator. You can use the booster after the second lap, so feel free to press the button in the centre of the steering wheel. When the booster is used, the energy drain rate increases. If energy reaches zero and your machine takes damage, your machine will flash red, you will be unable to move, and an official car will come with extra energy. If you leave the course, an official car will come to return your machine to the course.

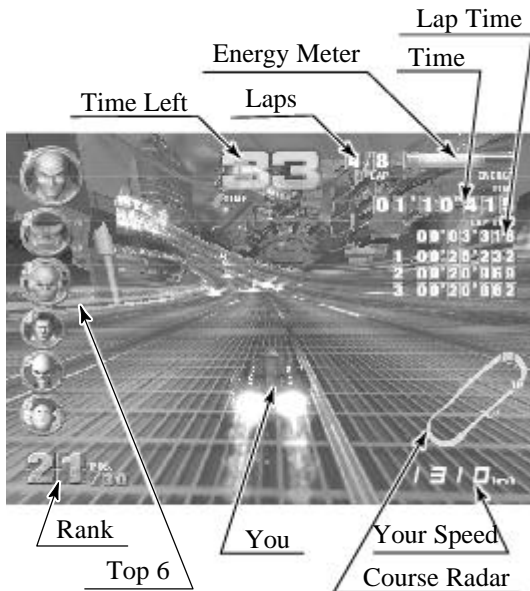

Race Mode



Time Attack Mode

#### 4.1.3.10.VS Result Screen

When you complete the race, the results of the race appear. Results do not appear when you retire. The display for COM races and multiplayer races are different in Race Mode. In Time Attack Mode, your personal best and other data are also shown if you use a license card.



Race Mode: COM



Race Mode: Multiplayer



Time Attack Mode

#### 4.1.3.11.Results Screen (Race Mode), Time Attack Ranking Screen (Time Attack Mode)

The Results Screen shows the results of the race, while the Time Attack Ranking Screen shows the best times recorded in the cabinet. When using a License Card, your username is automatically entered. If you are not using a License Card, you can enter a three-letter rankings name.



Race Mode



Time Attack Mode

#### 4.1.3.12.The Pilot Points Screen

(Only with License Card)

Gives you Pilot Points based on your race performance. Points are added and totalled for each category. When your Pilot Points exceed the required value, you are congratulated and moved to the Configuration Screen. This screen also informs you of Pilot Rank promotions.



#### 4.1.3.13.The Configuration Screen

(Only with a License Card and sufficient Pilot Points)

Lets you switch out your personal machine's parts and change pilots. Changing parts and pilots costs Pilot Points. When you change machine parts, the old parts are disposed of.



#### 4.1.3.14.Memory Card Screen

(Only with a Nintendo GameCube Memory Card inserted)

If you play with a Memory Card inserted and satisfy certain conditions, you can download special F-ZERO AX data to your Memory Card. You can then use the downloaded data in F-ZERO GX.



#### 4.1.3.15. The Password Screen

(Only with a License Card, when playing Time Attack Mode, and when the course has completed data)  
Once you complete a course in Time Attack Mode, you are taken to the Password Screen and given a password. This password is for your best total time. It is shown every time, but it is not necessarily the password for the race.

Enter the ID and name written to your License Card and the password shown on this screen into the F-ZERO Official Home Page to join the Internet Rankings. The Internet Rankings are announced on the F-ZERO Official Home Page (<http://f-zero.jp/>).

Set PASSWORD DISP to OFF in GAME ASSIGNMENTS in Test Mode to hide this screen.

You cannot continue to the next screen until the License Card is removed.



#### 4.1.3.16. The Game Over Screen

This screen is shown when the game is over. A reminder regarding your card is shown. And if your license card will need to be renewed next time, this screen will indicate that.





## 4.1.4. Other Warnings

### 4.1.4.1. Error Display

Basic errors related to magnetic cards and memory cards cause detailed instructions to appear on the screen. Mechanical errors in the cabinet, however, are displayed with error numbers. The following is a description of those errors. (See 18-3.)

Error 05 F Steering I/O Error

Error 06: Steering Overheat/Overload Error

Error 07: Steering Encoder Error

Error 08: Steering Excess Current Error

### 4.1.4.2. Secret Codes

**Race Mode: "No Versus"**

Description: Play by yourself, with no VERSUS screen.

To access: Hold down the brake when selecting a race mode in the MODE SELECT screen. This is explained in the MODE SELECT Screen help.

Note: No Versus cannot be used when there is only one cabinet.

**Race Mode: "VS BATTLE" (Human-only race)**

Description: A race with only human competitors. COM machines cannot join the race. For two to four players.

To access: Participants must hold down the brake when selecting their machine in the MACHINE SELECT screen.

Note: Cannot be used with only one cabinet or in one-player play. COM machines will always join.

**Race Mode: "No Handicap"**

Description: In Race Mode, cars in the rear are given supplemental speed and can go faster (player-controlled machines only). To turn off supplemental speed, use No Handicap.

To access: All players (even in one-player races) must hold down the brake when selecting a machine from the Machine Settings Screen.

Note: In Race Mode, even one-player games are handicapped, so use the above to turn handicapping OFF.

**Time Attack: Racing Staff Ghosts**

Description: Lets you race against Staff Ghosts

To access: Hold down the brake with the cursor on "Champion Ghost" in the Course Selection Screen and select a course.

## 5. MAINTENANCE INSTRUCTIONS

### 5.1. Explanation Of Test And Data Display

Use the switches on the VTS to enter the TEST MODE. This will allow you to carry out post installation and periodic checks and adjustments. The following Section details the function of each of the tests:



- Be very careful about entering TEST MODE. If the machine you wish to test is linked to other machines, exiting test on your machine will cause a network check to be carried out. This will disable all other machines linked to it.

ITEM	DESCRIPTION / REFERENCE	INTERVAL
INSTALLATION OF THE MACHINE	When the machine is installed perform the following checks: Check to see that each setting is as per the standard settings input at the time of shipment. In the INPUT TEST mode, check each switch and VR. Section 5.2.10.2. In the OUTPUT TEST mode, check each of the lamps. Section 5.2.10.3. In the MEMORY TEST mode check all of the IC's on the IC BD. Section 5.2.1	Monthly
MEMORY	On the TEST MENU screen choosing the MEMORY TEST allows self test to be performed. In this test RAM & ROM are tested.	Monthly
PERIODIC CHECKS	Periodically perform the following MEMORY TEST. Section 5.2.1. Ascertain each setting: In the INPUT TEST mode, test the control devices. Section 5.2.10.2. In the OUTPUT TEST mode, check each of the lamps. Section 5.2.10.3.	Monthly
CONTROL SYSTEM	In the INPUT TEST mode, check each switch and VR. Section 5.2.10.2. Adjust or replace each switch and VR. Section 3.9	Monthly
MONITOR	In the CRT TEST mode, check to ensure the monitor is adjusted correctly. Section 5.2.6 Clean screen (switch off machine and remove the plug)	Monthly Weekly
IC BOARD	MEMORY TEST In the SOUND TEST mode, check the sound related ROMs. 5.2.5	Monthly
DATA CHECK	Check such data as held in the bookkeeping screens, relating to number and length of plays. Section 5.2.10.8.	Monthly
EXTERIOR MAINTENANCE	Clean surfaces Lubricate seat sliders	Monthly
COIN MECHANISM	Check switch operation (if fitted)	Monthly

### 5.1.1. VTS Assembly



- Do not touch places other than those specified. Touching places not specified could cause an electric shock or short circuit.



Opening the Coin Chute door will reveal the VTS Assembly shown above. The function of each switch is as follows. The controls on the left affect the 1P cockpit, those on the right the 2P

TEST BUTTON (TEST SW)	Used to enter TEST mode. Also has function during TEST mode. Refer to the later Section detailing TEST mode.
SERVICE BUTTON (SERVICE SW)	Gives credits without registering on the coin counter. Also used during TEST mode.
DEMAG	Demagnetises (degausses) the CRT to remove colour unevenness.
VOLUME MAIN	Adjusts the volume of the left and right main speakers.
VOLUME WOOFER	Adjusts the volume of the woofer.

## 5.2. System Test Mode



- The contents of settings changed in the TEST mode are stored when the test mode is finished from EXIT in the menu mode. If the power is turned off before the TEST mode is finished, the contents of setting change become ineffective.
- Executing "BACKUP DATA CLEAR" in the SYSTEM TEST MODE does not clear the BOOKKEEPING data in the GAME TEST mode.
- Entering the TEST mode clears fractional number of coins less than one credit and BONUS ADDER data.
- Perform setting as per specified in this manual for operation. If setting not specified is performed for operation, proper function of this product may not be obtained.

In the SYSTEM TEST MODE, IC BD functioning can be checked, the monitor adjusted, and the coin setting performed.

Refer to NAOMI NETWORK SYSTEM SERVICE MANUAL for the details. Note that the setting of the following items need to be performed in accordance with the instruction given.

CABINET TYPE : 1 PLAYER(S)  
 MONITOR TYPE : HORIZONTAL  
 SERVICE TYPE : COMMON  
 COIN CHUTE TYPE : COMMON  
 NETWORK TYPE : NONE

The SEQUENCE SETTING items of COIN/CREDIT SETTING are as follows.

### SEQUENCE SETTING

SEQUENCE 1: Number of credits required for starting the game.  
 SEQUENCE 2: Number of credits required for continuing the play.  
 SEQUENCE 3: Number of credits required for dedicated CARD purchase.  
 SEQUENCE 4 -8: NOT USED

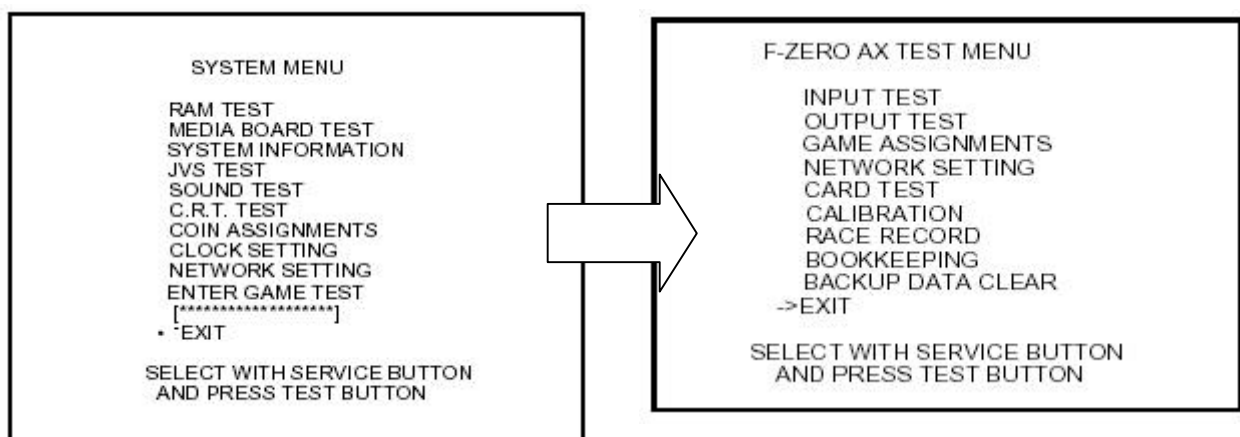

Press the TEST BUTTON to bring up the screen shown to the left.  
 Press the SERVICE BUTTON to move downwards through the list. The arrow shows the current selection.  
 Press the TEST BUTTON to activate the selected test.  
 To finish TEST MODE, move the arrow to EXIT and press the TEST.

### 5.2.1. RAM Test

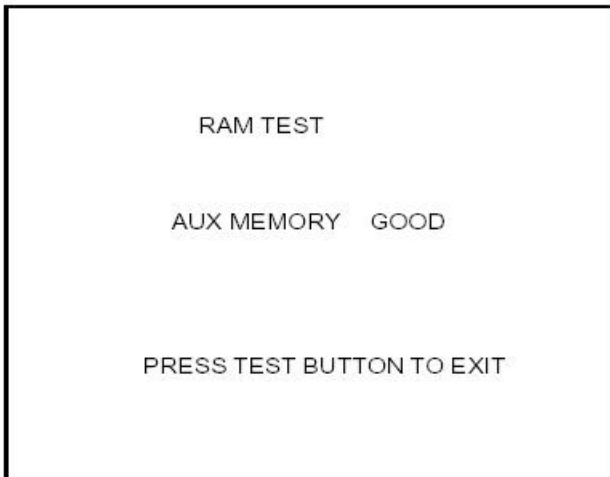

The memory test mode is for automatically checking the on-board memory IC functioning. "GOOD" is displayed for normal IC's and "BAD " for abnormal IC's

- When the test is completed, if the results are similar to those shown on the left then the Game Board is satisfactory.
- The test should take approximately thirty seconds to complete. If the test exceeds this time the board may have malfunctioned.
- After finishing the test press the TEST BUTTON or START BUTTON to exit.

## 5.2.2. Media Board Test



- Powering off the system during the MEDIA BOARD TEST with a DIMM BOARD will erase the game programme data. It may be necessary to reload the data.
- Always wait for the test to complete before attempting to exit.

MEDIA BOARD TEST is used to check the memory and IC on the MEDIA BOARD connected to the TRIFORCE. Test screens and test times may differ depending on the type of MEDIA BOARD connected to the unit.

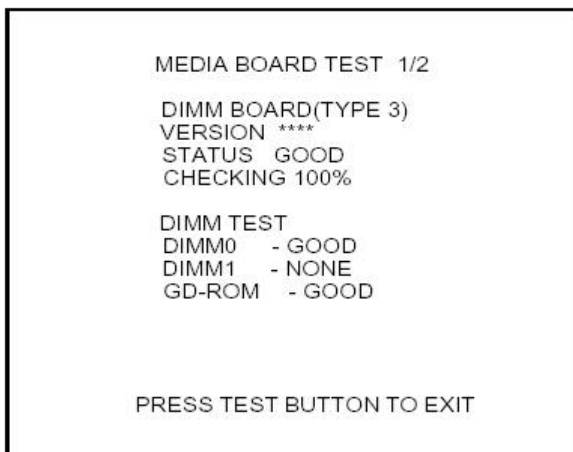

1. MEDIA BOARD TEST begins immediately upon entering this test mode.
2. If "GOOD" is displayed to the right of each item, the MEDIA BOARD components are functioning properly.
3. Press the TEST Button to move to Screen 2/2.
4. Press the TEST Button on Screen 2/2 to return to the System Menu screen.

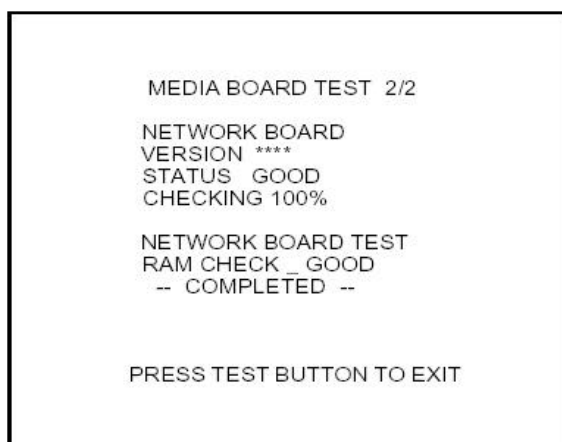

### 5.2.3. System Information

Use SYSTEM INFORMATION to check version and other information for system programmes. Screens may differ depending on the type of MEDIA BOARD connected to the unit.

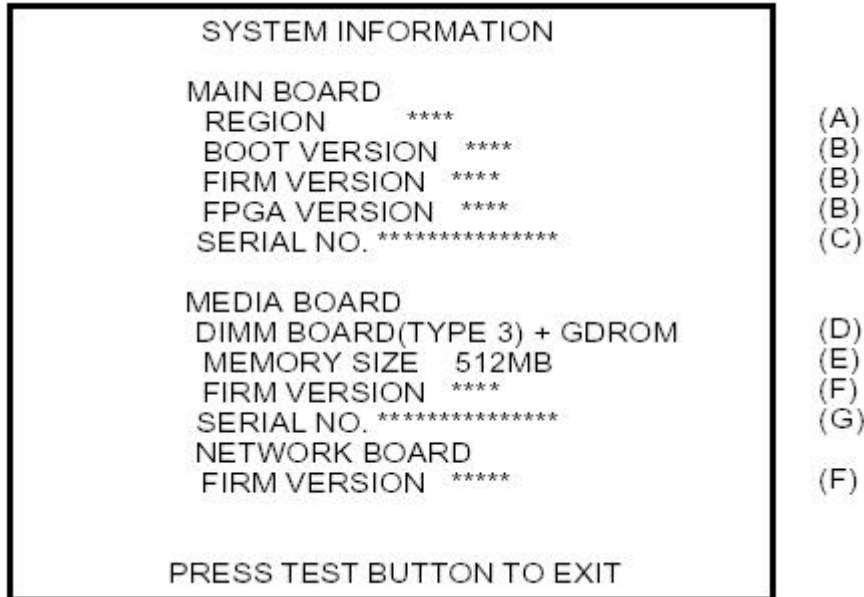

Press the TEST Button to return to the SYSTEM MENU screen.

- A. REGION  
The COUNTRY CODE of the MAIN BOARD.
- B. BOOT VERSION, FIRM VERSION, FPGA VERSION  
Version information for the MAIN BOARD system programmes.
- C. SERIAL NO.  
Serial number of the MAIN BOARD.
- D. DIMM BOARD + GDROM  
Type of MEDIA BOARD. This example shows a DIMM BOARD (TYPE 3) with a GD-ROM DRIVE connected.
- E. MEMORY SIZE  
Capacity of DIMM memory installed on the DIMM BOARD.
- F. FIRM VERSION  
Version information for the DIMM BOARD system programme.
- G. SERIAL NO.  
Serial number of the DIMM BOARD.

## 5.2.4. JVS Test

```
                JVS TEST
                INPUT TEST
                > EXIT

NODE           1/1
NAME           SEGA ENTERPRISES, LTD. :837-13741
                I/O CONTROL, BD2;Ver0.15;99/06
CMD VER       1.1
JVS VER       2.0
COM VER       1.0
SWITCH        2PLAYERS 12BITS
COIN          2SLOTS
ANALOG        BCH
DRIVER OUT    22CH

                SELECT WITH SERVICE BUTTON
                AND
                PRESS TEST BUTTON
```

- In this test, functioning of the I/O Board connected to the Game Board is displayed, and INPUT TEST can be performed. Select EXIT to return to the MENU screen, or select INPUT TEST to display the second screen.

```
                JVS TEST
                > DISPLAY CONFIG
                EXIT

NODE           1/1
SWITCH        . . . . .
SYSTEM        -----
PLAYER1       -----
PLAYER2       -----
COIN          SLOT1 0000  SLOT2 8000
ANALOG        -----
CH1 0000 CH2 0000 CH3 0000 CH4 0000
CH5 0000 CH6 0000 CH7 0000 CH8 0000

                SELECT WITH SERVICE BUTTON
                AND
                PRESS TEST BUTTON
```

With a switch input from the control panel etc., this changes into 1.

With a coin switch input, this accumulates. And, the coin meter counts.

Analogue values are displayed between 0000 and FF00.

Select EXIT to return to the MENU screen.



### 5.2.5. Sound Test

Select the sound test to check the status of the amplifiers, soundboards, and speakers.

Press the SERVICE button or view change button to move the arrow to the desired test item.

Press TEST button to output the sound.



- Select the sound source with SERVICE.
- On pressing TEST, the test sound is emitted from the selected source.

Select EXIT to return to MENU screen.

### 5.2.6. C.R.T Test

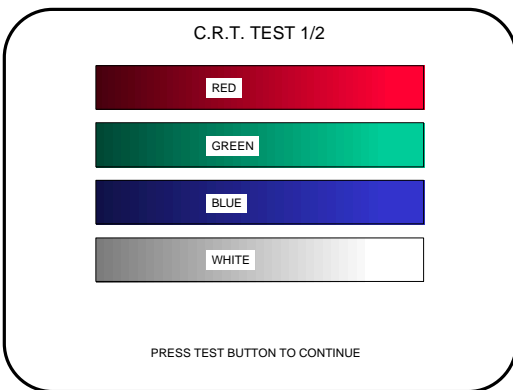

Selecting CRT test allows the projector adjustment to be checked for colour and distortion.

Press the test or start button to have the second CRT test screen appear.

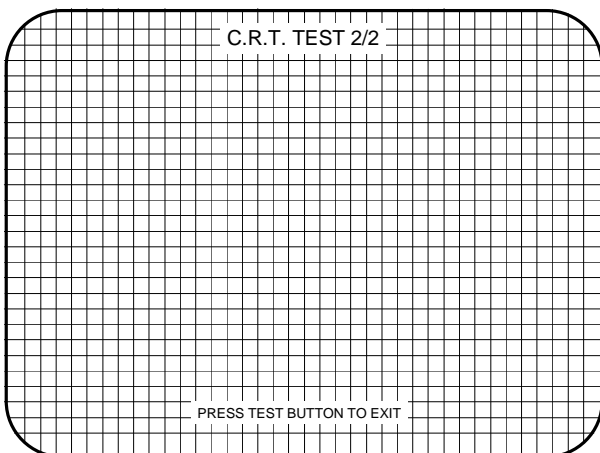

## 5.2.7. System Assignments

Allows system options to be set. Select required setting with SERVICE button, confirm with TEST button. Default settings are indicated in parentheses.

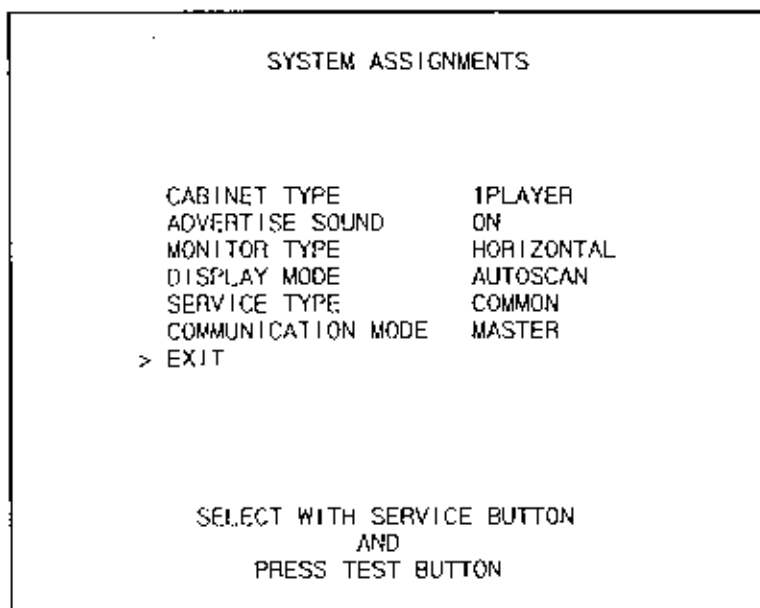

- CABINET TYPE specifies Control Panel and number of Coin Chutes. The number of players displayed in BOOKKEEPING varies in accordance with the value displayed here. (**1PLAYER**)
- ADVERTISE SOUND allows the sound emission to be turned (**ON**) or OFF during ADVERTISE MODE.
- MONITOR TYPE changes the orientation of the image on the screen (**HORIZONTAL**)
- SERVICE TYPE sets the functioning of the SERVICE button, should several SERVICE buttons exist.  
**INDIVIDUAL**: Service credit is applied to the machine on which the SERVICE button is pressed.  
**(COMMON)**: Service credit is applied to all machines when SERVICE button is pressed.

### 5.2.7.1. Coin Assignments

Select the coin assignments mode to set the coin to credit ratios.

This can be any of the pre-set values or can be done manually.

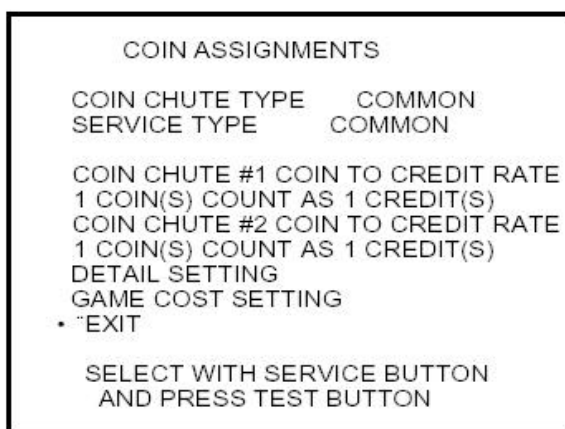

Coin Chute Type - Common

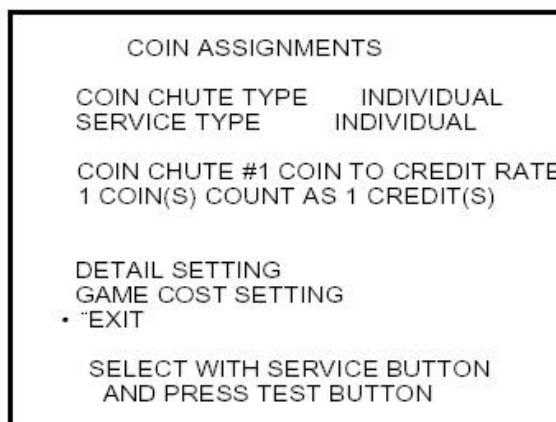

Coin Chute Type - Individual

### 5.2.7.2.Coin/Credit Setting (Coin Chute Common Type)

SETTING	FUNCTIONING OF COIN CHUTE #1		FUNCTIONING OF COIN CHUTE #2	
SETTING #1	1 COIN	1 CREDIT	1 COIN	1 CREDIT
SETTING #2	1 COIN	2 CREDITS	1 COIN	1 CREDIT
SETTING #3	1 COIN	3 CREDIT	1 COIN	1 CREDIT
SETTING #4	1 COIN	4 CREDITS	1 COIN	1 CREDIT
SETTING #5	1 COIN	5 CREDITS	1 COIN	1 CREDIT
SETTING #6	1 COIN	2 CREDITS	1 COIN	2 CREDITS
SETTING #7	1 COIN	5 CREDITS	1 COIN	2 CREDITS
SETTING #8	1 COIN	3 CREDITS	1 COIN	3 CREDITS
SETTING #9	1 COIN	4 CREDITS	1 COIN	4 CREDITS
SETTING #10	1 COIN	5 CREDITS	1 COIN	5 CREDITS
SETTING #11	1 COIN	6 CREDITS	1 COIN	6 CREDITS
SETTING #12	2 COINS	1 CREDIT	2 COINS	1 CREDIT
SETTING #13	1 COIN	1 CREDIT	2 COINS	1 CREDIT
SETTING #14	1 COIN	2 CREDITS	2 COINS	1 CREDIT
SETTING #15	1 COIN	1 CREDIT	1 COIN	1 CREDIT
	2 COINS	3 CREDITS	2 COINS	3 CREDITS
SETTING #16	1 COIN	3 CREDITS	1 COIN	1 CREDIT
			2 COINS	3 CREDITS
SETTING #17	3 COINS	1 CREDIT	3 COINS	1 CREDIT
SETTING #18	4 COINS	1 CREDIT	4 COINS	1 CREDIT
SETTING #19	1 COIN	1 CREDIT	1 COIN	1 CREDIT
	2 COINS	2 CREDITS	2 COINS	2 CREDITS
	3 COINS	3 CREDITS	3 COINS	3 CREDITS
	4 COINS	5 CREDITS	4 COINS	5 CREDITS
SETTING #20	1 COIN	5 CREDITS	1 COIN	1 CREDIT
			2 COINS	2 CREDITS
			3 COINS	3 CREDITS
			4 COINS	5 CREDITS
SETTING #21	5 COINS	1 CREDIT	5 COINS	1 CREDIT
SETTING #22	1 COIN	2 CREDITS	3 COINS	1 CREDIT
			5 COINS	2 CREDITS
SETTING #23	2 COINS	1 CREDIT	2 COINS	1 CREDIT
	4 COINS	2 CREDITS	4 COINS	2 CREDITS
	5 COINS	3 CREDITS	5 COINS	3 CREDITS
SETTING #24	1 COIN	3 CREDITS	2 COINS	1 CREDIT
			4 COINS	2 CREDITS
			5 COINS	3 CREDITS
SETTING #25	1 COIN	1 CREDIT	1 COIN	1 CREDIT
	2 COINS	2 CREDITS	2 COINS	2 CREDITS
	3 COINS	3 CREDITS	3 COINS	3 CREDITS
	4 COINS	4 CREDITS	4 COINS	4 CREDITS
	5 COINS	6 CREDITS	5 COINS	6 CREDITS
SETTING #26	1 COIN	6 CREDITS	1 COIN	1 CREDIT
			2 COINS	2 CREDITS
			3 COINS	3 CREDITS
			4 COINS	4 CREDITS
			5 COINS	6 CREDITS
SETTING #27	FREE PLAY		FREE PLAY	

### 5.2.7.3.Coin/Credit Setting (Coin Chute Individual Type)

SETTING	FUNCTIONING OF COIN CHUTE #1	
SETTING #1	1 COIN	1 CREDIT
SETTING #6	1 COIN	2 CREDITS
SETTING #8	1 COIN	3 CREDITS
SETTING #9	1 COIN	4 CREDITS
SETTING #10	1 COIN	5 CREDITS
SETTING #11	1 COIN	6 CREDITS
SETTING #12	2 COINS	1 CREDIT
SETTING #15	1 COIN	1 CREDIT
	2 COINS	3 CREDITS
SETTING #17	3 COINS	1 CREDIT
SETTING #18	4 COINS	1 CREDIT
SETTING #19	1 COIN	1 CREDIT
	2 COINS	2 CREDITS
	3 COINS	3 CREDITS
	4 COINS	5 CREDITS
SETTING #21	5 COINS	1 CREDIT
SETTING #22	3 COINS	1 CREDITS
	5 COINS	2 CREDITS
SETTING #23	2 COINS	1 CREDIT
	4 COINS	2 CREDITS
	5 COINS	3 CREDITS
SETTING #25	1 COIN	1 CREDIT
	2 COINS	2 CREDITS
	3 COINS	3 CREDITS
	4 COINS	4 CREDITS
	5 COINS	6 CREDITS
SETTING #27	FREE PLAY	

### 5.2.7.3.1.Detail Setting

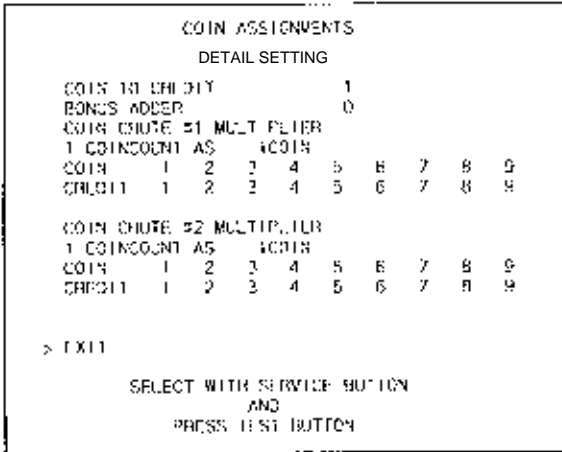

Select manual setting to manually set the coin to credit ratios.

The available combinations are detailed below.

COIN TO CREDIT	1 COIN	1 CREDIT
	2 COINS	1 CREDIT
	3 COINS	1 CREDIT
	4 COINS	1 CREDIT
	5 COINS	1 CREDIT
	6 COINS	1 CREDIT
	7 COINS	1 CREDIT
	8 COINS	1 CREDIT
	9 COINS	1 CREDIT

BONUS ADDER	NO BONUS ADDER
	2 COINS GIVE 1 EXTRA COIN
	3 COINS GIVE 1 EXTRA COIN
	4 COINS GIVE 1 EXTRA COIN
	5 COINS GIVE 1 EXTRA COIN
	6 COINS GIVE 1 EXTRA COIN
	7 COINS GIVE 1 EXTRA COIN
	8 COINS GIVE 1 EXTRA COIN
	9 COINS GIVE 1 EXTRA COIN

COIN CHUTE MULTIPLIER	1 COIN COUNTS AS 1 COIN
	1 COIN COUNTS AS 2 COINS
	1 COIN COUNTS AS 3 COINS
	1 COIN COUNTS AS 4 COINS
	1 COIN COUNTS AS 5 COINS
	1 COIN COUNTS AS 6 COINS
	1 COIN COUNTS AS 7 COINS
	1 COIN COUNTS AS 8 COINS
1 COIN COUNTS AS 9 COINS	

### 5.2.7.3.2.Game Cost Setting

Use this mode to set the number of credits required to start a game and buy a license card.

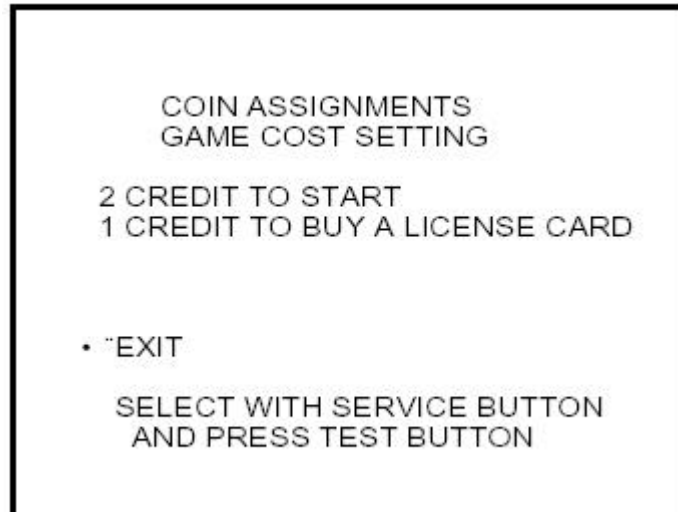

### 5.2.8. Clock Setting

Use CLOCK SETTING to set the TRIFORCE internal clock.

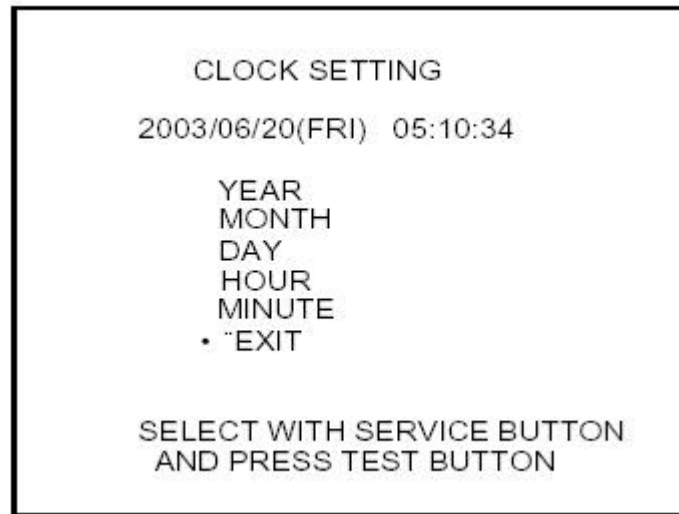

1. Use the SERVICE Button to move the cursor to the item to be set.
2. Move the cursor to the desired item and press the TEST Button to increase values. The max value for YEAR is "2099"; further increases return the value to "2000".
3. Move the cursor to EXIT and press the TEST Button to return to the SYSTEM MENU screen.

## 5.2.9. Network Setting



- This product should only be used with the factory settings indicated in this manual. Selecting certain options from the screens listed below may alter settings or bring up other screens. However, since these functions are not used by this machine, they are not described in this manual.
- In the event that settings are altered on a screen not mentioned in this manual, the machine may cease to function properly. Restore the settings to the values shown on the screens below. Refer to 3.14.8.1 for actual network play settings.

Use NETWORK SETTING to establish and test network connections.

1. Use the SERVICE Button to move the cursor to the desired test item.
2. Press the TEST Button to change the setting or to open the detailed settings.
3. Move the cursor to EXIT and press the TEST Button to return to the SYSTEM MENU screen.

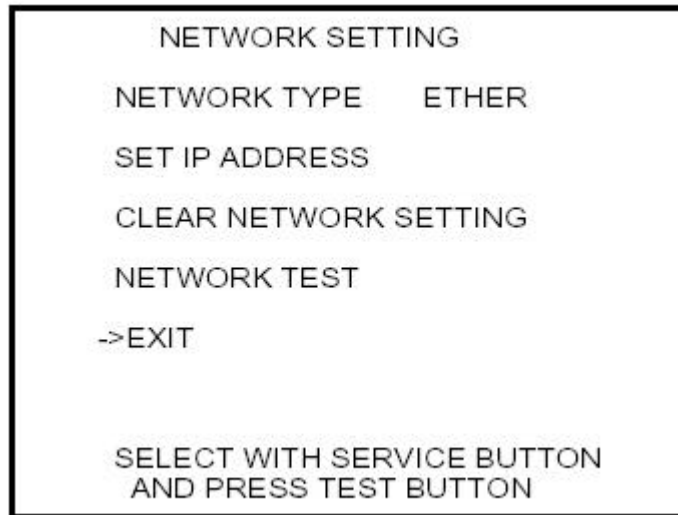

### NETWORK TYPE

Choose a type of the communication network.  
Set to ETHER in this game machine.

NONE	Sets that the communication system does not perform. Sets to none when you don't set the network system
ETHER	Sets ETHER for the communication network.
MOBILE	Sets a mobile communication terminal for the communication network.
ETHER+MOBILE DEFAULT ETHER	Set ETHER or MOBILE automatically for the communication network. Priority is given to ETHER.
ETHER+MOBILE DEFAULT MOBILE	Set ETHER or MOBILE automatically for the communication network. Priority is given to MOBILE.



## SET IP ADDRESS

This sets up the details of the communication network. Depending on the NETWORK TYPE setting, the contents of setting vary. If setting to NONE, it does not appear.

### *ETHER Setting*

```
SET IP ADDRESS 1/1
REMOTE DISABLE (C)
IP ADDRESS(E)
*****
SUBNET MASK(E)
-----
GATEWAY(E)
-----
PRIMARY DNS
-----
SECONDARY DNS
-----
->EXIT
SELECT WITH SERVICE BUTTON
AND PRESS TEST BUTTON
```

## REMOTE

This option determines whether network settings will be handled automatically.

For this machine, the option should be set to DISABLE.

The other items are set up automatically. It's not necessary to change anything.

## 5.2.10. Game Test Mode



- When changing the game configuration, changes will not be enabled until the Game Test Mode has been completed. Be sure to exit the Game Test Mode properly after configuration changes.
- Do not configure the game in ways not described in this text, as this may lead to game malfunctions.

### 5.2.10.1. Game Test Menu

Select GAME TEST MODE from the System Menu screen to display the Game Test Menu screen as follows.

Use the SERVICE Button to move the cursor to the desired test item. Press the TEST Button to enter the selected item.

After selecting an item, read the explanations below regarding operation.

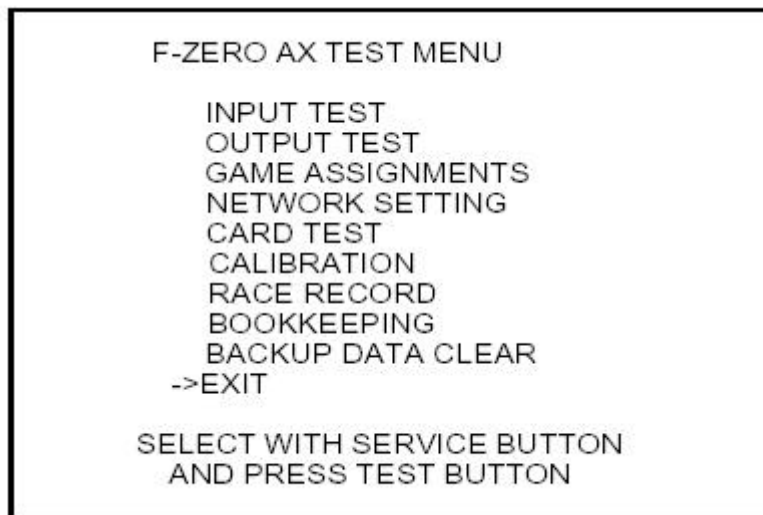

After making changes, be sure to select EXIT and press the TEST Button in order to enable the new settings.

Move the cursor to EXIT and press the TEST Button to return to the System Menu screen.

## 5.2.10.2.Input Test

Select INPUT TEST to display the following screen and check the status of input devices.  
This test should be used periodically to check that each input device is functioning correctly.

INPUT TEST			
STEERING X	0(~FF)	SERVICE	OFF(ON)
STEERING Y	0(~FF)	TEST	OFF(ON)
PADDLE LEFT	OFF(ON)		
PADDLE RIGHT	OFF(ON)		
BOOST	OFF(ON)		
GAS	0(~FF)		
BRAKE	0(~FF)		
START BUTTON			
VIEW CHANGE 1	OFF(ON)		
VIEW CHANGE 2	OFF(ON)		
VIEW CHANGE 3	OFF(ON)		
VIEW CHANGE 4	OFF(ON)		
PRESS TEST AND SERVICE BUTTON TO EXIT			

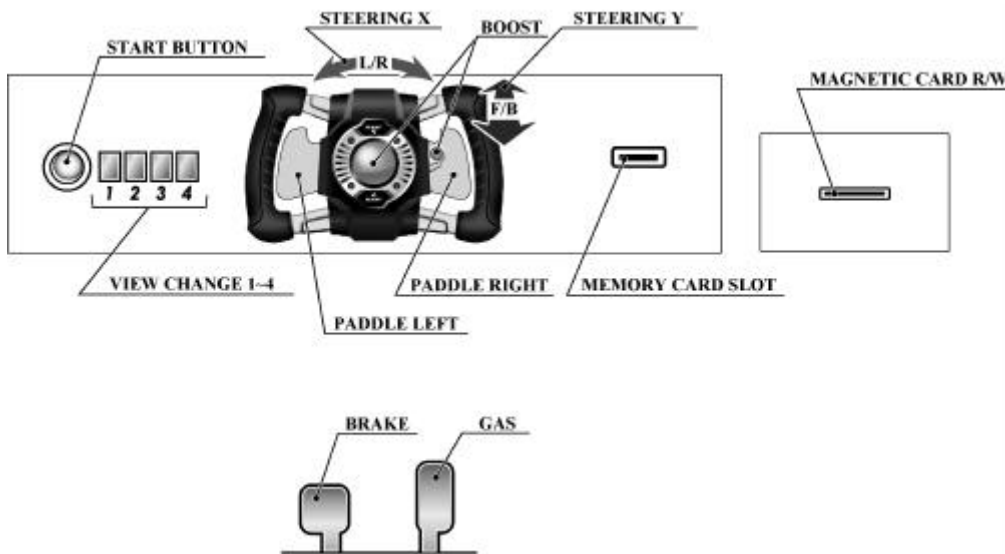

Test the STEERING, GAS and BRAKE controls to ensure that they are functioning properly and that the parameters change smoothly as each input device is operated.

If the other input devices (switches, buttons, sensors) switch from "OFF" to "ON" when operated, they are functioning normally.

Press the SERVICE and TEST Buttons simultaneously to return to the Game Test Menu screen.

### 5.2.10.3. Output Test



- Select STEERING and press the TEST Button to make the steering wheel turn. To avoid injury, first make sure that no one is touching the wheel.
- To avoid injury, first check that no one is touching the steering wheel. Select OUTPUT TEST and press the TEST Button. After initialization the steering wheel will turn.

Selecting OUTPUT TEST and pressing the TEST Button will cause the next screen to initialize and load. This allows you to check the status of each output device.

This test should be used periodically to check that the lamps are functioning correctly.

OUTPUT TEST	
START BUTTON	OFF(ON)
VIEW CHANGE 1	OFF(ON)
VIEW CHANGE 2	OFF(ON)
VIEW CHANGE 3	OFF(ON)
VIEW CHANGE 4	OFF(ON)
BOOST	OFF(ON)
STEERING	
CENTER	OFF(ON)
LEFT	OFF(ON)
RIGHT	OFF(ON)

-> EXIT

SELECT WITH SERVICE BUTTON  
AND PRESS TEST BUTTON

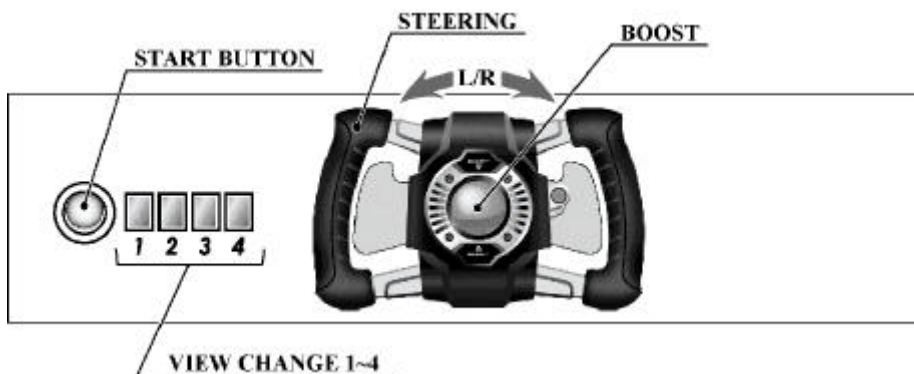

The START BUTTON, VIEW CHANGE 1-4, and BOOST allow you to check the status of the lights on top of the control panel. Select each item and press the TEST Button to turn the respective light on and off as indicated by the display to the right of the item.

Come to this screen periodically to check that the lamps light up with ON and turn off with OFF.

When you select STEERING or SEAT and press the TEST Button, it will move in the selected direction for a set period of time and stop. SEAT LOCK locks the seat in place.

Move the cursor to EXIT and press the TEST Button to return to the Game Test Menu screen.

## 5.2.10.4. Game Assignments

Select GAME ASSIGNMENTS to display the current game settings and make changes.

Periodically come to this screen to check game settings.

GAME•ASSIGNMENTS	
ADVERTISE SOUND	ON (OFF)
FORCE FEEDBACK	2 (1~3)
MAGNETIC CARD R/W USE	ON (ON? OFF? OUT OF SERVICE)
MEMORY CARD SLOT USE	OFF (OFF? OUT OF SERVICE? ON)
GAME DIFFICULTY	NORMAL (VERY EASY? EASY? NORMAL ? HARD? HARDEST)
HANDICAP	ON (OFF)
VS BATTLE MODE	OFF (ON)
PASSWORD DISP	OFF (ON)
RACE MODE LAPS	NORMAL (SET1~5)
1[Sonic Oval]	8 ( 10? 15? 20? 30? 40)
2[Screw Drive]	6 ( 8? 10? 15? 20? 30)
3[Meteor Stream]	4 ( 6? 8? 10? 15? 20)
4[Cylinder Wave]	3 ( 5? 7? 9? 10? 15)
5[Thunder Road]	3 ( 5? 7? 9? 10? 15)
6[Spiral]	3 ( 5? 7? 9? 10? 15)
-> EXIT	
SELECT WITH SERVICE BUTTON AND PRESS TEST BUTTON	

Press the SERVICE Button and move the cursor to the setting you wish to change. Press the TEST Button to cycle the parameters on the left of the item through its various settings.

Note that GAME DIFFICULTY, HANDICAP, VS BATTLE MODE, PASSWORD DISP and RACE MODE LAPS are shown on the machine whose NUMBER on the NETWORK SETTING screen is set to 1.

Changing the configuration of the NUMBER 1 machine automatically follows the settings of the other numbered machines.

### **ADVERTISE SOUND**

Turn advertising sound output ON and OFF.

(Default setting: ON)

### **FORCE FEEDBACK**

There are three settings for steering resistance. (Default setting: 2)

1: Weak

2: Normal

3: Strong

### **MAGNETIC CARD R/W USE**

Configure the usability of the card reader/writer. Turn the card reader/writer on and off.

(Default setting: ON)

Set it to ON if you want to activate card reader/writer, and to OUT OF SERVICE or OFF if a malfunction or other factor makes the card reader/writer unusable.

If you set this option to OUT OF SERVICE, the advertising loop (demo screen) will display the message, "The F-ZERO LICENSE CARD can not be used or purchased at this time," and users will be unable to play with license cards.

If you set this option to OFF, no message regarding license cards will be shown during the advertising loop.

### **MEMORY CARD SLOT USE**

Configure Nintendo GameCube Memory Card usage. This option lets you enable or disable the memory card slot. (Default setting: ON).

- Set this option to ON to enable compatibility with F-ZERO GX for the Nintendo GameCube. Note that this option cannot be used if the player does not have F-ZERO GX game data. Please set this option to OUT OF SERVICE or OFF until F-ZERO GX is released.
- If you set this option to OUT OF SERVICE, the advertising loop will display the message, "Can not use Nintendo GameCube Memory Card."
- If you set this option to OFF, no message regarding the Memory Card will be shown during the advertising loop.

#### **NOTES:**

- ◇ If both license cards and memory cards are set to OUT OF SERVICE, the advertising loop will display the message, "Cards cannot be used."
- ◇ If both are set to OFF, no message will be shown.
- ◇ If one of the two is set to OUT OF SERVICE, the message specific to that card will be shown.
- ◇ If one is set to OUT OF SERVICE and the other to OFF, no card instructions will be shown during the advertising loop.

### **GAME DIFFICULTY**

Set the game's difficulty level to five settings: VERY EASY, EASY, NORMAL, HARD, and HARDEST. (Default setting: NORMAL)

This changes the amount of bonus time given at checkpoints and the speed of COM machines (Race Mode only).

### **HANDICAP**

Turns the Race Mode (COM battles, player battles) handicap ON or OFF. (Default setting: ON).

### **VS BATTLE MODE**

Sets COM machine participation in Race Mode ON or OFF. (Default setting: OFF)

When set to ON, players race only against other players.

However, note that COM machines will join in Single Mode and Play Solo Even when in Linked Mode.

### **PASSWORD DISP**

Turn password display during Time Attack Mode ON and OFF. When set to ON, the password screen is shown after racing in Time Attack Mode. This password lets users join the F-ZERO Internet Rankings via their home computers. Please set this to OFF if Internet Rankings are not being listed. The launch of Internet Rankings will be announced on the Official F-ZERO Home Page, <http://f-zero.jp/>. (Default setting: ON)

### **RACE MODE LAPS**

In Race Mode, there are six setting levels for the number of laps; Normal and Settings 1 to 5. (Default setting: NORMAL). The game features six courses, and the number to the left of each course is its number of laps. The number of laps in Time Attack Mode cannot be changed.

Changes to settings are not enabled until Test Mode is exited. After changing settings, be sure to exit Test Mode.

After changing the settings, select EXIT and press the TEST Button to return to the Game Test Menu screen.

### 5.2.10.5. Network Settings

Select NETWORK SETTING to display the following screen and configure linked play settings.

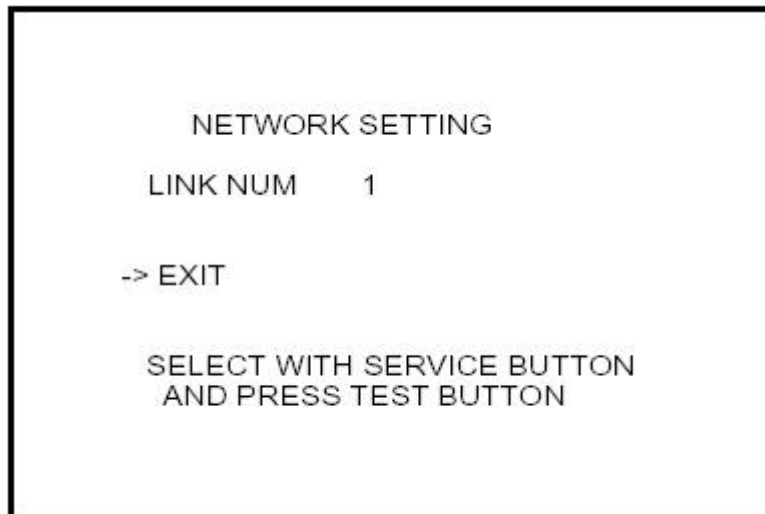
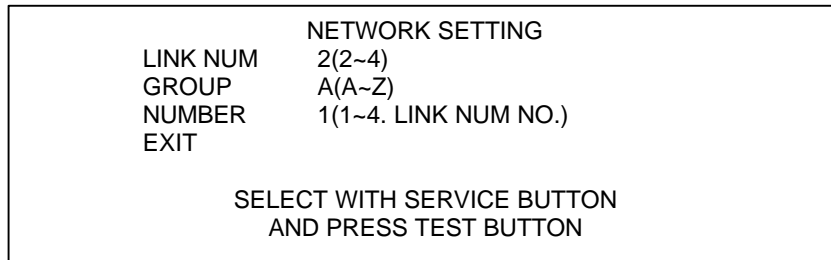

Press the SERVICE Button and move the cursor to select an option to change. Press the TEST Button to cycle through the settings shown to the left of the item.

#### **LINK NUM**

Set the number of game machines to link. Set this to "1" for the single setting. "2" or more allows linked play. You will need to set up groups and configure the NUMBER to enable linked play.

#### **GROUP**

Used to set groups among the linked machines. For instance, if four machines are connected and you want two groups of two, set two to "A" and the other two to "B." Ensure that you always have a group "A".

#### **NUMBER**

Assigns a number for each machine within a group. Do not use the same number twice in one group. Also note that you must set one machine as "1."

Changing the GAME DIFFICULTY, HANDICAP, VS BATTLE MODE, PASSWORD DISP, and RACE MODE LAPS settings of the "1" machine will automatically change the settings of machines numbered "2" to "4."

After changing the settings, select EXIT and press the TEST Button to return to the Game Test Menu screen.



### 5.2.10.6.Card Test

Test the functionality of or clean the card read/writer. The card read/writer should be tested and cleaned periodically.



- Clean the card reader/writer periodically.
- Set the TRIFORCE's internal clock to the correct time (see Section 5.2.8). If the internal clock is not set to the correct time, card play may be turned off at a different time from the one intended.

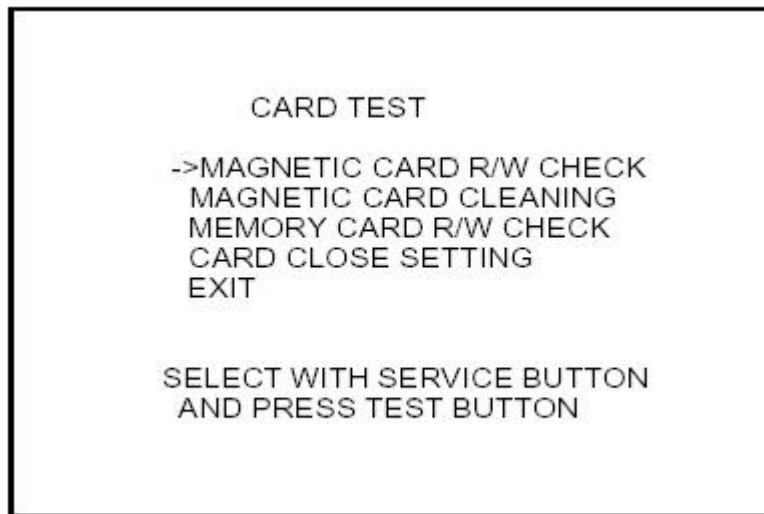

#### **MAGNETIC CARD R/W CHECK**

Checks the card reader/writer.

When checking, the message "Checking the card reader/writer" is shown and a read test, write test, and print test are automatically performed. Checking uses up one magnetic card.

If the test is completed without an error, the machine dispenses the card from the card reader/writer slot and posts a message asking you to remove the card. When the card has been taken, the screen reads "Succeeded to read/write."

If an error occurs, the screen produces an error display (see 18-1). If the error persists, try cleaning the read/write heads.

#### **MAGNETIC CARD CLEANING**

This allows you to clean the card reader/writer head. For instructions on handling the cleaning card, see 3.9.3.2.

1. Select MAGNETIC CARD CLEANING and press the TEST Button. The message "Insert the CLEANING CARD." will appear on the screen.
2. Insert the cleaning card into the card slot.
3. When cleaning is complete, the cleaning card will be automatically ejected and the user will be instructed to "Retrieve the CLEANING CARD."
4. Remove the cleaning card and throw it away. When the card has been removed, the screen reads "Succeeded to cleaning."

## MEMORY CARD R/W CHECK

```
MEMORY CARD R/W CHECK

INSERT A MEMORY CARD WITH
AT LEAST 4 EMPTY BLOCKS.

WRITE:[-]
READ :[-]

DO NOT INSERT THE MEMORY CARD WITH AN
IMPORTANT DATA. IT CAN GET DAMAGED.

EXIT:TEST BUTTON
```

This checks the Memory Card slot. To perform the check, you will need a Nintendo GameCube Memory Card with four blocks of free space.

Note that there is a chance of data loss. Do not use a Memory Card that contains important information.

```
MEMORY CARD R/W CHECK

NOW CHECKING- (SUCCEEDED TO READ/WRITE OR FAILED TO READ/WRITE)

WRITE:  [--]
READ:   [--]

DO NOT INSERT THE MEMORY CARD WITH AN IMPORTANT DATA. IT CAN BE DAMAGED

EXIT:   TEST BUTTON
```

Insert the Memory Card to automatically begin reading and writing tests.  
Re-insertion is directed when the Card is already inserted.

If all goes well, "NOW CHECKING..." will switch to "SUCCEEDED TO READ/WRITE." and a circle [O] will appear by each item.

If there is a problem, the message "FAILED TO READ/WRITE" will appear and an "X" will be displayed by each item.

If the "X" continues to appear after repeated tests with different memory cards, check the wiring. If you cannot find anything wrong with the wiring, you will need to replace the Memory Card slot.

## Card Close Setting



- Users will be unable to use their cards during the time(s) that you set. Be sure to set the appropriate time(s) based on the circumstances.

This allows you to assign the "card close" times. Players will not be able to use their cards from the time that you set; cards will remain unusable until the power is reset.

Be sure to set the appropriate time given the circumstances. For instance, if you close at midnight, try setting the time to fifteen minutes before closing, at 11:45.

If you have set RACE MODE LAPS to SET5, the large number of laps may take some time to complete, so 30 minutes before closing time (11:30) might be more appropriate.

There are three ways to set the "card close": WEEK, DAY, and OFF. Set the cursor to DAY and press the TEST Button to change the type.

### Day Time Settings

Use this to set the "card close" time to be the same every day. Configure in the same way as with WEEK. (The default setting is 23:45.)



### Weekly Time Settings

Set the "card close" time for each day. Press the SERVICE Button to select the day and the TEST Button to change the time. Times can be changed in fifteen-minute intervals. (The default setting is 0:45 for Friday, Saturday and Sunday, and 23:45 for other days.)

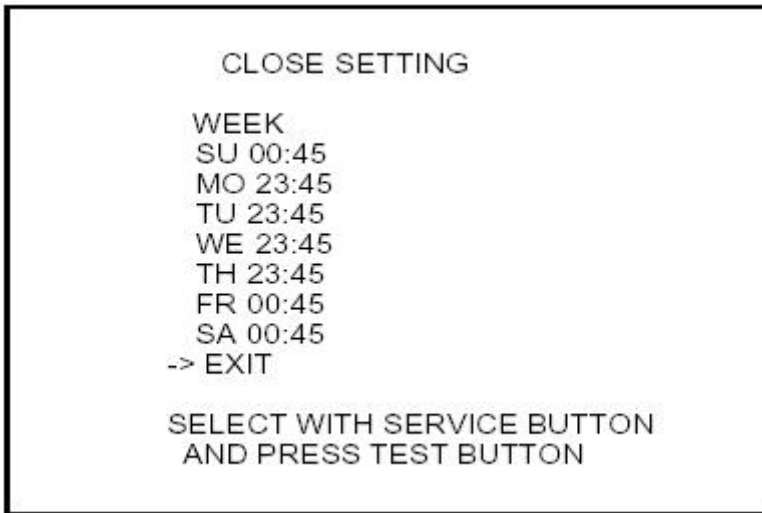

### The OFF Setting

Disable "card close" setting.

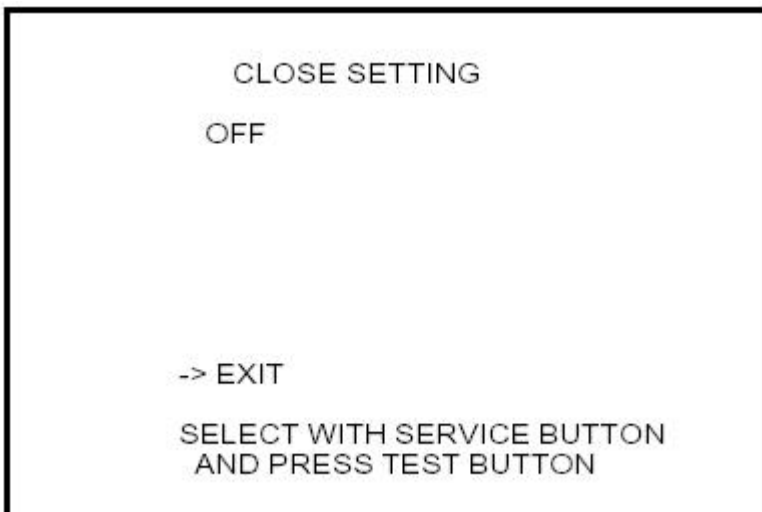

After changing the settings, select EXIT and press the TEST Button to return to the Game Test Menu screen.

### 5.2.10.7. Calibration



- To calibrate the input devices, be sure to move them to their maximum extent. The input devices will not be calibrated unless the number displayed exceeds "10".

Calibration adjusts the controls to eliminate inconsistencies.

PULL/PUSH HANDLE LEFT/RIGHT HANDLE AND STEP PEDALS	
STEERING PULLING	0(~255)
STEERING PUSHING	0(~255)
STEERING LEFT	0(~255)
STEERING RIGHT	0(~255)
GAS	0(~255)
BRAKE	0(~255)
PRESS TEST BUTTON TO CANCEL	

This calibrates the input magnitudes for the steering wheel, accelerator (GAS), and brake. To calibrate the steering wheel, move the handle all the way up, down, right and left, and press the pedal all the way down. The adjustments made to the values with this program are reflected in the game's controls.

After the input devices have been moved and their input values adjusted, the screen display will change from "PRESS TEST BUTTON TO CANCEL" to "PRESS TEST BUTTON TO EXIT". Press the TEST Button to return to the menu screen; the input devices will be calibrated to reflect the input values.

If the TEST Button is pressed while the screen displays "PRESS TEST BUTTON TO CANCEL", the input devices will not be calibrated.

Press the TEST Button to return to the Game Test Menu screen.

## Race Record

Select RACE RECORD to display the twelve screens of play data.

Press the TEST Button to cycle through each screen from (1/12) to (12/12). Pressing the TEST Button while the (12/12) screen is displayed returns you to the Game Test

RACE RECORD 1/12	
NUMBER OF GAMES	00
LICENSE CARD PLAY	00
LICENSE CARD BUY	00
MEMCARD PLAY	00
LINK VS PLAY	00
PRESS TEST BUTTON TO CONTINUE	

- **NUMBER OF GAMES:** Total number of games
- **LICENSE CARD PLAY:** Number of times license cards have been used
- **LICENSE CARD BUY:** Number of license cards sold
- **MEMCARD PLAY:** Number of times players have played using the Memory Card
- **LINK VS PLAY:** Number of times link play has been played

RACE RECORD 2/12					
MACHINE DATA					
Machine	Play	Col 1	Col 2	Col 3	Col 4
ORIGINAL	0	0	0	0	0
BFALCON	0	0	0	0	0
GFOX	0	0	0	0	0
WGOOSE	0	0	0	0	0
FSTING	0	0	0	0	0
RAINP	0	0	0	0	0
SMOON	0	0	0	0	0
RTURTLE	0	0	0	0	0
CDOLPHIN	0	0	0	0	0
SRAT	0	0	0	0	0
PINKS	0	0	0	0	0
BFLASH	0	0	0	0	0
MGULL	0	0	0	0	0
GTAXI	0	0	0	0	0
FATS	0	0	0	0	0
PRESS TEST BUTTON TO CONTINUE					

Shows the machines and colors chosen by the players.

RACE RECORD 3/12

VS COURSE DATA

Course	Play	Runall	destroy		courseout		burst	
			AVG	MAX	AVG	MAX	AVG	MAX
1	0	0	0.0	0	0.0	0	0.0	0
2	0	0	0.0	0	0.0	0	0.0	0
3	0	0	0.0	0	0.0	0	0.0	0
4	0	0	0.0	0	0.0	0	0.0	0
5	0	0	0.0	0	0.0	0	0.0	0
6	0	0	0.0	0	0.0	0	0.0	0

PRESS TEST BUTTON TO CONTINUE

Race Mode play data by course.

- Course: Course number
- Play: Times played
- Runall: Number of times completed
- destroy: Number of rival cars which have been destroyed in a single game (shows average and maximum)
- courseout: Number of times the player has run off course in a single game (shows average and maximum)
- burst: Number of times the player's machine has been destroyed in a single game (shows average and maximum)

RACE RECORD 4/12

VS COURSE RANK DATA

COURSE	1	2	3	4	5	6
RANK 1	0	0	0	0	0	0
RANK 2	0	0	0	0	0	0
RANK 3	0	0	0	0	0	0
RANK 4	0	0	0	0	0	0
RANK 5	0	0	0	0	0	0
RANK 6	0	0	0	0	0	0
RANK 7	0	0	0	0	0	0
RANK 8	0	0	0	0	0	0
RANK 9	0	0	0	0	0	0
RANK 10	0	0	0	0	0	0
RANK 11	0	0	0	0	0	0
RANK 12	0	0	0	0	0	0
RANK 13	0	0	0	0	0	0
RANK 14	0	0	0	0	0	0
RANK 15	0	0	0	0	0	0
RANK 16	0	0	0	0	0	0
RANK 17	0	0	0	0	0	0
RANK 18	0	0	0	0	0	0
RANK 19	0	0	0	0	0	0
RANK 20	0	0	0	0	0	0
RANK 21	0	0	0	0	0	0
RANK 22	0	0	0	0	0	0
RANK 23	0	0	0	0	0	0
RANK 24	0	0	0	0	0	0
RANK 25	0	0	0	0	0	0
RANK 26	0	0	0	0	0	0
RANK 27	0	0	0	0	0	0
RANK 28	0	0	0	0	0	0
RANK 29	0	0	0	0	0	0
RANK 30	0	0	0	0	0	0

PRESS TEST BUTTON TO CONTINUE

Shows rank information by course for Race Mode.

RACE RECORD 5/12 ~10/12)

TIME ATTACK COURSE 1 (1~6) DATA

play num : 0  
all run num : 0  
courseout avg : 0.0 max : 0  
burst avg : 0.0 max : 0

Machine	fastest time	fastest lap
ORIGINAL	0'00"000	0'00"000
BFALCON	0'00"000	0'00"000
GFOX	0'00"000	0'00"000
WGOOSE	0'00"000	0'00"000
FSTING	0'00"000	0'00"000
RAINP	0'00"000	0'00"000
SMOON	0'00"000	0'00"000
RTURTLE	0'00"000	0'00"000
CDOLPHIN	0'00"000	0'00"000
SRAT	0'00"000	0'00"000
PINKS	0'00"000	0'00"000
BFLASH	0'00"000	0'00"000
MGULL	0'00"000	0'00"000
GTAXI	0'00"000	0'00"000
FATS	0'00"000	0'00"000

PRESS TEST BUTTON TO CONTINUE

This is play data by course for Time Attack Mode. Course-specific information is shown on screens (5/12) through (10/12). Press the TEST Button to change the screen (the number "X" will change in the TIME ATTACK COURSE "X" DATA title).

- play num: The number of times each course has been played
- all run num: The number of times races have been completed
- courseout: The number of times players have run off the course (shows average and maximum)
- burst: The number of times machines have exploded (shows average and maximum)



RACE RECORD 11/12

GARAGE GET PARTS

NAME	BUY/DISP	RATE
Brave Eagle	0/0	0%
Giant Planet	0/0	0%
Megalo Cruiser	0/0	0%
Splash Whale	0/0	0%
Wild Chariot	0/0	0%
Holy Spider	0/0	0%
Optical Wing	0/0	0%
Dread Hammer	0/0	0%
Silver Sword	0/0	0%
Space Cancer	0/0	0%
Wonder Worm	0/0	0%
Combat Cannon	0/0	0%
Cyber Fox	0/0	0%
Heat Snake	0/0	0%
Rave Drifter	0/0	0%
Spark Bird	0/0	0%
Dank Chaser	0/0	0%
Crystal Egg	0/0	0%
Red Rex	0/0	0%
Sonic Soldier	0/0	0%
Euros-01	0/0	0%
Triangle-GT	0/0	0%
Bluster-X	0/0	0%
Devilfish-RX	0/0	0%
Extreme-ZZ	0/0	0%
Punisher-4X	0/0	0%
Impulse 220	0/0	0%
Meteor-RR	0/0	0%
Jupiter-Q	0/0	0%
Comet-V	0/0	0%

PRESS TEST BUTTON TO CONTINUE

Shows information regarding parts swapped in the Configuration Screen. The denominator is the number of times the part has appeared, and the numerator is the number of times it has been acquired.

RACE RECORD 12/12

PILOT POINT

COURSE	AVG POINT	MAX POINT	MIN POINT
1	000	0000	100
2	000	0000	100
3	000	0000	100
4	000	0000	100
5	000	0000	100
6	000	0000	100

PRESS TEST BUTTON TO EXIT

Shows pilot points earned by course.

### 5.2.10.8.Bookkeeping

Select BOOKKEEPING to display three screens of operating status data. Press the TEST Button to cycle through each screen from (1/3) to (3/3). Pressing the TEST Button while the (3/3) screen is displayed returns you to the Game Test Menu.

BOOKKEEPING 1/3	
COIN CHUTE 1	0
COIN CHUTE 2	0
TOTAL COINS	0
COIN CREDITS	0
SERVICE CREDITS	00
TOTAL CREDITS	00
PRESS TEST BUTTON TO CONTINUE	

- COIN CHUTE 1: Number of coins inserted into Coin Slot 1.
- COIN CHUTE 2: Number of coins inserted into Coin Slot 2.
- TOTAL COINS: Total number of coins inserted into the coin slots.
  
- COIN CREDITS: Number of credits for the coins inserted.
- SERVICE CREDITS: Number of credits input by the SERVICE Button.
- TOTAL CREDITS: Total credits from coins and the SERVICE Button.

BOOKKEEPING 2/3	
NUMBER OF GAMES	00
TOTAL TIME	0D 00H 00M 00S
PLAY TIME	00H 00M 00S
AVERAGE PLAY TIME	00M 00S
LONGEST PLAY TIME	00H 00M 00S
SHORTEST PLAYTIME	00M 00S
PRESS TEST BUTTON TO CONTINUE	

- NUMBER OF GAMES: Total number of games played
- TOTAL TIME: Powered-up time (length of time the machine has been on)
- PLAY TIME: Total playing time
- AVERAGE PLAY TIME: Average game play time
- LONGEST PLAY TIME: Longest game play time
- SHORTEST PLAY TIME: Shortest game play time

BOOKKEEPING 3/3

TIME HISTOGRAM

0M00S ~ 0M29S	00
0M30S ~ 0M59S	00
1M00S ~ 1M29S	00
1M30S ~ 1M59S	00
2M00S ~ 2M29S	00
2M30S ~ 2M59S	00
3M00S ~ 3M29S	00
3M30S ~ 3M59S	00
4M00S ~ 4M29S	00
4M30S ~ 4M59S	00
5M00S ~ 5M29S	00
5M30S ~ 5M59S	00
6M00S ~ 6M29S	00
6M30S ~ 6M59S	00
OVER 7M00S	00

PRESS TEST BUTTON TO EXIT

TIME HISTOGRAM shows the number of plays and the respective play times.  
This histogram should be referred to when setting the Game Difficulty.

### 5.2.11.Backup Data Clear

Delete all BOOKKEEPING screen data. Use BACKUP DATA CLEAR in the SYSTEM TEST MODE to delete data about coin/credit collection.

Deleting this data does not affect the game settings or other data stored by the game.

Deleting this data will delete the data showing how many times the CARD R/W was used.

After deleting the data, the CARD R/W automatically enters Head Cleaning mode.

Refer to Section <7-2> Head Cleaning for more information about head cleaning.

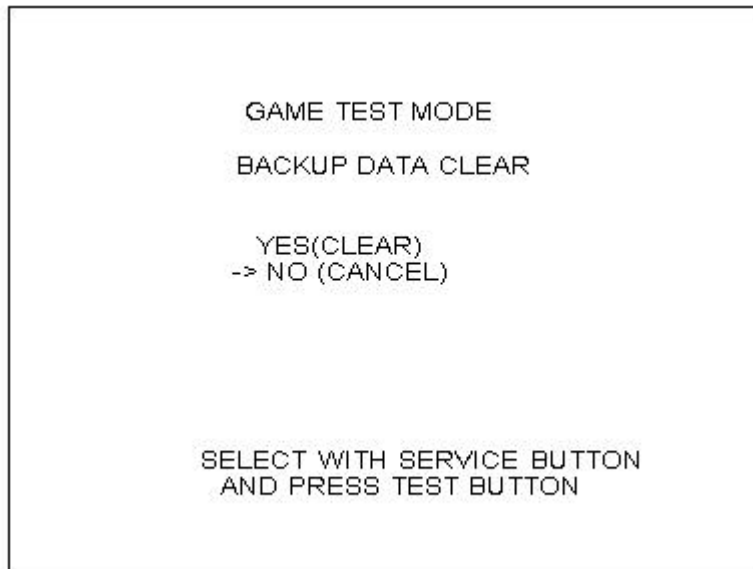

To clear data, use the SERVICE Button to move the cursor to YES (CLEAR) and then press the TEST Button. When the data has been cleared, the message "COMPLETED" will be displayed.

Press the TEST Button again to return to the Game Test Menu screen.

Move the cursor to NO (CANCEL) and press the TEST Button to return to the Game Test Menu screen without clearing the data.

## 6. COIN MECH INSTALLATION AND CREDIT BOARD SET UP

### 6.1. Introduction

Game credits between the Coin Mechanism and the game board for this machine are controlled by a VTS board. This electronic circuit allows the price of play to be set for a range of different countries. These functions are set on Dual In Line (DIL) PCB mounted switches.

SW1 is used to set the currency (or coin ratio) and SW3 the price of play. Refer to the Tables on the following pages for the correct settings for your environment.

The VTS board pictured below is mounted in the Coin Chute Tower.

The VTS board is connected to the coin validator and lamps via a dedicated wiring harness depending upon the coin validator used:

Wiring Harness	Validator	
LM1006	Coin Controls	(15 way connector)
LM1007	Mars	(13 way connector)
LM1008	Mechanical	See note 2
N/A	NRI	See note 1

#### Notes

1. If NRI mechanisms are to be used, these should be ordered with the highest denomination coin on coin path #1 and the lowest denomination on coin path #4. The VTS board should be then be set up for either the UK or Switzerland settings. A minimum connecting lead length of 600mm is required.
2. Mechanical coin mechanisms may be connected in parallel allowing two identical mechanisms to be fitted.

The VTS Board

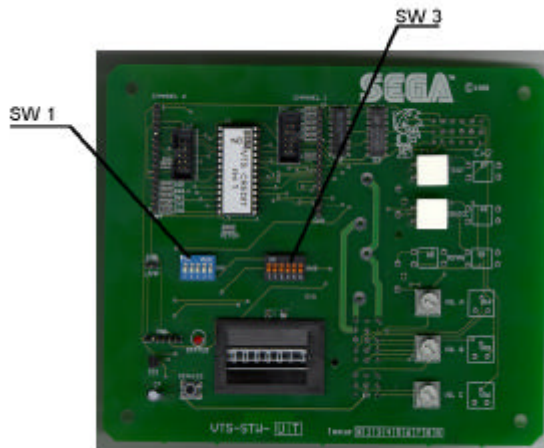

Credit Board Mode Settings Switch 3																				
Country	Setting	Switch 3 Setting					Coin Validator Programming										C120/SR3 Only			
		SW1	SW2	SW3	SW4	SW5	SW6	COIN1	COIN2	COIN3	COIN4	COIN5	COIN6	COIN7	COIN8	COIN9	COIN10	COIN11	COIN12	
UK	Coin Controls C220 Parallel	OFF	OFF	OFF	OFF			£1	50p new	20p	10p	-	50p old	-	-					
UK	Coin Controls C220 Binary	ON	OFF	OFF	OFF			£1	50p new	20p	10p	-	50p old	-	£2					
UK	Coin Controls C220 Binary	OFF	ON	OFF	OFF			£1	50p new	20p	10p	-	£2	-	50p old					
UK	Coin Controls SR3 Parallel	ON	ON	OFF	OFF			£1	50p new	20p	10p	-	£2	-	50p old	-	-	-	-	
UK Euro	Coin Controls SR3 Parallel	OFF	OFF	ON	OFF			£2 €2	£1 €1	50p new 50¢	20p 20¢	10p 10¢	-	-	-	50p old	-	-	-	
UK	Mars ME/MS 111 Parallel	ON	OFF	ON	OFF			£1	£2	20p	10p	50p new	50p old							
UK	NRI Parallel	OFF	ON	ON	OFF			10p	20p	50p	£1	£2	-							
Belgium	Parallel	ON	ON	ON	OFF			-	50Bfr	20Bfr	5Bfr									
Holland	Parallel	OFF	OFF	OFF	ON			-	5NLG	2.5NLG	1NLG									
Austria	SR3 Parallel	ON	OFF	OFF	ON			20Sch	10Sch	5Sch	1Sch									
Spain	Coin Controls C220 Binary	OFF	ON	OFF	ON			500Pta	200Pta	100Pta	50Pta	25Pta	200Pt old	50Pta old	25Pta old					
Spain	SR3/NRI Parallel	ON	ON	OFF	ON			500Pta	200Pta	100Pta	50Pta	25Pta	-	-	200Pta	-	50Pta old	25Pta old	-	
Spain	Coin Controls C220 Parallel	OFF	OFF	ON	ON			100Pta	50Pta new	-	25Pta new	-	50Pta old	-	25Pta old					
Portugal Euro	Parallel	ON	OFF	ON	ON			200Es €1	100Es 50¢	50Es	-	-	-	-	-					
	TBA					OFF		TBA					<b>Please Note</b> The credit board automatically sets the validator for parallel and binary operation through an output on pin 8 of the 17 way pinstrip. For the feature to work it is necessary for the validator interconnecting cable to include at wire at this position							
						ON		TBA												
	Channels						OFF	Direct Mode												
							ON	2 channel Mode												

Note: These switch settings are under constant review and may change due to world currency updates.

- Set SW 1 according to the option settings found in the relevant Price of Play Settings Table on the following pages.
- For Germany (DM), France (Fr) & Switzerland (SFr), use the appropriate existing setting shown above (from another country) that matches the coin ratios programmed into your coin meter.
- Set SW 3 on the VTS/Excel board as shown in the table above corresponding to the country required.

### 6.1.1. Price Of Play Settings UK

	Price	Bonus			DIL Switch 1				
					Switch 1	Switch 2	Switch 3	Switch 4	Switch 5
1	10p	No Bonus			OFF	OFF	OFF	OFF	OFF
2	10p	6 = 50p			<b>ON</b>	OFF	OFF	OFF	OFF
3	20p	No Bonus			OFF	<b>ON</b>	OFF	OFF	OFF
4	20p	3 = 50p	6 = £1	12 =£2	<b>ON</b>	<b>ON</b>	OFF	OFF	OFF
5	30p	No Bonus			OFF	OFF	<b>ON</b>	OFF	OFF
6	30p	1.66 = 50p	4 = £1	8 = £2	<b>ON</b>	OFF	<b>ON</b>	OFF	OFF
7	30p	2 = 50p	4 = £1		OFF	<b>ON</b>	<b>ON</b>	OFF	OFF
8	30p	AMLD *	3 = £1	6 = £2	<b>ON</b>	<b>ON</b>	<b>ON</b>	OFF	OFF
9	40p	No Bonus			OFF	OFF	OFF	<b>ON</b>	OFF
10	40p	1.25 = 50p	3 = £1	6 = £2	<b>ON</b>	OFF	OFF	<b>ON</b>	OFF
11	50p	No Bonus			OFF	<b>ON</b>	OFF	<b>ON</b>	OFF
12	50p		3 = £1	6 = £2	<b>ON</b>	<b>ON</b>	OFF	<b>ON</b>	OFF
13	50p		2 = £1	5 = £2	OFF	OFF	<b>ON</b>	<b>ON</b>	OFF
14	60p	No Bonus			<b>ON</b>	OFF	<b>ON</b>	<b>ON</b>	OFF
15	60p		2 = £1	4 = £2	OFF	<b>ON</b>	<b>ON</b>	<b>ON</b>	OFF
16	80p	No Bonus			<b>ON</b>	<b>ON</b>	<b>ON</b>	<b>ON</b>	OFF
17	80p	1.25 = £1	2 = £1.50	2.5 = £2	OFF	OFF	OFF	OFF	<b>ON</b>
18	£1	No Bonus			<b>ON</b>	OFF	OFF	OFF	<b>ON</b>
19	£1		3 = £2		OFF	<b>ON</b>	OFF	OFF	<b>ON</b>
20	£1		2 = £2	5 = £4	<b>ON</b>	<b>ON</b>	OFF	OFF	<b>ON</b>
21	£1.50	No Bonus			OFF	OFF	<b>ON</b>	OFF	<b>ON</b>
22	£1.50		2 = £2		<b>ON</b>	OFF	<b>ON</b>	OFF	<b>ON</b>
23	£2	No Bonus			OFF	<b>ON</b>	<b>ON</b>	OFF	<b>ON</b>
24	£2			3 = £5	<b>ON</b>	<b>ON</b>	<b>ON</b>	OFF	<b>ON</b>
25	£3	No Bonus			OFF	OFF	OFF	<b>ON</b>	<b>ON</b>
26	£3			2 = £5	<b>ON</b>	OFF	OFF	<b>ON</b>	<b>ON</b>
27	£5	No Bonus			OFF	<b>ON</b>	OFF	<b>ON</b>	<b>ON</b>
28	£5			3 = £10	<b>ON</b>	<b>ON</b>	OFF	<b>ON</b>	<b>ON</b>
29	£7.50	No Bonus			OFF	OFF	<b>ON</b>	<b>ON</b>	<b>ON</b>
30	£7.50			2 = £10	<b>ON</b>	OFF	<b>ON</b>	<b>ON</b>	<b>ON</b>
31	£10	No Bonus			OFF	<b>ON</b>	<b>ON</b>	<b>ON</b>	<b>ON</b>
32	Free Play				<b>ON</b>	<b>ON</b>	<b>ON</b>	<b>ON</b>	<b>ON</b>

### 6.1.2. Price Of Play Settings Euro

	Price	Bonus			DIL Switch 1				
					Switch 1	Switch 2	Switch 3	Switch 4	Switch 5
1	10¢	No Bonus			OFF	OFF	OFF	OFF	OFF
2	10¢	6 = 50¢			<b>ON</b>	OFF	OFF	OFF	OFF
3	20¢	No Bonus			OFF	<b>ON</b>	OFF	OFF	OFF
4	20¢	3 = 50¢	6 = €1	12 = €2	<b>ON</b>	<b>ON</b>	OFF	OFF	OFF
5	30¢	No Bonus			OFF	OFF	<b>ON</b>	OFF	OFF
6	30¢	1.66 = 50¢	4 = €1	8 = €2	<b>ON</b>	OFF	<b>ON</b>	OFF	OFF
7	30¢	2 = 50¢	4 = €1		OFF	<b>ON</b>	<b>ON</b>	OFF	OFF
8	30¢	AMLD *	3 = €1	6 = €2	<b>ON</b>	<b>ON</b>	<b>ON</b>	OFF	OFF
9	40¢	No Bonus			OFF	OFF	OFF	<b>ON</b>	OFF
10	40¢	1.25 = 50¢	3 = €1	6 = €2	<b>ON</b>	OFF	OFF	<b>ON</b>	OFF
11	50¢	No Bonus			OFF	<b>ON</b>	OFF	<b>ON</b>	OFF
12	50¢		3 = €1	6 = €2	<b>ON</b>	<b>ON</b>	OFF	<b>ON</b>	OFF
13	50¢		2 = €1	5 = €2	OFF	OFF	<b>ON</b>	<b>ON</b>	OFF
14	60¢	No Bonus			<b>ON</b>	OFF	<b>ON</b>	<b>ON</b>	OFF
15	60¢		2 = €1	4 = €2	OFF	<b>ON</b>	<b>ON</b>	<b>ON</b>	OFF
16	80¢	No Bonus			<b>ON</b>	<b>ON</b>	<b>ON</b>	<b>ON</b>	OFF
17	80¢	1.25 = £1	2 = €1.50	2.5 = €2	OFF	OFF	OFF	OFF	<b>ON</b>
18	€1	No Bonus			<b>ON</b>	OFF	OFF	OFF	<b>ON</b>
19	€1		3 = €2		OFF	<b>ON</b>	OFF	OFF	<b>ON</b>
20	€1		2 = €2	5 = €4	<b>ON</b>	<b>ON</b>	OFF	OFF	<b>ON</b>
21	€1.50	No Bonus			OFF	OFF	<b>ON</b>	OFF	<b>ON</b>
22	€1.50		2 = €2		<b>ON</b>	OFF	<b>ON</b>	OFF	<b>ON</b>
23	€2	No Bonus			OFF	<b>ON</b>	<b>ON</b>	OFF	<b>ON</b>
24	€2			3 = €5	<b>ON</b>	<b>ON</b>	<b>ON</b>	OFF	<b>ON</b>
25	€3	No Bonus			OFF	OFF	OFF	<b>ON</b>	<b>ON</b>
26	€3			2 = €5	<b>ON</b>	OFF	OFF	<b>ON</b>	<b>ON</b>
27	€5	No Bonus			OFF	<b>ON</b>	OFF	<b>ON</b>	<b>ON</b>
28	€5			3 = €10	<b>ON</b>	<b>ON</b>	OFF	<b>ON</b>	<b>ON</b>
29	€7.50	No Bonus			OFF	OFF	<b>ON</b>	<b>ON</b>	<b>ON</b>
30	€7.50			2 = €10	<b>ON</b>	OFF	<b>ON</b>	<b>ON</b>	<b>ON</b>
31	€10	No Bonus			OFF	<b>ON</b>	<b>ON</b>	<b>ON</b>	<b>ON</b>
32	Free Play				<b>ON</b>	<b>ON</b>	<b>ON</b>	<b>ON</b>	<b>ON</b>



6.1.3. Price Of Play Settings Austria-Czech-Denmark-Norway-Israel-France2

	Price	Bonus			Switch 1				
					Switch 1	Switch 2	Switch 3	Switch 4	Switch 5
1	1	No Bonus			OFF	OFF	OFF	OFF	OFF
2	1			11 = 10	<b>ON</b>	OFF	OFF	OFF	OFF
3	1		6 = 5		OFF	<b>ON</b>	OFF	OFF	OFF
4	2	No Bonus			<b>ON</b>	<b>ON</b>	OFF	OFF	OFF
5	2			6 = 10	OFF	OFF	<b>ON</b>	OFF	OFF
6	2		3 = 5		<b>ON</b>	OFF	<b>ON</b>	OFF	OFF
7	3	No Bonus			OFF	<b>ON</b>	<b>ON</b>	OFF	OFF
8	3			4 = 10	<b>ON</b>	<b>ON</b>	<b>ON</b>	OFF	OFF
9	3		2 = 5		OFF	OFF	OFF	<b>ON</b>	OFF
10	4	No Bonus			<b>ON</b>	OFF	OFF	<b>ON</b>	OFF
11	4		3 = 10		OFF	<b>ON</b>	OFF	<b>ON</b>	OFF
12	5	No Bonus			<b>ON</b>	<b>ON</b>	OFF	<b>ON</b>	OFF
13	5			3 = 10	OFF	OFF	<b>ON</b>	<b>ON</b>	OFF
14	6	No Bonus			<b>ON</b>	OFF	<b>ON</b>	<b>ON</b>	OFF
15	6			4 = 20	OFF	<b>ON</b>	<b>ON</b>	<b>ON</b>	OFF
16	8	No Bonus			<b>ON</b>	<b>ON</b>	<b>ON</b>	<b>ON</b>	OFF
17	10	No Bonus			OFF	OFF	OFF	OFF	<b>ON</b>
18	10			3 = 20	<b>ON</b>	OFF	OFF	OFF	<b>ON</b>
19	20	No Bonus			OFF	<b>ON</b>	OFF	OFF	<b>ON</b>
20	20			3 = 50	<b>ON</b>	<b>ON</b>	OFF	OFF	<b>ON</b>
21	30	No Bonus			OFF	OFF	<b>ON</b>	OFF	<b>ON</b>
22	30			2 = 50	<b>ON</b>	OFF	<b>ON</b>	OFF	<b>ON</b>
23	50	No Bonus			OFF	<b>ON</b>	<b>ON</b>	OFF	<b>ON</b>
24	50			3 = 100	<b>ON</b>	<b>ON</b>	<b>ON</b>	OFF	<b>ON</b>
32	Free Play				<b>ON</b>	<b>ON</b>	<b>ON</b>	<b>ON</b>	<b>ON</b>

## 7. DESIGN RELATED PARTS

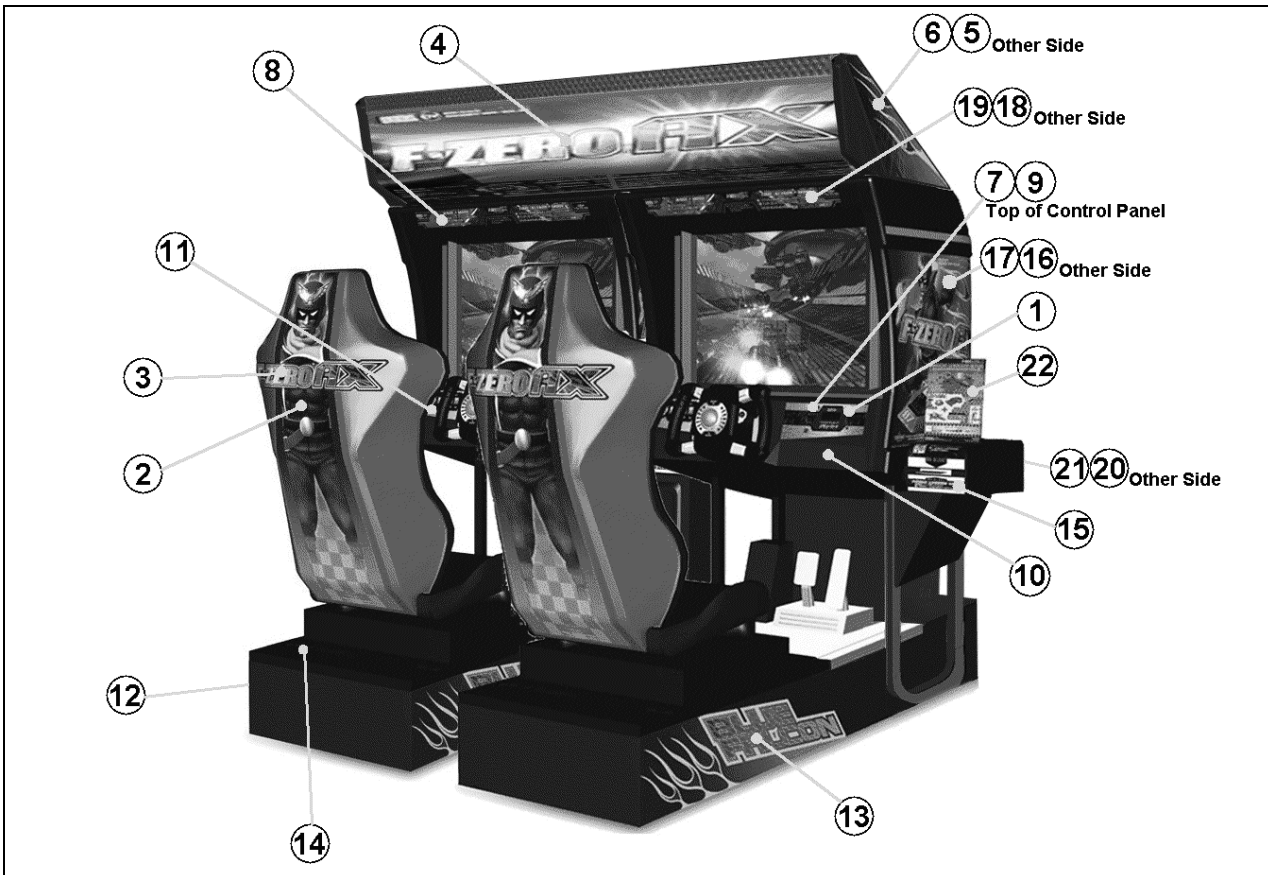

ITEM	PART NO,	DESCRIPTION
1	FZR-2162UK	STICKER MEMORY SLOT
2	FZR-1601-BUK	STICKER SEAT BACK
3	FZR-1601-CUK	STICKER SEAT BACK LOGO
4	FZR-0215UK	BILLBOARD PLATE FZR TWIN
5	FZR-0202-BUK	STICKER SIDE COVER L
6	FZR-0203-BUK	STICKER SIDE COVER R
7	422-0911UK	PLAY INSTR FZR TWIN MULTI
8	422-0912UK	SUB INSTR FZR TWIN MULTI
9	FZR-1297UK	STICKER MEMORY CAUTION MULTI
10	FZR-2024UK	STICKER MEMORY SLOT LWR MULTI
11	FZR-2152	STICKER START VIEW
12	FZR-1501	STICKER BASE L
13	FZR-1502	STICKER BASE R
14	FZR-1503	STICKER BASE LID
15	FZR-0022-01	STICKER CARD SLOT FZR B ENG
16	FZR-1551-A	STICKER COVER PANEL L
17	FZR-1556-A	STICKER COVER PANEL R
18	FZR-1551-B	STICKER LINE L
19	FZR-1556-B	STICKER LINE R
20	FZR-1551-C	STICKER LOWER L
21	FZR-1556-C	STICKER LOWER R
22	FZR-0020UK	STICKER CARD SLOT FZR C MULTI

## 8. PARTS LIST

### 8.1. Assembly Structure

FZR-00001UK ~ TOP ASSY F-ZERO AX TWIN

FZR-10001UK (x2) ~ ASSY COCKPIT 1P

DUT-1120UK ~ ASSY SUB MAIN BASE

FZR-1550UK~ ASSY MONITOR COVER L 2P

APC-1560 ~ ASSY SPEAKER L

FZR-1555UK~ ASSY MONITOR COVER R 2P

APC-1565~ ASSY SPEAKER R

FZR-20001UK~ ASSY CONTROL PANEL STD

FZR-2500~ ASSY STEERING

FZR-2600~ ASSY HANDLE MECHA

FZR-2150UK~ ASSY START VIEW

FZR-2160UK ~ ASSY MEMORY SLOT

ORT-1100UK ~ ASSY PEDAL BASE ORT

SPG-2200 ~ ASSY BRAKE & ACCELL

FZR-1600UK~ ASSY SEAT TWIN 1P

FZR-4500UK ~ ASSY MAIN BD

FZR-4600UK ~ ASSY ELEC BD

FZR-1510UK~ ASSY BASE LID R

FZR-INST-TW ~ ASSY INST KIT FZR TWIN

FZR-0200UK~ ASSY BILLBOARD

FRI-0300UK~ ASSY COINCHUTE TOWER FRI

ORT-0500UK ~ ASSY WIRE COVER ORT TWIN

ORT-0400UK~ ASSY AC BRKT MAIN

ORT-0700UK ~ ASSY AC BRKT SUB

VOF-0450UK~ CARD UNIT TWIN L

VOF-0460UK ~ CARD UNIT TWIN R

## 8.2. FZR-0001UK TOP ASSY TWIN

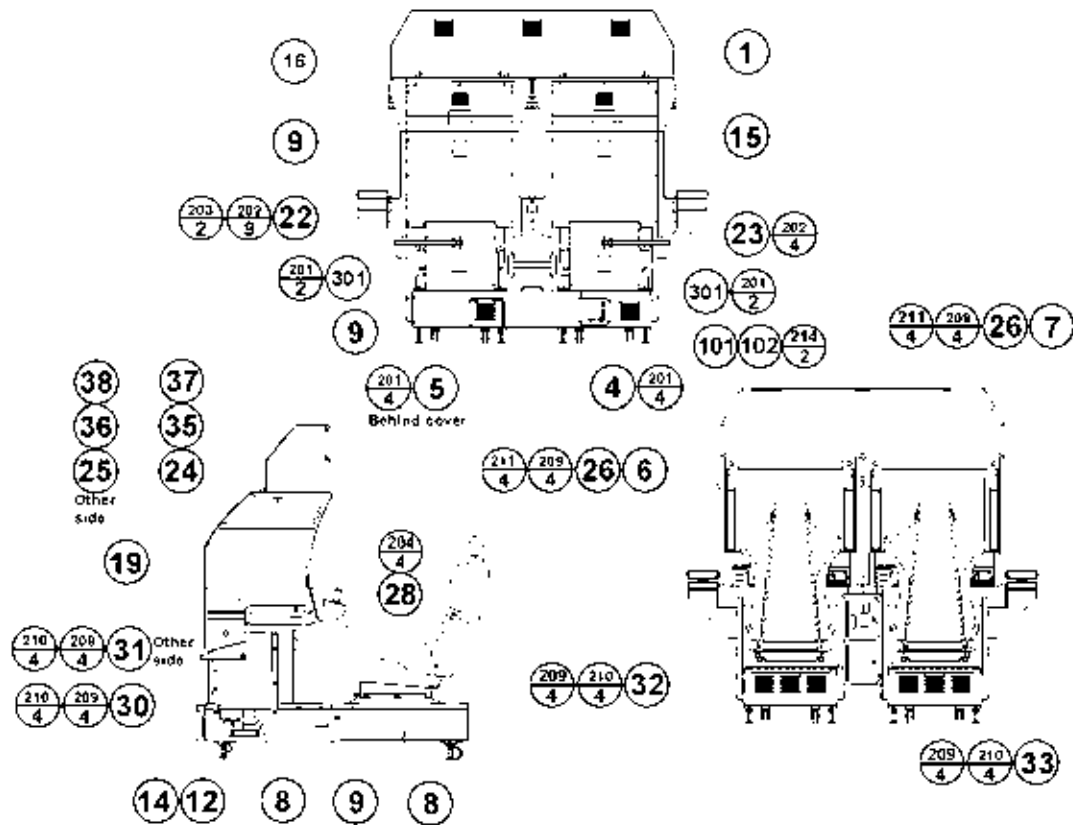

ITEM	PART NO.	QTY	DESCRIPTION	COMPONENT REF.
1	FZR-10001UK		ASSY COCKPIT 1P	
3	FZR-INST-TW		ASSY INSTALLATION KIT FZR TWIN	
4	ORT-0400UK		ASSY AC BRKT MAIN	
5	ORT-0700UK		ASSY AC BRKT SUB	
6	VOF-0450UK		CARD UNIT TWIN L	
7	VOF-0460UK		CARD UNIT TWIN R	
8	421-7020UK		STICKER CAUTION FORK	
9	LB1102		STICKER DANGEROUS VOLTAGE	BACK LIDS-4, REAR FLR-2
12	421-7987-FZR-T		STICKER ELEC SPEC FZR TW	MAIN CABI, LHS OF MAIN BASE
14	421-7988-91UK		STICKER SERIAL NUMBER UK	1P-1,2P-2,CCT INSIDE TOP DOR
15	421-8543UK		STICKER CABINET L UK	1P
16	421-8544UK		STICKER CABINET R UK	2P
18	SGM-3863	2	POLY COVER 1800X950X1700	
19	SDW-0001UK	12	BLIND CAP UK	1P CABI (LHS), 2P CABI (RHS)
22	INY-0004	2	BACK LID INY	
23	CKT-0001UK	2	BACK LID B W/HOLE UK	
24	FZR-1551-A	1	STICKER COVER PANEL L	
25	FZR-1556-A	1	STICKER COVER PANEL R	

Cont.

ITEM	PART NO.	QTY	DESCRIPTION	COMPONENT REF.
26	CKT-0015UK	2	STICKER CARD LOADING INSTR	
27	LB1046	1	LABEL TESTED FOR ELEC. SAFETY	
28	RAL-XXX-13UK	2	LOCK COVER UK	(R.FLOORS)-2
30	CKT-0004	1	SIDE PNL L	
31	CKT-0005	1	SIDE PNL R	
32	CKT-0006UK	1	CARD UNIT BASE L	
33	CKT-0007UK	1	CARD UNIT BASE R	
35	FZR-1551-B	1	STICKER LINE L	
36	FZR-1556-B	1	STICKER LINE R	
37	FZR-1551-C	1	STICKER LOWER L	
38	FZR-1556-C	1	STICKER LOWER R	
101	601-8956-01	1	EARTH OUTLET WK3001W	LEFT UNIT
102	601-11071-IS	1	SW HUB PCI FX-08IS	LEFT UNIT
201	000-P00412-WB	10	M4X12 MSCR PAN W/FS BLK	(4)-4,(5)-4,(301)-2
202	000-P00408-WB	26	M4X8 MSCR PAN W/FS BLK	(22)-18,(23)-8
203	010-P00412	4	M4X12 S-TITE PAN PAS	(22)-4
204	008-T00408-0C	16	M4X8 TMP PRF TH CRM	(28)-8,(F.FLOORS)-8
205	029-B00620-0B	4	M6X20 SKT BH BLK	(R.FLOORS)-4
206	060-S00600-0B	4	M6 WSHR SPR BLK	(R.FLOORS)-4
207	060-F00600-0B	4	M6 WSHR FORM A FLT BLK	(R.FLOORS)-4
209	030-000820-SB	24	M8X20 BLT W/S BLK	(6)-4, (7)-4, (30)-4, (31)-4, (32)-4, (33)-4
210	068-852216-0B	16	M8 WSHR 22OD FLT BLK	(30)-4, (31)-4, (32)-4, (33)-4
211	060-F00800	8	M8 WSHR FORM A FLT PAS	(6)-4, (7)-4
214	012-P03512-F	2	N6X1/2" S/TAP FLG PAS	(101)-2
301	CKT-61009UK	2	WH EXT CARD R/W C	
302	600-7269-0200	1	ASSY LAN CABLE 0200CM	
303	ORT-64001UK	1	WH POWER HUB	
304	600-7269-0500	1	ASSY LAN CABLE 0500CM	
401	PK0348	2	SLEEVE COCKPIT FZR TWIN	
402	PK0349	2	PALLET FZR	
403	PK0348-LID	2	LID FZR TWIN	
405	290241	2	C-BUFFER-MK2-UNIVERSAL	BANDING PROTECTION

### 8.3. FZR-10001UK ASSY COCKPIT 1P

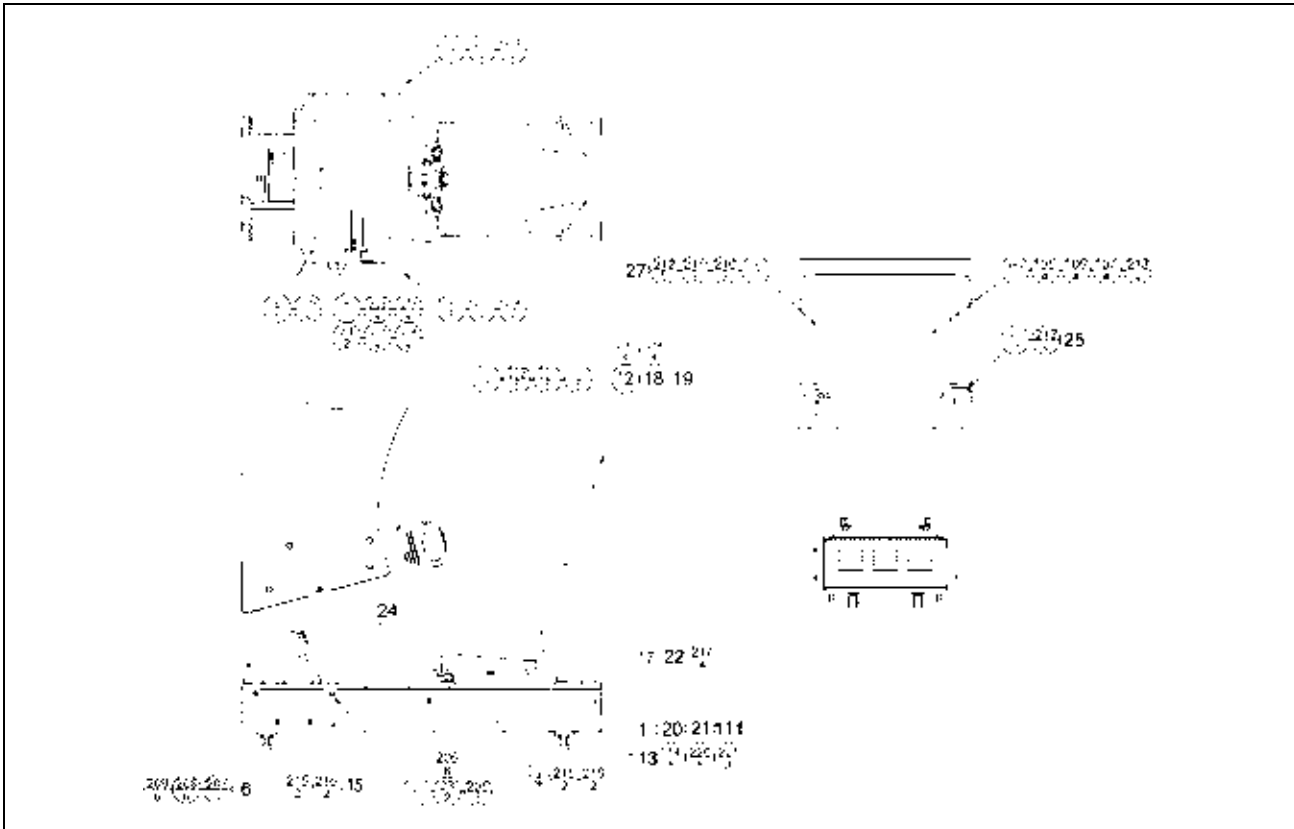

ITEM	PART NO.	QTY	DESCRIPTION	COMPONENT REF.
1	DUT-1120UK	1	ASSY SUB MAIN BASE	
2	FZR-1550UK	1	ASSY MONITOR COVER L 2P	
3	FZR-1555UK	1	ASSY MONITOR COVER R 2P	
4	FZR-20001UK	1	ASSY CONTROL PANEL STD	
5	POD-1023UK	1	MONITOR STAND	
6	ORT-1100UK	1	ASSY PEDAL BASE ORT	
7	POD-1021UK	1	MONITOR SUPPORT	
8	DUT-1008UK	1	ROOF LID DUT	
9	POD-1022	1	MONITOR MASK	
10	SPG-1005	1	MASK HOLDER	
12	FZR-1600UK	1	ASSY SEAT TWIN 1P	
14	FZR-4500UK	1	ASSY MAIN BD	
15	FZR-4600UK	1	ASSY ELEC BD	
17	FZR-1510UK	1	ASSY BASE LID R	
18	RAL-2007	1	RUBBER HOLDER R TWIN	(12)-1
19	RAL-2008		RUBBER HOLDER L TWIN	(12)-1
20	FZR-1501		STICKER BASE L	
21	FZR-1502		STICKER BASE R	
22	FZR-1503		STICKER BASE LID	(17)-1, CUT ENDS TO SUIT
23	POD-1026UK		CRT SPACER (POD)	(5)-2,(7)-2
24	DUT-2031UK		FRONT FLOOR UK DUT	FIX DOWN AT NEXT LEVEL UP
25	SRT-1009UK		MONITOR SPASHGUARD SRT TW	FIX TO (10)
26	SRT-2031UK		NEOPRENE RUBBER STRIP 10X3mm	(24)-0.5,(1)-0.4 4X10cm STRIPS
27	OS1004		DRAFT EXCLDR 4 X7MM BLK x 10M	(9)-705mm ON FRONT LIP
30	440-WS0220UK		WARNING STICKER TRAP HAZARD	
101	200-5949		ASSY CLR DSPL 29 TYPE 31K UK	

Cont.

ITEM	PART NO.	QTY	DESCRIPTION	COMPONENT REF.
105	280-5112	4	BUSH FOR TV	(101)-4
106	280-5113	4	COLLAR FOR TV	(101)-4
107	068-652516	4	M6 WSHR 25OD FLT PAS	(101)-4
108	280-L00716-OS	3	STANDOFF 7OD 4ID 16L	(101)-3 REMOTE BD
109	601-6231-C100	2	EDGING NEW TYPE	TOP OF WIRE COVER -2
110	601-6231-D100	2	EDGING NEW TYPE	INSIDE OF PEDAL BASE -2
111	260-0011-02	1	AXIAL FLOW FAN AC100V 50-60Hz	
112	440-WS0220UK	1	WARNING STICKER TRAP HAZARD	NEXT TO STEERING GEARS
113	FN1012	2	MESH GUARD METAL 120mm FAN	(111)-2
114	OS1195	8	RIVET SNAP MOSS SR1811	(113)-8
115	280-A00900-A	20	ROUTER TWIST D9 ADH	
116	280-A00748-PM	4	ROUTER TWIST D7 SO4.8PA	MONITOR STAND HORIZONTAL BAR
117	280-A02048-PM	12	ROUTER TWIST D20 SO4.8PA	WIRE COVER BOX 2X4 CORNER DROP
201	030-000840-SB	12	M8X40 BLT W/S BLK	(2)-4,(3)-4,(7)-4
202	008-B00825-0B	6	M8X25 TMP PRF BH BLK	(4)-6
203	060-S00800-0B	6	M8 WSHR SPR BLK	(4)-6
204	060-F00800-0B	18	M8 WSHR FORM A FLT BLK	(2)-4,(3)-4,(4)-6,(7)-4
205	030-000850-SB	8	M8X50 BLT W/S BLK	(5)-8
206	068-852216-0B	12	M8 WSHR 22OD FLT BLK	(5)-8,(12)-4
207	030-000616-SB	6	M6X16 BLT W/S BLK	(6)-6
208	068-651616-0B	6	M6 WSHR 16OD FLT BLK	(6)-6
209	000-P00408-WB	6	M4X8 MSCR PAN W/FS BLK	(8)-4,(6)-2
210	000-T00530-0B	2	M5X30 MSCR TH BLK	(9)-2
211	000-T00512-0B	3	M5X12 MSCR TH BLK	(9)-3
212	068-552016-0B	5	M5 WSHR 20OD FLT BLK	(9)-5
213	000-F00512	4	M5X12 MSCR CSK PAS	(10)-4
214	030-000820-SB	4	M8X20 BLT W/S BLK	(12)-4
215	032-000425	4	M4X25 W/BLT PAS	(14)-2,(15)-2
216	068-441616	4	M4 WSHR 16OD FLT PAS	(14)-2,(15)-2
217	008-T00512-0B	4	M5X12 TMP PRF TH BLK	(17)-4
218	050-F00600	4	M6 NUT FLG SER PAS	(101)-4
219	000-P00320	3	M3X20 MSCR PAN PAS	(101)-3 REMOTE BD
220	012-HB0512	8	N10X1/2" S/TAP HEX B PAS	(111)-8
221	060-F00500	8	M5 WSHR FORM A FLT PAS	(111)-8
301	TOF-60100UK	1	WH EXT VIEW BUTTON A	
302	FZR-61011UK	1	WH EXT MEM CARD A	
303	FZR-61012UK	1	WH EXT MEM CARD PWR A	
305	FZR-61006UK	1	WH EXT HANDLE A	
306	600-6373-77-91	1	WIRE HARNESS PLAYER SEL EXT B	
307	TOF-60101UK	1	WH EXT FRONT SP B	
308	FRI-61042UK	1	WIRE HARN EXT VR B	

Cont.

ITEM	PART NO.	QTY	DESCRIPTION	COMPONENT REF.
309	NCR-61011UK	1	WIRE HARN VIEW BUTTON B	
310	600-7009-2500	1	ASSY RGB CA D-SUB 15P 2500MM	
311	FZR-61007UK	1	WH EXT HANDLE B	
312	FRI-61041UK	1	WIRE HARN EXT MOTOR B	
313	FZR-61013UK	1	WH EXT MEM CARD B	
314	FZR-61014UK	1	WH EXT MEM CARD PWR B	
315	TOF-60052UK	1	WH EARTH FOR DRIVER MAIN BASE	
316	POD-61012UK	1	WIRE HARN 100V EXT COCKPIT	
317	TOF-60015UK	1	WH EXT ENCODER B	
318	NCR-61008UK	1	WH EXT FRONT SP A	
319	POD-61026UK	1	WIRE HARN EXT AC UNIT	
320	TOF-60103UK	1	WH VTS EXT	
321	TOF-60010UK	1	WH EXT CARD R/W A	
323	600-9020-44K	1	WIRE HARN EARTH 200mm M4/M4 K	MON STAND TO WIRE COVER BOX
324	600-9100-44K	2	WIRE HARN EARTH 1000mm M4/M4 K	MON STAND TO MON SUPPORT & C.PNL
325	600-9020-44K	1	WIRE HARN EARTH 200mm M4/M4 K	MON SPPORT TO ROOF LID
326	600-9060-46K	1	WIRE HARN EARTH 600mm M4/M6 K	MON STAND TO LH BOT OF 101



#### 8.4. DUT-1120UK ASSY SUB MAIN BASE

ITEM	PART NO.	QTY	DESCRIPTION	COMPONENT REF.
1	DUT-1121UK	1	MAIN BASE	
6	MA1007	4	CASTOR SWIVEL 63mm NYLON	
10	601-5699UK-01	2	LEG ADJ M16X100 1L/NUT	
11	601-5699UK-03	2	LEG ADJ M16X100 3 L/NUT	
209	030-000816	16	M8X16 BLT PAS	
210	060-S00800	16	M8 WSHR SPR PAS	

**8.5. FZR-1550 ASSY MONITOR COVER L 2P**

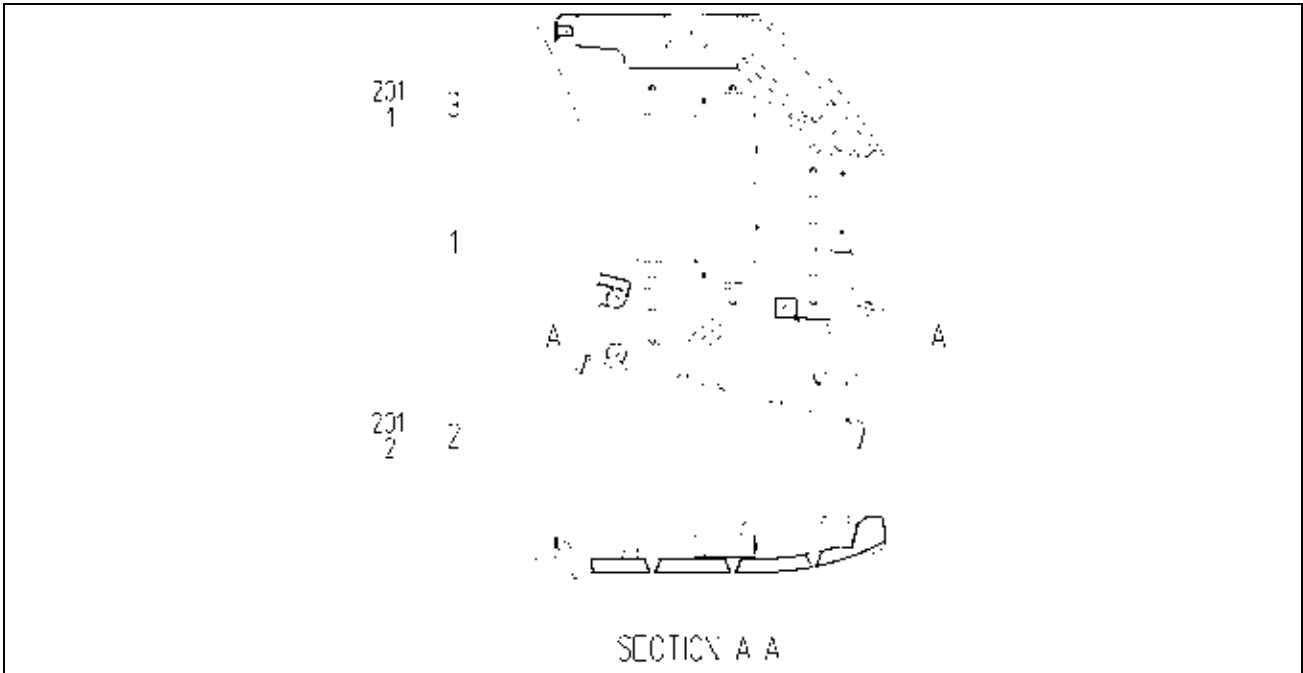

ITEM	PART NO.	QTY	DESCRIPTION	COMPONENT REF.
1	POD-1151X-A	1	COVER PANEL L BLANK	
2	APC-1560	1	ASSY SPEAKER L	
3	DYN-1032UK	1	MASK BRKT	
201	000-P00408-W	3	M SCR PH W/FS M4X8	(2)-2,(3)-1

**8.6. APC-1560 ASSY SPEAKER L**

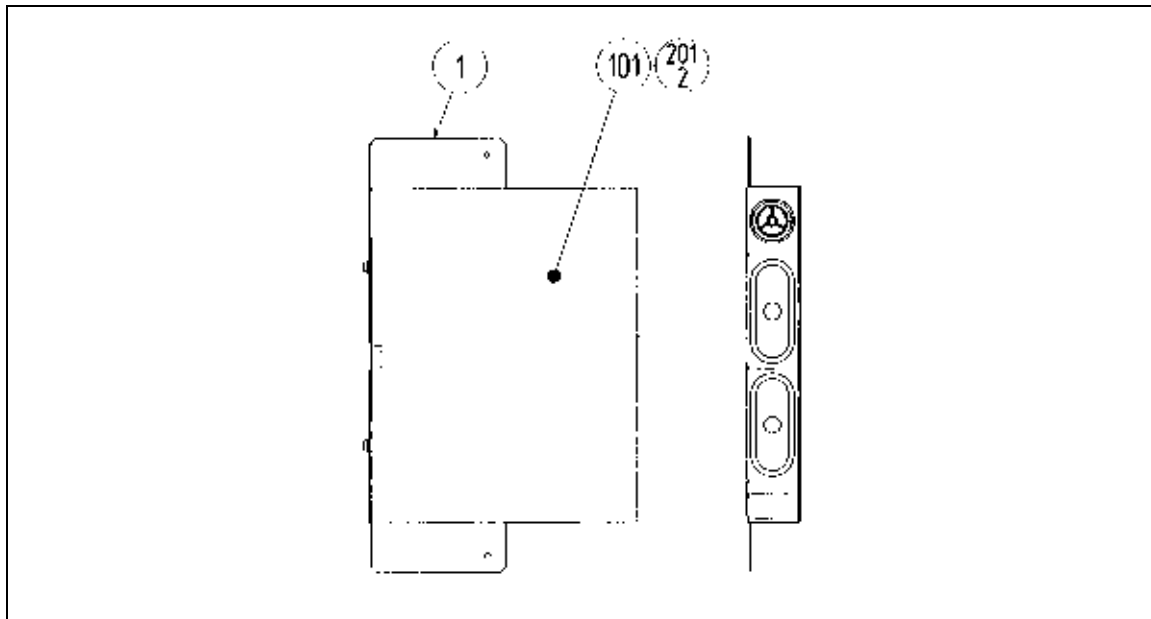

ITEM	PART NO.	QTY	DESCRIPTION	COMPONENT REF.
1	APC-1561	1	SPEAKER BRKT	
101	130-5156	1	SPEAKER BOX 8OHM 20W	TWEETER @ TOP
201	000-P00512-W	2	M SCR PH W/FS M5X12	(101)-2

**8.7. FZR-1555UK ASSY MONITOR COVER R 2P**



ITEM	PART NO.	QTY	DESCRIPTION	COMPONENT REF.
1	POD-1161X-A	1	COVER PANEL R BLANK	
2	APC-1565	1	ASSY SPEAKER R	
3	DYN-1032UK	1	MASK BRKT	
201	000-P00408-W	3	M SCR PH W/FS M4X8	(2)-2,(3)-1

**8.8. APC-1565 ASSY SPEAKER R**

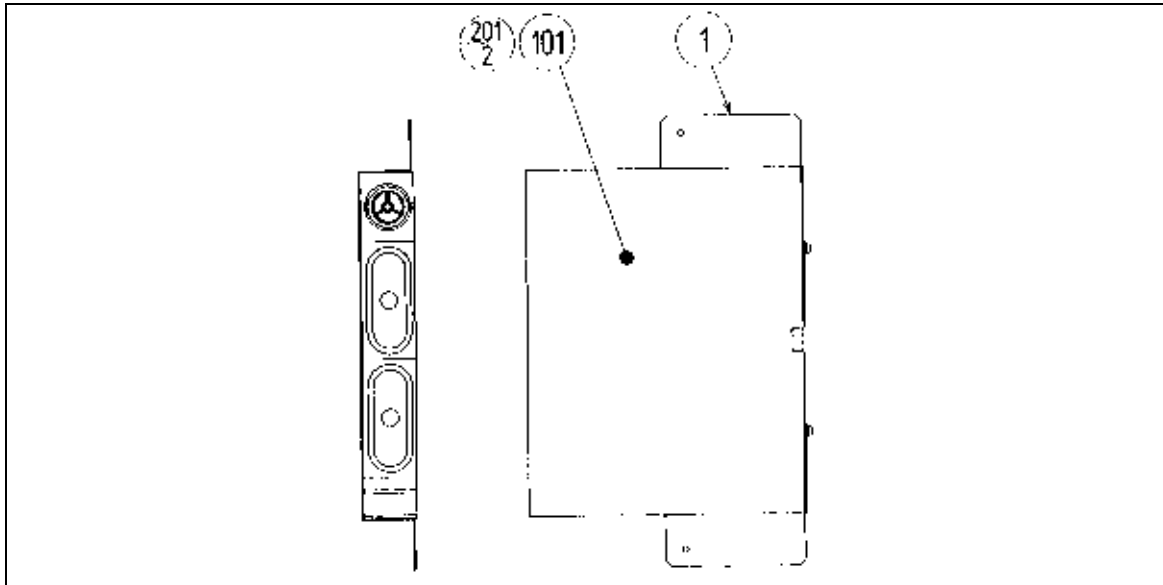

ITEM	PART NO.	QTY	DESCRIPTION	COMPONENT REF.
1	APC-1561	1	SPEAKER BRKT	
101	130-5156	1	SPEAKER BOX 8OHM 20W	TWEETER @ TOP
201	000-P00512-W	2	M SCR PH W/FS M5X12	(101)-2

### 8.9. FZR-20001UK ASSY CONTROL PANEL STD

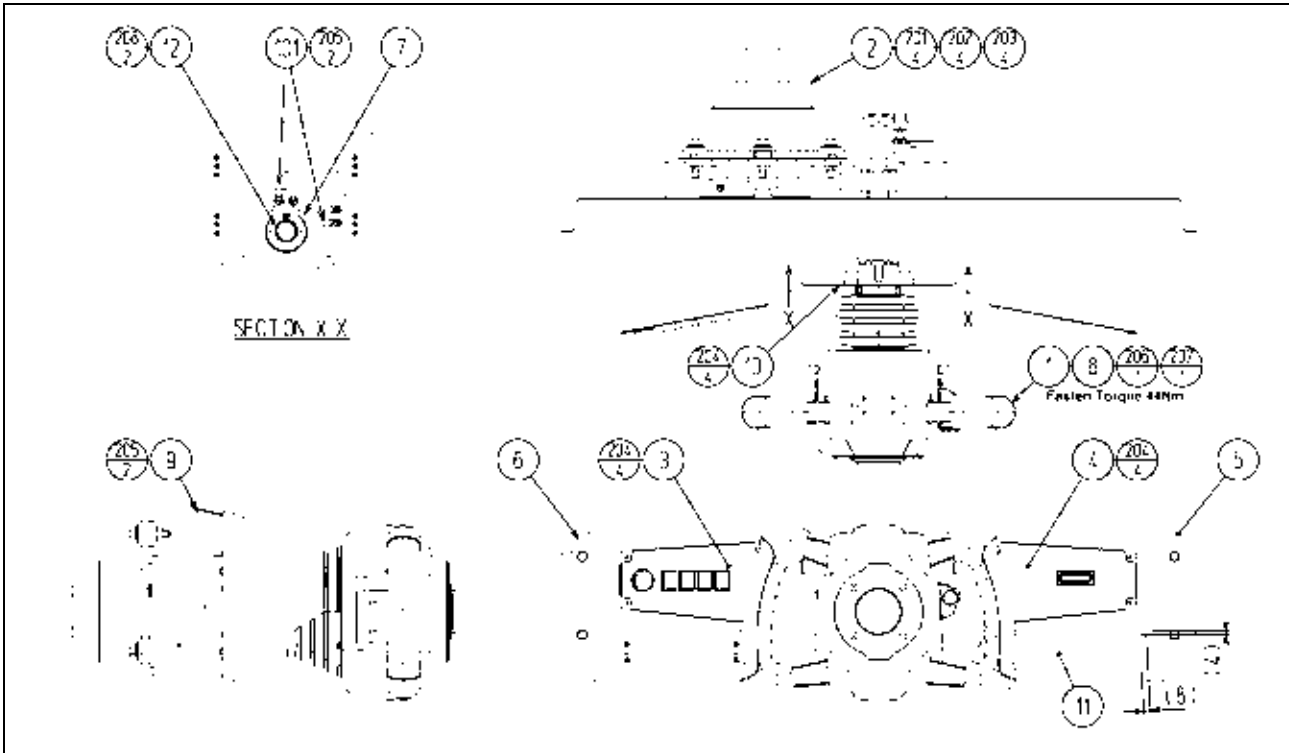

ITEM	PART NO.	QTY	DESCRIPTION	COMPONENT REF.
1	FZR-2500	1	ASSY STEERING	
2	FZR-2600	1	ASSY HANDLE MECHA	
3	FZR-2150UK	1	ASSY START VIEW	
4	FZR-2160UK	1	ASSY MEMORY SLOT	
5	FZR-2020	1	CONTROL PANEL COVER	
6	FZR-2021UK	1	CONTROL PANEL BRKT	
7	FZR-2022UK	1	HANDLE COLLAR	
8	FZR-0014UK	1	HANDLE SPACER RING	
9	TOF-2006UK	1	COVER HOLDER	
10	FZR-2023	1	CTRL PNL COVER LID	
12	FZR-1019	1	WIRE HOLDER	
15	440-WS0220UK	1	WARNING STICKER TRAP HAZARD	
16	MGL-2003	1	DENOMINATION PLATE	
101	280-D16636	2	CABLE NYLON SCR MTG 166L 3.6W	
102	601-0460	4	CABLE TIE 100mm	
103	280-A02000-A	6	ROUTER TWIST D20 ADH	
104	601-6231-C100	1	EDGING NEW TYPE	
106	280-A01200-A	3	ROUTER TWIST D12 ADH	

Cont.

ITEM	PART NO.	QTY	DESCRIPTION	COMPONENT REF.
201	050-U00800	4	M8 NUT NYLOK PAS	(2)-4
202	060-S00800	4	M8 WSHR SPR PAS	(2)-4
204	000-T00412-0B	14	M4X12 MSCR TH BLK	(3)-4,(4)-4,(10)-4,(16)-2
205	000-P00408-W	4	M4X8 MSCR PAN W/FS	(9)-2,(101)-2
206	050-U01000	1	M10 NUT NYLOK PAS	(1)-1
207	060-S01000	1	M10 WSHR SPR PAS	(1)-1
208	000-F00310	2	M3X10 MSCR CSK PAS	(12)-2
209	000-P00408	2	M4X8 MSCR PAN PAS	earth?
210	060-S00400	2	M4 WSHR SPR PAS	earth?
211	060-F00400	2	M4 WSHR FORM A FLT PAS	earth?
301	TOF-60016UK	1	WH EXT VOLUME C	
302	600-6873-043	1	WIRE HARN VIEW BUTTON	
303	FZR-61008UK	1	WH EXT HANDLE	
304	CKT-62037UK	1	WIRE HARN ENCODER EXT 2	
305	CKT-62036UK	1	WIRE HARN SERVO OUTPUT EXT 2	
306	FZR-61019UK	1	WH EXT MEM CARD C	
307	FZR-61020UK	1	WH EXT MEM CARD PWR C	

## 8.10. FZR-2500 ASSY STEERING





ITEM	PART NO.	QTY	DESCRIPTION	COMPONENT REF.
1	FZR-2501		HANDLE	
2	FZR-2502		STEERING COVER FRONT	
3	FZR-2503		STEERING COVER REAR	
4	FZR-2504		STEERING BELLOWS	
5	FZR-2505		GEAR 77	
6	FZR-2506		BOOST PANEL	
7	FZR-2507		SUB BOOST PANEL	
8	FZR-2508		SUB BOOST HOLDER	
9	FZR-2509		STEERING SHAFT BASE	
10	FZR-2510		STEERING BASE A	
11	FZR-2511		STEERING BASE B	
12	FZR-2512		STEERING STAND L	
13	FZR-2513		STEERING STAND R	
15	FZR-2515		CENTERING BASE	
16	FZR-2516		CENTERING SHAFT	
17	FZR-2517		CENTERING COLLAR	
18	FZR-2518		CENTERING SPRING A	
19	FZR-2519		PADDLE L	
20	FZR-2520		PADDLE R	
21	FZR-2521		PIN L	
22	FZR-2522		PIN R	
23	FZR-2523		PADDLE SHAFT A	
24	FZR-2524		PADDLE SHAFT B	
25	FZR-2525		PADDLE STOPPER PIN	
26	FZR-2526		PADDLE SPRING	
27	FZR-2527		STOPPER SHAFT	
28	FZR-2528		STOPPER RUBBER	
29	FZR-2529		SW ADJUST PLATE	
30	FZR-2530		BUSH	
31	FZR-2531		CENTERING SPRING B	
32	FZR-2532		HEX SPACER	
33	FZR-2533		BOOST BUTTON BASE B	
34	FZR-2534		BEARING COLLAR	
35	FZR-2535		INSULATION SHEET	
36	FZR-2536		HANDLE COLLAR	
37	FZR-2537		BELLOWS PLATE A	
38	FZR-2538		BELLOWS PLATE B	
39	FZR-2539		COVER STAY A	
40	FZR-2540		COVER STAY B	
41	FZR-2541		COVER STAY L	
42	FZR-2542		COVER STAY R	
43	FZR-2543		PADDLE COVER L	
44	FZR-2544		PADDLE COVER R	
45	FZR-2545		SLIDE PLATE L	

Cont.

ITEM	PART NO.	QTY	DESCRIPTION	COMPONENT REF.
46	FZR-2546		SLIDE PLATE R	
47	FZR-2547		BOOST BUTTON PLATE	
48	FZR-2548		SUB BOOST STAY	
49	350-5580		GEAR 10.5	
50	FZR-2549		CORD CLAMP STAY	
51	FZR-2550		SPONGE SHEET	
101	509-6035		SW OBSA-60UMQ-B-1TLED-B-12V	
102	509-5524-01		PUSH BUTTON SW BLUE	
103	220-5775		VOL CONT B-10K OHM W/BD	
104	509-6036		SW MICRO MATSUSHITA AM51615A7	
105	100-5365-0803		OILES BEARING 80F 0803	
106	100-5102		BEARING 9 NSK F699ZZ	
107	280-6622-40080		SPACER TUBE	
108	601-6563-48		BUSH 2.4T	
109	280-5008		CORD CLAMP 15	
110	280-5275-SR10		CORD CLAMP SR10	
111	280-0419		HARNESS LUG	
112	310-5029-D15		SUMITUBE F D 15MM	
113	310-5029-G20		SUMITUBE F G 20MM	
114	280-5257		TIE BASE TA1S8	
115	601-0460		PLASTIC TIE BELT 100 MM	
201	028-A00304-P		SET SCR HEX SKT CUP P M3• ~4	
202	028-A00404-P		SET SCR HEX SKT CUP P M4• ~4	
203	000-P00510-W		M SCR PH W/FS M5• ~10	
204	000-P00408-W		M SCR PH W/FS M4• ~8	
205	000-P00412-WB		M SCR PH W/FS BLK M4• ~12	
206	FAS-000125		M SCR PH W/SMALL FS BLK M4• ~14	
207	000-P00420-W		M SCR PH W/FS M4• ~20	
208	000-P00316-W		M SCR PH W/FS M3• ~16	
209	000-P00306-W		M SCR PH W/FS M3• ~6	
210	000-T00406-0B		M SCR TH BLK M4• ~6	
211	FAS-000124		M SCR TH BLK M4• ~4	
212	FAS-200053		HEX SKT H CAP SCR CRM M4• ~10	
213	050-F00500		FLG NUT M5	
214	020-000520-0Z		HEX SKT H CAP SCR BLK M5• ~20	
215	060-S00500-0B		SPR WSHR BLK M5	
216	031-000410-0B		CRG BLT BLK M4• ~10	
217	050-F00400		FLG NUT M4	
218	060-S00400-0B		SPR WSHR BLK M4	
219	FAS-600019		SPR WSHR BLK D=8.5 M5	
220	020-000412-0Z		HEX SKT H CAP SCR BLK OZ M4• ~12	

### 8.11. FZR-2600 ASSY HANDLE MECHA

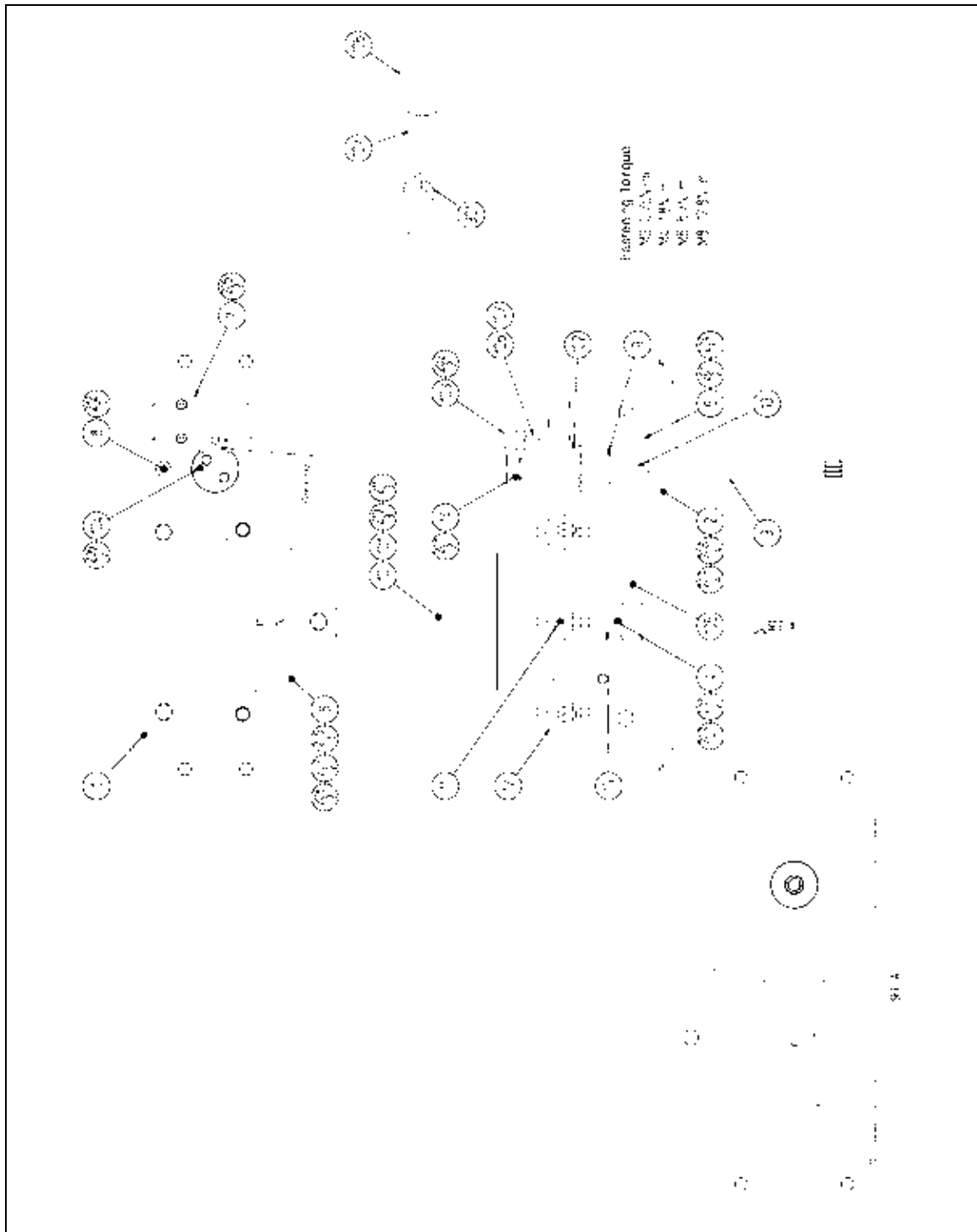

ITEM	PART NO.	QTY	DESCRIPTION	COMPONENT REF.
1	SPG-2501X		HANDLE BASE	
2	SPG-2502		BASE LID	
3	FZR-2601		HANDLE SHAFT	
4	SPG-2504		PULLEY 20 S5M	
5	SPG-2505		PULLEY 60 S5M	
6	SPG-2506		MOTOR BRKT	
7	FZR-2602		VR BRKT	
8	SPG-2108		STOPPER BOLT	
9	SPG-2109		STOPPER RUBBER	
10	SPG-2453		KEY 4• ~4• ~40	
11	ASK-3502		MOTOR SPACER	
12	ASK-3503		MOTOR COLLAR	
13	DYN-1270		STOPPER KEY	
14	SLC-1130		ADJUST RING	
15	SPG-2454		MOTOR SHAFT COLLAR	
101	350-5448-01		SERVO MOTOR 500W NEW	
102	100-5112		BEARING 17 (NSK 6003ZZ)	
103	601-7945		GEAR 20	
104	601-6172		GEAR 48	
105	601-9173		TIMING BELT (150 S5M 475)	
106	220-5484		VOL CONT B-5K OHM	
106	220-5753		VOL CONT B-5K OHM (TOCOS)	
107	310-5029-F20		SUMITUBE F F 20MM	
201	028-A00408-P		SET SCR HEX SKT CUP P M4• ~8	
202	028-A00308-P		SET SCR HEX SKT CUP P M3• ~8	
203	065-S012S0-Z		STP RING BLK OZ S12	
204	065-S020S0-Z		STP RING BLK OZ S20	
205	000-P00408-W		M SCR PH W/FS M4• ~8	
206	000-P00412-W		M SCR PH W/FS M4• ~12	
207	030-000612-S		HEX BLT W/S M6• ~12	
208	060-F00600		FLT WSHR M6	
209	050-U00600		U NUT M6	
210	030-000840-S		HEX BLT W/S M8• ~40	
211	068-852216		FLT WSHR 8.5-22 • ~1.6	
212	050-U00800		U NUT M8	
301	600-6866		WIRE HARN ASSY HANDLE MECHA VR	

### 8.12. FZR-2150UK-ASSY START VIEW

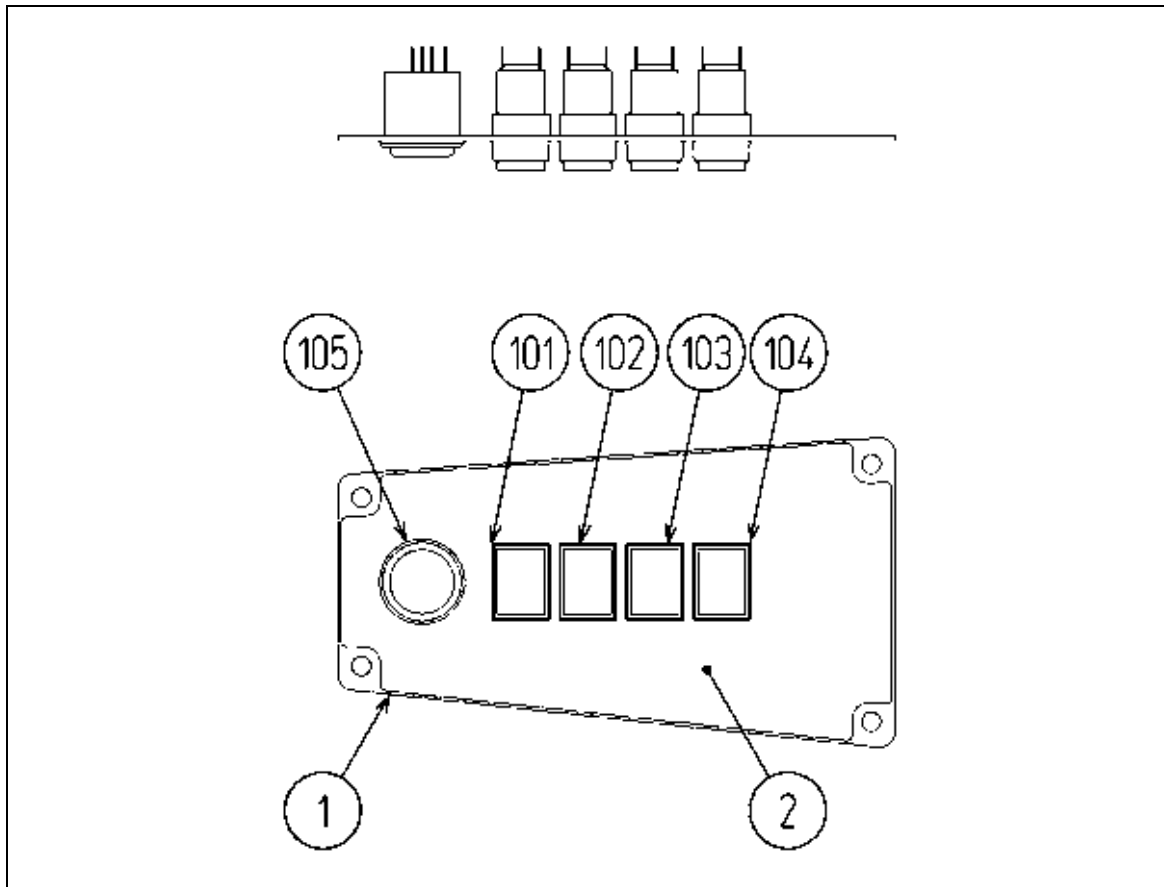

ITEM	PART NO.	QTY	DESCRIPTION	COMPONENT REF.
1	FZR-2151	1	START VIEW PLATE	
2	FZR-2152	1	STICKER START VIEW	
101	509-5779-RE	1	SW PB W/LAMP 6V RED	
102	509-5779-BL	1	SW PB W/LAMP 6V BLUE	
103	509-5779-YE	1	SW PB W/LAMP 6V YELLOW	
104	509-5779-GR	1	SW PB W/LAMP 6V GREEN	
105	509-0161	1	SW PB TYPE 1T YEL W/LAMP	
301	FZR-61021UK	1	WH VR SW	

### 8.13. FZR-2160UK ASSY MEMORY SLOT

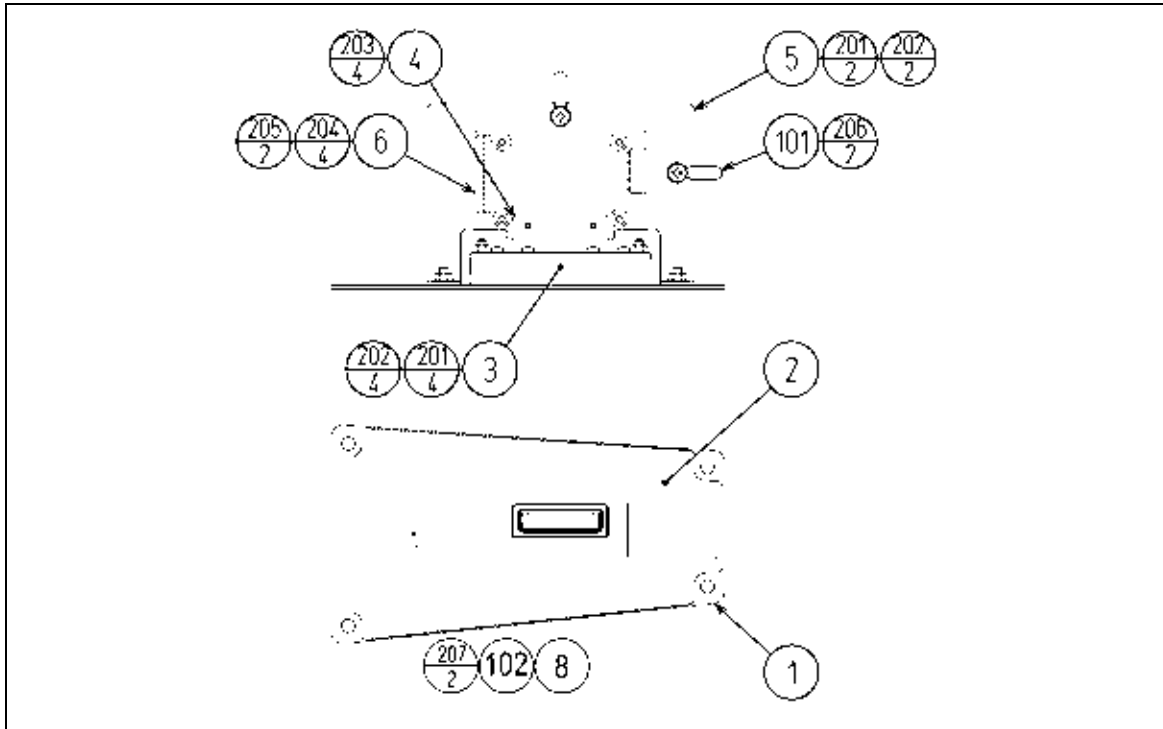

ITEM	PART NO.	QTY	DESCRIPTION	COMPONENT REF.
1	FZR-2161UK	1	MEMORY SLOT PLATE	
2	FZR-2162UK	1	STICKER MEMORY SLOT	
3	FZR-1293	1	MEMORY SLOT BASE	
4	FZR-1294	1	MEMORY SLOT HOLD BRKT	
5	FZR-2163	1	MEMORY BD BASE STD	
6	837-14399	1	MEMORY CARD I/F MC BD	
8	117-5164UK	1	PLATE START 37x42 UK	
101	280-D16636	2	CABLE NYLON SCR MTG 166L 3.6W	
102	509-5440	1	PUSH BTN SW IT GRN W/L DC 14V	(8)-1
201	050-U00400	6	M4 NUT NYLOK PAS	(3)-4,(5)-2
202	060-F00400	6	M4 WSHR FORM A FLT PAS	(3)-4,(5)-2
203	012-P00308	4	N4X5/16" S/TAP PAN PAS	(4)-4
204	000-P00320-W	4	M3X20 MSCR PAN W/FS	(6)-4
205	FAS-000128	2	M2X8 MSCR PH W/FS	(6)-2
206	000-P00408-W	2	M4X8 MSCR PAN W/FS	(101)-1
207	050-F00300	2	M3 NUT FLG SER PAS	(8)-2
301	FZR-60077UK	1	WH MEM CARD01	
302	FZR-60078UK	1	WH MEM CARD02	
303	TOT-61078UK	1	WH PLAYER SELECT SW	

8.14. ORT-1100UK ASSY PEDAL BASE ORT

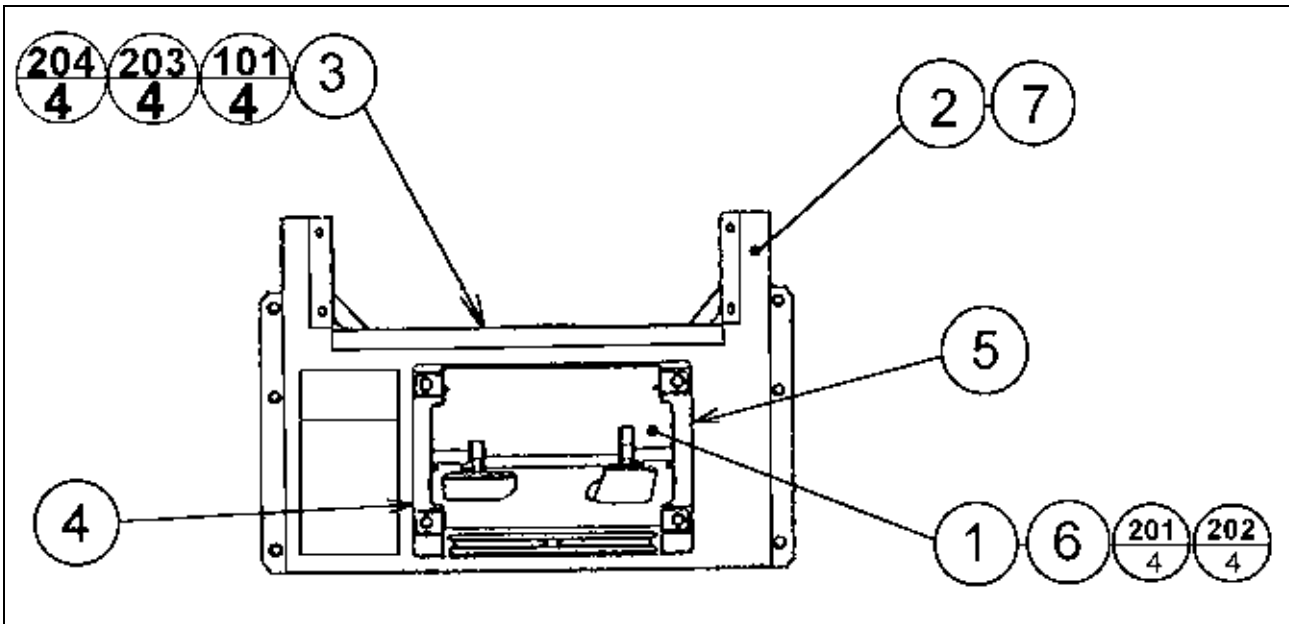

ITEM	PART NO.	QTY	DESCRIPTION	COMPONENT REF.
1	SPG-2200	1	ASSY BRAKE & ACCELL	
2	TOF-1501UK	1	PEDAL BASE	
3	FZR-1021UK	1	WIRE COVER BOX	
4	SPG-2222UK	1	ANTI FINGER TRAP PLATE LEFT	
5	SPG-2223UK	1	ANTI FINGER TRAP PLATE RIGHT	
6	SPG-2224UK	1	PEDAL GASKET	
7	SRT-2031UK	0.52	NEOPRENE RUBBER STRIP 10	(2)-520mm X1 INSIDE FLANGE
101	280-A01200-A	6	ROUTER TWIST D12 ADH	WIRE COVER BOX
201	068-852216-0B	4	M8 WSHR 22OD FLT BLK	(1)-4
202	030-000820-SB	4	M8X20 BLT W/S BLK	(1)-4
203	000-P00408-WB	4	M4X8 MSCR PAN W/FS BLK	(3)-4
204	050-F00400	3	M4 NUT FLG SER PAS	(3)-3 EARTHS
301	600-9050-44K	1	WIRE HARN EARTH 500mm M4/M4 K	WIRE COVER TO MAIN BASE

### 8.15. SPG-2200 ASSY BRAKE & ACCELL

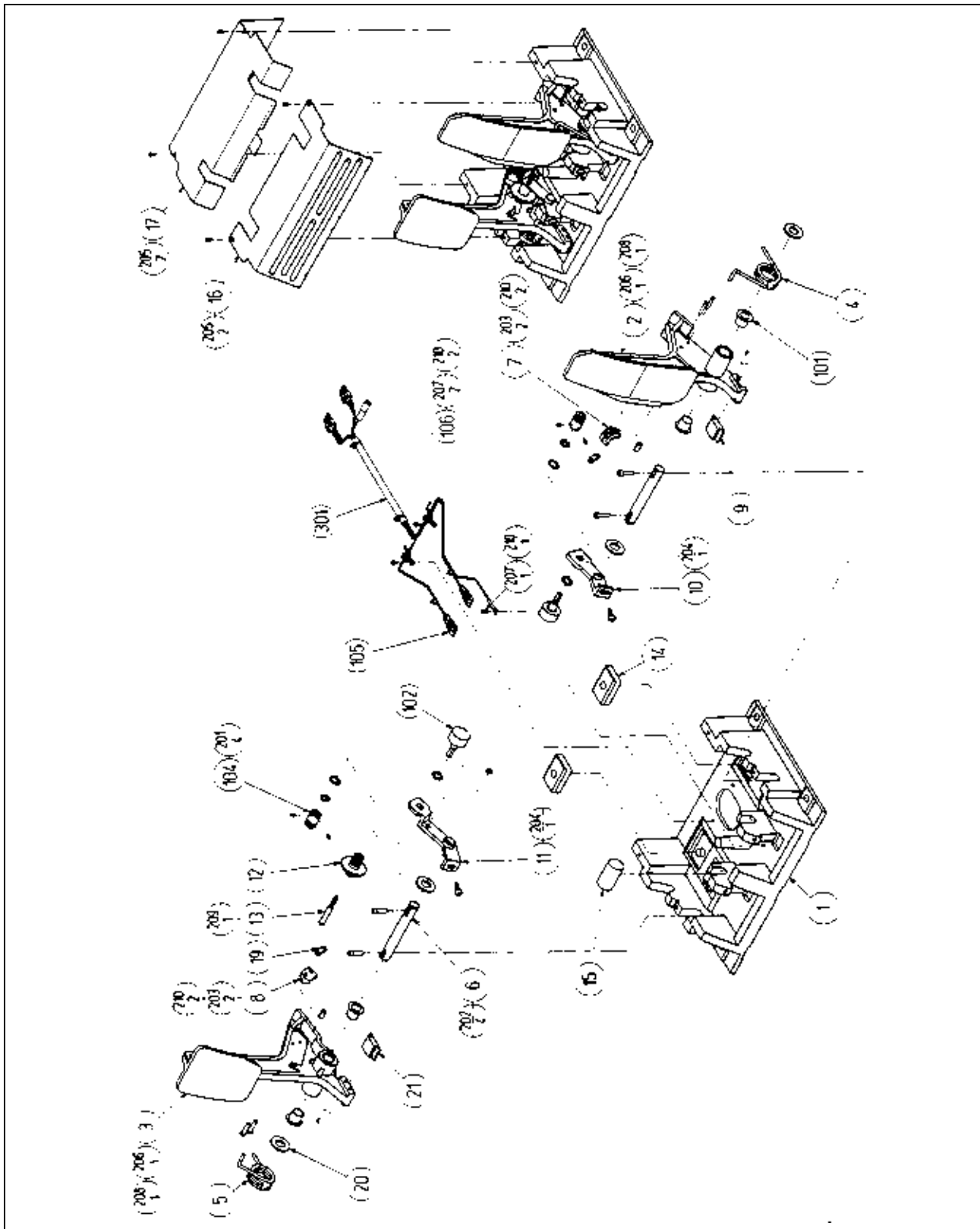



ITEM	PART NO.	QTY	DESCRIPTION	COMPONENT REF.
1	SPG-2201	1	BASE	
2	SPG-2202	1	ACCEL PEDAL	
3	SPG-2203	1	BRAKE PEDAL	
4	SPG-2204	1	ACCEL SPRING	
5	SPG-2205	1	BRAKE SPRING	
6	SPG-2206	2	SHAFT	
7	SPG-2207	1	ACCEL	
8	SPG-2208	1	BRAKE GEAR	
9	SPG-2209	1	NEUTRAL STOPPER	
10	SPG-2210	1	VR PLATE ACCEL	
11	SPG-2211	1	VR PLATE BRAKE	
12	SPG-2212	1	AMPL GEAR	
13	SPG-2213	1	GEAR SHAFT	
14	SPG-2214	2	STOPPER	
15	SPG-2215	1	RUBBER CUSHION	
16	SPG-2216	1	COVER	
17	SPG-2217	1	VR COVER	
19	SPG-2219	2	GEAR STAY	
20	SPG-2220	4	WSHR	
21	SPG-2221	1	NEUTRAL STOPPR D	
101	100-5263	4	BEARING 12 (OILES 80F-1212)	
102	220-5484	2	VOL CONT B-5K OHM	
104	601-7944	2	GEAR 15	
105	310-5029-F15	6	SUNITUBE F F15MM	
106	280-0419	2	HARNESS LUG	
201	028-A00304-P	4	SET SCR HEX SKT CUP P M3X4	
202	020-000516-OZ	4	HEX SKT H CAP SCR BLK OZ M5X16	
203	000-P00420	4	M SCR PH M4X20	
204	000-P00508-W	2	M SCR PH W/FS M5X8	
205	000-T00408-OC	4	M SCR TH CRM M4X8	
206	FAS-450005	2	SPR PIN BLK OZ 6X10	
207	000-P00405	3	M SCR PH M4X5	
208	FAS-000001	2	M SCR TH CRM M3X6	
209	050-H00500	1	HEX NUT M5	
210	060-F00400	7	FLT WSHR M4	

8.16. FZR-1600UK ASSY SEAT TWIN 1P

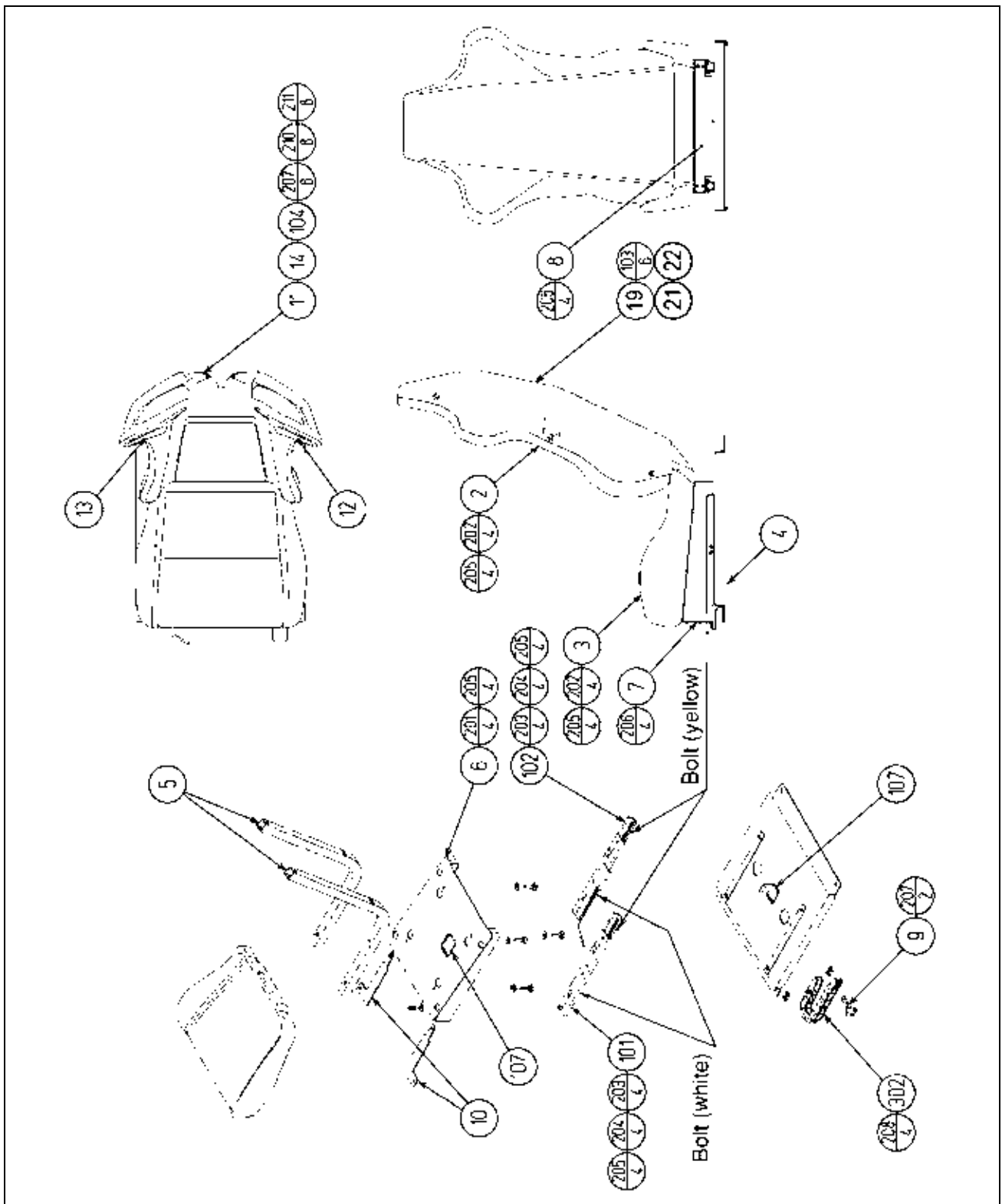

ITEM	PART NO.	QTY	DESCRIPTION	COMPONENT REF.
2	SPG-2401-AUK	1	UPPER SEAT BLANK	
4	SPG-2402-AUK	1	LOWER SEAT BLANK	
5	STC-1603	1	SEAT BASE	
7	STC-1604	2	SEAT FRAME	
8	STC-1606	1	SEAT MOUNT TRAY	
9	STC-1607	2	SP MOUNT BRKT	
10	STC-1608	1	SPEAKER NET L	
11	STC-1609	1	SPEAKER NET R	
12	STC-1610	1	SAFETY GUARD	
14	STC-1612	2	PROTECT RUBBER	
15	STC-1613	1	SAFETY GUARD F	
16	OS1004	0.8	DRAFT EXCLDR 4 X7MM BLK x 10M	(103)-0.8M
17	SPG-2401-BUK	1	UPPER SEAT INSERT	(2)-1
18	SPG-2402-BUK	1	LOWER SEAT INSERT	(4)-1
19	FZR-1601-AUK	1	SEAT BACK COVER BLANK UK	
20	SRT-2409	2	SHOULDER PAD	BETWEEN SPKR NETS & SEAT
21	FZR-1601-BUK	1	STICKER SEAT BACK	
22	FZR-1601-CUK	1	STICKER SEAT BACK LOGO	
101	601-9059-91	1	SEAT RAIL L	
102	601-9060-91	1	SEAT RAIL R	
103	130-5186-91	2	DUMMY SPEAKER	
104	280-K02529-WX	18	DRIVE FASTENER 25FH 24L 7.9DIA	(17)-8,(18)-10
105	280-5297	6	SCRIVET 8 1K31	(19)-6
201	030-000850-S	8	M8X50 BLT W/S PAS	(2)-4,(4)-4
202	068-852216	20	M8 WSHR 22OD FLT PAS	(2,4,8,101,102)-4EA
203	030-000816-S	4	M8X16 BLT W/S PAS	(8)-4
204	000-P00410-W	8	M4X10 MSCR PAN W/FS PAS	(9)-8
205	000-T00408-0B	8	M4X8 MSCR TH BLK	(12)-4,(15)-4
206	012-P03512-F	8	N6X1/2" S/TAP FLG PAS	(103)-8
207	050-U00800	8	M8 NUT NYLOK PAS	(101)-4,(102)-4

### 8.17. FZR-4500UK ASSY MAIN BD

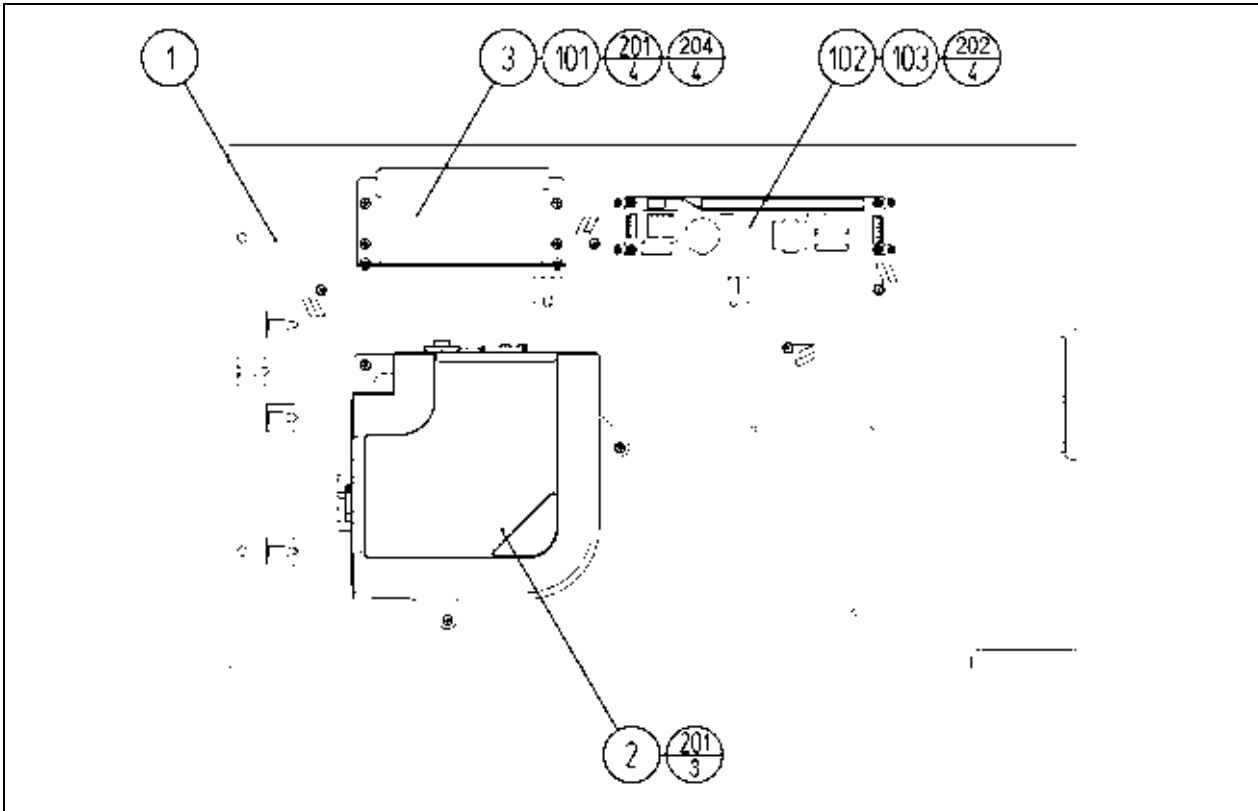

ITEM	PART NO.	QTY	DESCRIPTION	COMPONENT REF.
1	ORT-4501UK	1	MAIN BD BASE	
2	842-02DD511E	1	ASSY TRF FZR EXP	
3	APC-4002	1	SW REG BRKT	
4	105-5435	1	GD DRIVE BRKT STD	
5	LB1111	1	STICKER PLEASE RECYCLE	
6	610-0617	1	GD-ROM DRIVE UNIT NAOMI	
7	610-0649-0004	1	GD SOFT FZR	
101	400-5397-01	1	SW REGU FOR JVS VA	
102	400-5421-07512	1	SW REGU LCA75S-12	
103	OS1071	1	FEET P.C.B PKT OF 4	(102)-4 FEET
104	354081	4	TWIST LOK BHKL-450-4	
105	354083	4	(A)TWIST N LOK BHKL-750-4	
106	280-A00964-WX	6	ROUTER TWIST D09 SO6.4	
107	LB1101	1	STICKER WARNING BATTERY	GAME BD
201	000-P00416-W	10	M4X16 MSCR PAN W/FS PAS	(2)-3,(4)-3,(3)-4
202	012-P03516	4	N6X5/8" S/TAP PAN PAS	(102)-4
203	012-P00410-F	4	N8X3/8" S/TAP FLG PAS	(6)-4
204	000-P00408-W	4	M4X8 MSCR PAN W/FS PAS	(101)-4
302	TOF-60002UK	1	WH MAIN BD AC	
303	TOF-60003UK	1	WH JVS PWR 6P W/CARD	
304	TOF-60004UK	1	WH JVS PWR 8P W/GD	
307	600-7247-500	1	CABLE SCSI ST-L TYPE2 500MM	

### 8.18. FZR-4600UK ASSY ELEC BD

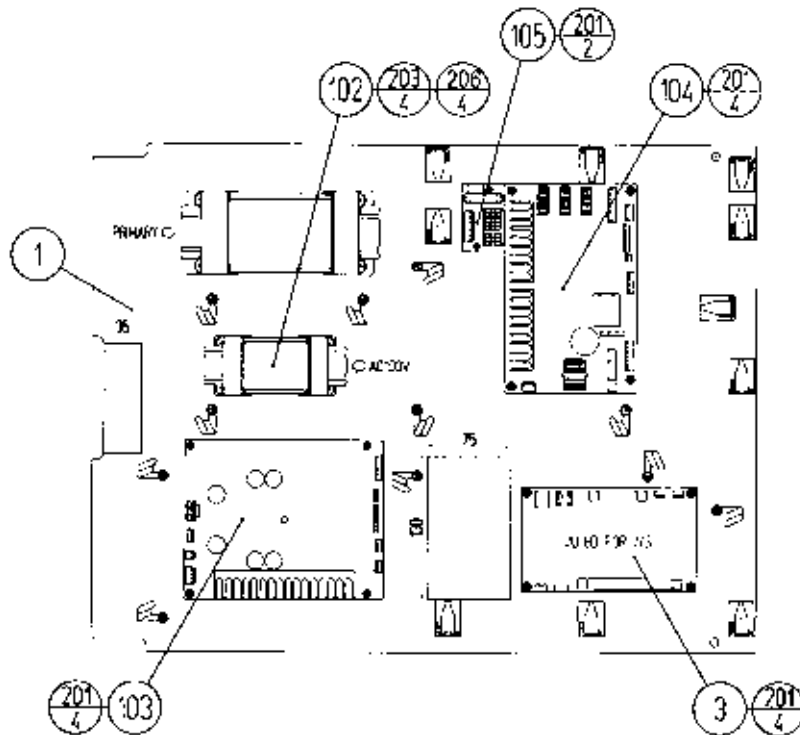

ITEM	PART NO.	QTY	DESCRIPTION	COMPONENT REF.
1	TOF-4601UK	1	WOODEN BASE ELEC	
3	837-13551-92	1	I/O CONTROL BD FOR JVS	
102	560-5394UK	1	TRANSFORMER DUT TW	
103	838-13578	1	PWR AMP 2CH & MIXER	
104	838-14174	1	SERVO MOTOR DRIVE BD MIDI	
105	838-11856CE-02	1	CONNECT BD W/FUSE 6.3A CE	
107	354081	11	TWIST LOK BHKL-450-4	
108	354083	10	(A)TWIST N LOK BHKL-750-4	
109	280-A00964-WX	12	ROUTER TWIST D09 SO6.4 WOOD X	
201	012-P00325	14	N4X1" S/TAP PAN PAS	(3)-4,(103)-4,(104)-4,(105)-2
203	000-P00416-W	4	M4X16 MSCR PH W/FS	(102)-4
206	068-441616	4	M4 WSHR 16OD FLT PAS	(102)-4
301	600-7141-100	1	CABLE JVS TYPE A-B 100CM	
302	600-6985-006UK	1	WIRE HARN 100V OUT	
303	FRI-61003UK	1	WIRE HARN CONN BD B	
305	FRI-61027UK	1	WIRE HARN EXT AC100V A	
306	TOF-60104UK	1	PWR AMP 14V AC IN	
307	NCR-61002UK	1	WH AMP VR	
309	NCR-61004UK	1	WH AMP SP F	

Cont.

ITEM	PART NO.	QTY	DESCRIPTION	COMPONENT REF.
310	ORT-60001UK	1	WH CONN BD OUT A HUB	
311	TOF-60007UK	1	WH MIDI	
312	TOF-60008UK	1	WH ELEC BD I/O PWR	
313	FZR-61003UK	1	WH I/O BD	
315	POD-61057UK	1	WH EARTH AC UNIT	
316	FRI-61030UK	1	WIRE HARN EXT MOTOR A	
317	TOF-60011UK	1	WH EXT ENCODER A	
318	TOF-60021UK	1	WH EXT AC100V B	
319	FZR-61017UK	1	WH MAIN BD SOUND	

**8.19. FZR-1510UK ASSY BASE LID R**

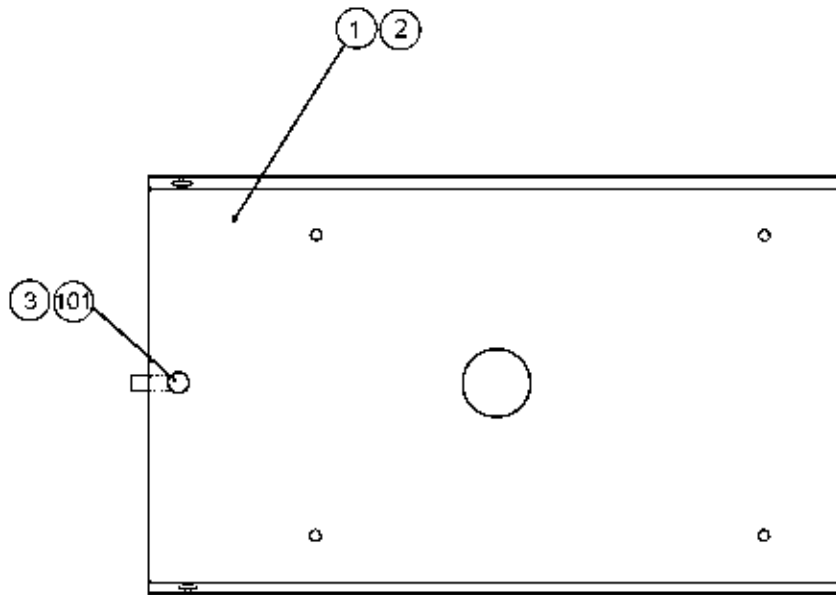

ITEM	PART NO.	QTY	DESCRIPTION	COMPONENT REF.
1	FZR-1511UK	1	BASE LID R	
2	DUT-1511-CUK	1	GASKET STRIP	(1)-1
3	DUT-1511-DUK	1	LOCK TONGUE DUT	(101)-1
101	220-5575UK	1	LOCK	
201	050-F00400	1	M4 NUT FLG	(301)-1
301	600-9020-44K	1	WIRE HARN EARTH 200mm M4/M4 K	R.FLOOR TO MAIN BASE

## 8.20. FZR-INST-TW ASSY INST KIT FZR TWIN

ITEM	PART NO.	QTY	DESCRIPTION	COMPONENT REF.
1	FZR-0200UK	1	ASSY BILLBOARD	
2	FRI-0300UK	1	ASSY COINCHUTE TOWER FRI	
3	ORT-0500UK	1	ASSY WIRE COVER ORT TWIN	
4	DYN-0013	1	JOINT PIPE	
5	DYN-0006XUK	1	AC COVER B	
6	SRT-0018UK	1	AC COVER C	
7	DYN-0019UK	1	AC COVER D	
8	RAL-XXXX-14UK	1	TIE BRACKET RALLY	
9	SPG-0008	2	BILLBOARD HOLDER	
10	422-0911UK	2	PLAY INSTR FZR TWIN MULTI	
11	422-0912UK	2	SUB INSTR FZR TWIN MULTI	
13	PK0347	1	INST KIT BOX FZR TWIN	
15	FZR-0022-01	2	STICKER CARD SLOT FZR B ENG	
16	601-11334-01	3	CARD PACKAGE FZR ENG	
17	601-11050-91	2	CLEANING KIT	
18	220-5753	1	VOL CONT B-5K OHM (TOCOS)	spare (mecha)
19	PK0343	0.5	PALLET INST KIT	
20	FZR-0020UK	2	STICKER CARD SLOT FZR C MULTI	
21	FZR-1297UK	2	STICKER MEMORY CAUTION MULTI	
22	FZR-2024UK	2	STICKER MEMORY SLOT LWR MULTI	
101	440-CS0186UK	2	STICKER C EPILEPSY MULTI	
104	OS1241	6.5	TAPE RF20 XWEAVE 50mmX50M ROLL	AROUND MONITOR
201	030-000825-SB	20	M8X25 BLT W/S BLK	(1,2,4)-4EA,(9)-8
202	068-852216-0B	20	M8 WSHR 22OD FLT BLK	(1,2,4)-4EA,(9)-8
203	000-P00412-WB	15	M4X12 MSCR PAN W/FS BLK	(3)-5,(5)-4,(6)-2,(7)-4
204	050-F00400	3	M4 NUT FLG SER PAS	(AC UNITS)-1EA, (2)-1
301	600-7269-0500	1	ASSY LAN CABLE 0500CM	
401	420-5827	1	SERVICE MANUAL SANWA 31K	
402	420-6770-01UK	1	SERVICE MANUAL FZR TWIN	
403	OS1019	2	SELF SEAL BAG 9X12.3/4	
404	540-0006-01	1	WRENCH M4 TMP PRF	
405	540-0007-01	1	WRENCH M5 TMP PRF	
406	540-0009-01	1	WRENCH M8 TMP PRF	
407	220-5484	1	VOL CONT B-5K OHM	spare (accel/brake)
408	SAECE-xxx	1	DECLARATION OF CONFORMITY	DECLARATION OF
409	514-5078-5000	2	FUSE 5X20 CERAMIC SB 5000mA	
411	420-6620UK	1	SERVICE MANUAL GD ROM SYSTEM	
416	509-6036	1	SW MICRO MATSUSHITA AM51615A7	
418	220-5775	1	VOL CONT B-10K OHM W/BD	spare (steering)



## 8.21. FZR-0200UK ASSY BILLBOARD

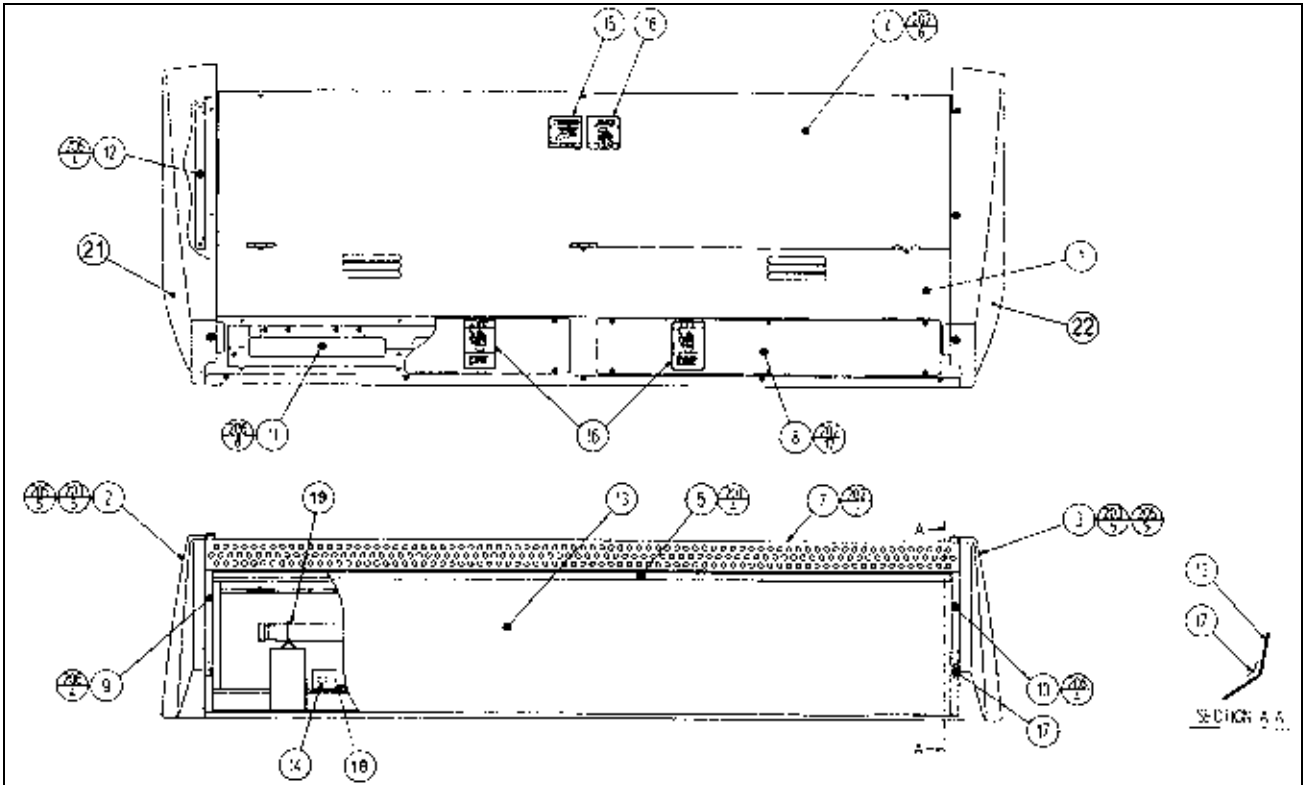

ITEM	PART NO.	QTY	DESCRIPTION	COMPONENT REF.
1	FRI-0201UK	1	BILLBOARD BOX	
2	FZR-0202UK	1	SIDE COVER L	
3	FZR-0203UK	1	SIDE COVER R	
4	FRI-0204UK	1	BILLBOARD LID	
5	FRI-0205	1	UPPER SASH	
7	ORT-0207UK	1	UPPER COVER	
8	FRI-0208	2	UPPER LID	
9	FRI-0209	1	SASH SIDE L	
10	FRI-0210	1	SIDE SASH R	
12	VOT-0208	2	SIDE COVER BRKT	
13	FZR-0215UK	1	BILLBOARD PLATE FZR TWIN	
14	421-7501-10	1	STICKER FL 40W	
15	LB1104	1	STICKER CAUTION, HOT SURFACE	ON BACK LID
16	LB1102	3	STICKER DANGEROUS VOLTAGE	BACK LID-1, UPPER LID-1EA
17	FRI-0211	2	CUSHION SPONGE 40	
18	390-5695-40-CUK	1	FL TRAY 110V 40W (T12)	
19	390-5695-40-BUK	1	FL TUBE 40W 4' DIA 1.5" T12	

Cont.

ITEM	PART NO.	QTY	DESCRIPTION	COMPONENT REF.
20	280-A00900-A	7	ROUTER TWIST D9 ADH	
21	FZR-0202-BUK	1	STICKER SIDE COVER L	
22	FZR-0203-BUK	1	STICKER SIDE COVER R	
202	000-T00408-0B	27	M4X8 MSCR TH BLK	(4)-6,(7)-9,(8)-12
203	000-T00412-0B	10	M4X12 MSCR TH BLK	(2)-5,(3)-5
205	068-441616-0B	13	M4 WSHR 16OD FLT BLK	(2)-5,(3)-5,(4)-3
206	000-P00408-W	12	M4X8 MSCR PAN W/FS PAS	(9)-4,(10)-4,(12)-4
207	050-F00400	5	M4 NUT FLG SER PAS	(101)-2,(EARTHS)-3
210	000-P00408	2	M4X8 MSCR PAN PAS	(102)-2
302	600-7064-031UK	1	WIRE HARN FL	
303	600-9020-44K	1	WIRE HARN EARTH 200mm	B/BD BOX- B/BD LID

8.22. FRI-0300UK ASSY COINCHUTE TOWER FRI

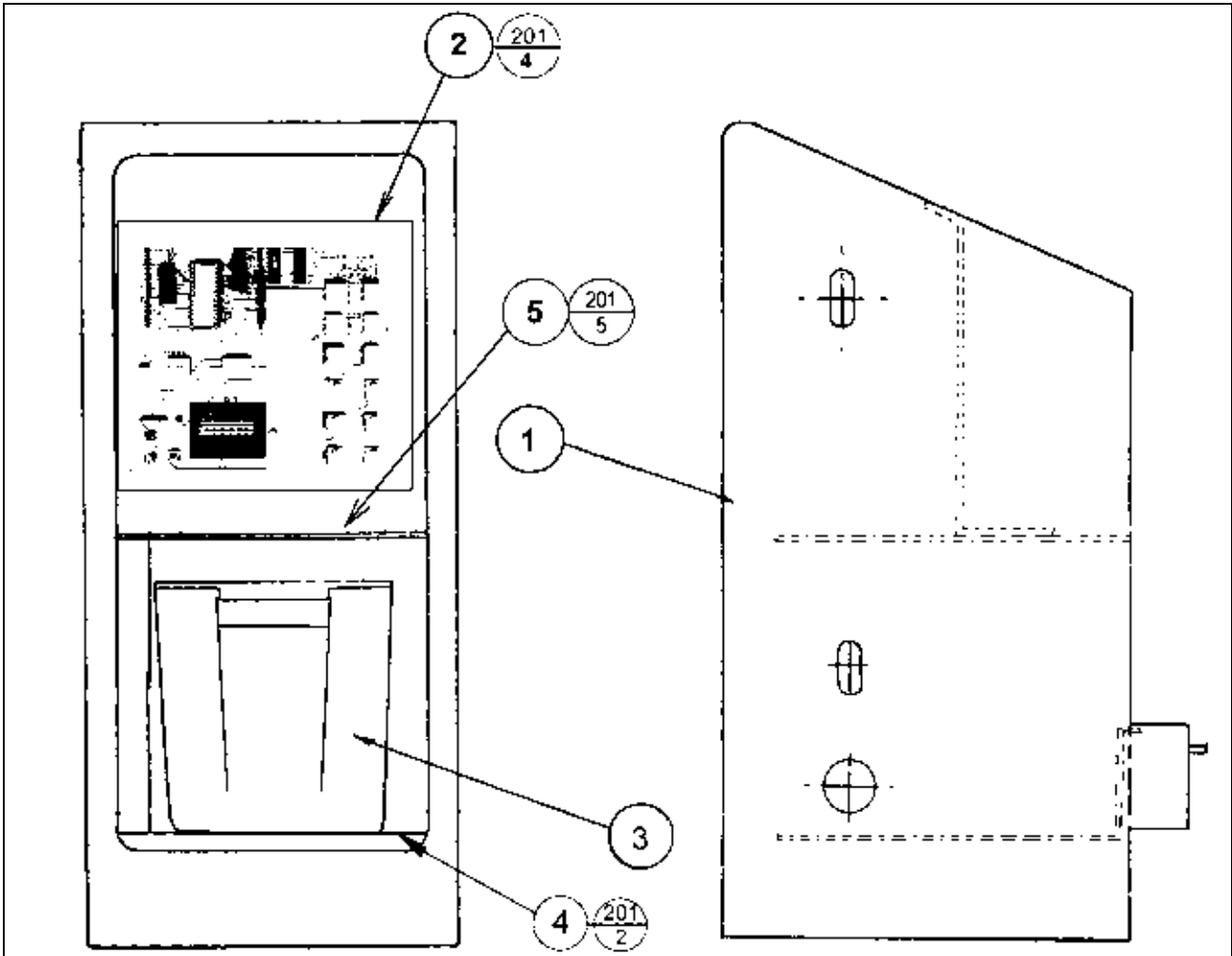

ITEM	PART NO.	QTY	DESCRIPTION	COMPONENT REF.
1	ECA-0301UK	1	COIN CHUTE TOWER ECA	
2	VTS-FRI-T	1	VTS BOARD FRI TWIN	
3	PP1087	1	BOX CASH FOR MINI DOOR	
4	SRT-0302UK	1	CCT FLOOR TWIN	
5	DUT-0302UK	1	COIN PATH PLATE	FIX TO TOP OF VAULT ROOF
201	000-P00410-W	11	M4X10 MSCR POSI PAN W/FS	(2)-4,(4)-2,(5)-5
301	FRI-61056UK	1	WIRE HARN VTS BOARD	

### 8.23. ORT-0500UK ASSY WIRE COVER ORT TWIN

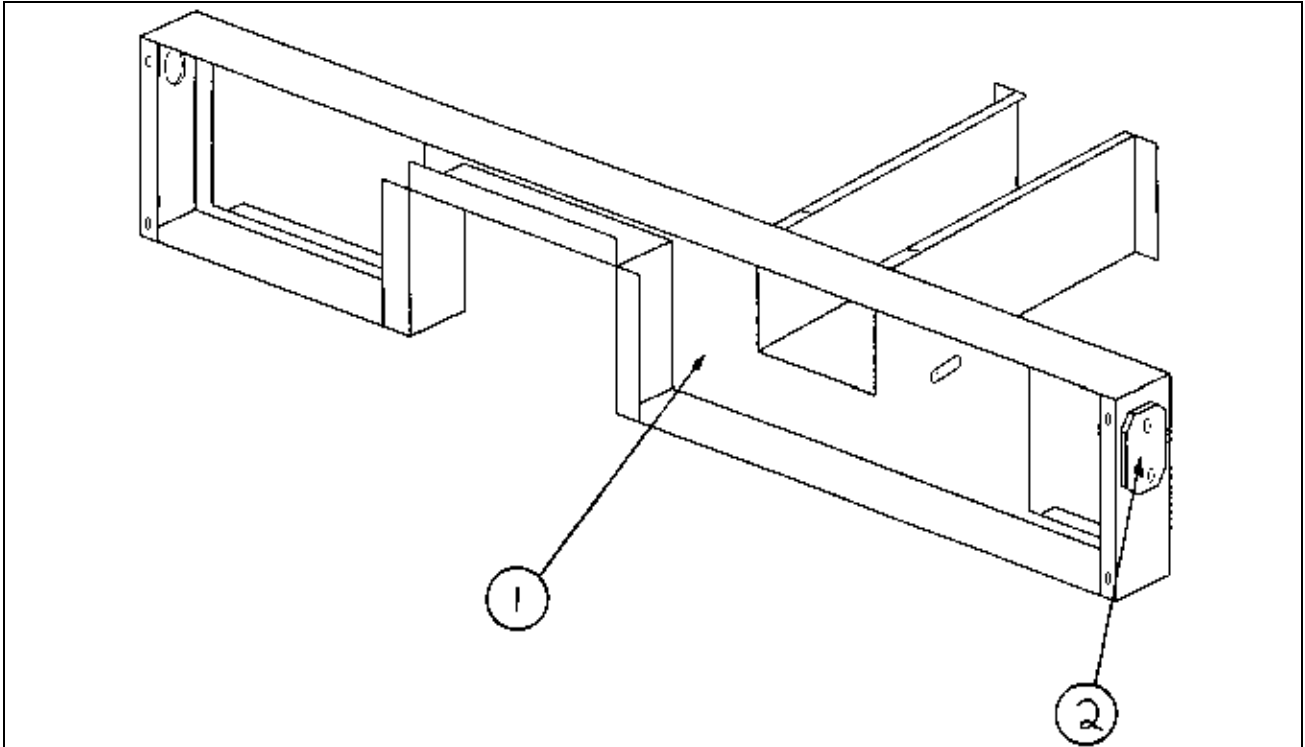

ITEM	PART NO.	QTY	DESCRIPTION	COMPONENT REF.
1	DYN-0005UK	1	AC COVER A	
2	DYN-0009UK	2	HOLE LID	(1)-2
201	000-P00308-WB	4	M3X8 MSCR PAN W/FS BLK	(2)-4
202	050-F00400	1	M4 NUT FLG SER PAS	EARTH - 1
203	280-A02000-A	5	ROUTER TWIST D20 ADH	(1)-5
301	600-6817-104	1	WIRE HARN EXT AC (SPG)	
302	600-6817-102	1	WIRE HARN EXT TOWER L (SPG)	
303	600-6817-103	1	WIRE HARN EXT TOWER R (SPG)	
304	600-6373-76	1	WIRE HARNESS PLAYER SEL EXT A	
305	600-9075-44K	1	WIRE HARN EARTH 750mm M4/M4 K	SUB AC-AC COVER
306	600-9030-44K	1	WIRE HARN EARTH 300mm M4/M4 K	MAIN AC-AC COVER
307	600-9040-45K	1	WIRE HARN EARTH 400mm M4/M5 K	AC COVER - CCT

### 8.24. ORT-0400UK ASSY AC BRKT MAIN

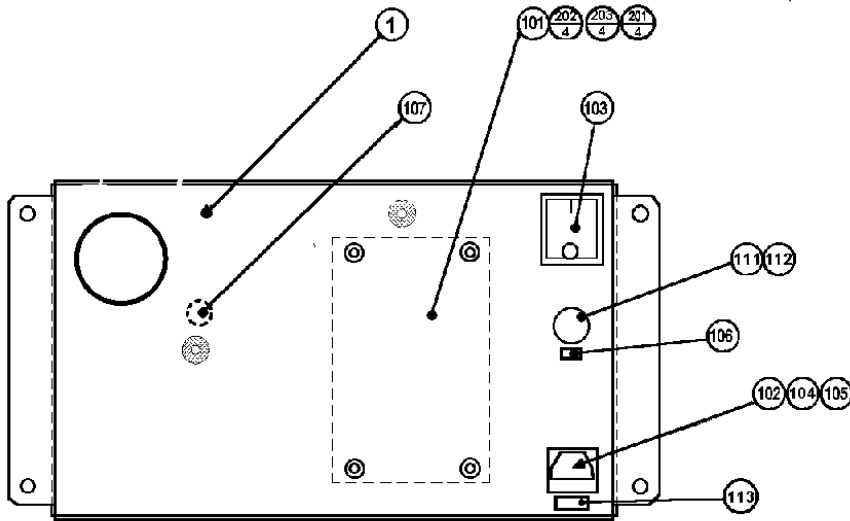

ITEM	PART NO.	QTY	DESCRIPTION	COMPONENT REF.
1	ORT-0401UK	1	AC BRKT UK	
101	EP1379	1	FILTER EMI 10A ARCOTRONICS	
102	EP1302	1	EUROSOCKET FUSED 10A 250Vac	
103	EP1303	1	SWITCH ROCKER DPST 10A 250Vac	
104	514-5078-10000	1	FUSE 5X20 CERAMIC SB 10000mA	IEC INLET
105	310-5029-D508	5	HEAT SHRINK SLEEVING 50.8DIA	OVER ITEM 102(50MM OVER SOCKET)
106	421-6595-5000-T	1	STICKER FUSE 5000mA TYPE T	FUSE HOLDER
107	LB1096	1	STICKER PROTECTIVE EARTH	EARTH POINT INSIDE
111	EP1334	1	FUSE HOLDER 20mm 10A 240Vac	
112	514-5078-5000	1	FUSE 5X20 CERAMIC SB 5000mA	
113	421-6595-10000T	1	STICKER FUSE 10000mA TYPE T	IEC INLET
114	360168	1	SNAP-BUSHING-HEYCO-400 2182	
201	060-S00300	4	M3 WSHR SPR PAS	(101)-4
202	060-F00300	4	M3 WSHR FORM A FLT PAS	(101)-4
203	000-P00310	4	M3X10 MSCR PAN PAS	(101)-4
204	050-F00400	3	M4 NUT FLG SER PAS	(INSIDE EARTH)-2,(OUTSIDE)-1
301	600-6873-001UK	1	WIRE HARN XFMR IN	
303	600-9030-44K	1	WIRE HARN EARTH 300mm M4/M4 K	AC BRKT TO MAIN BASE
304	600-9040-45K	1	WIRE HARN EARTH 400mm M4/M5 K	AC BRKT - XFMR

### 8.25. ORT-0700UK ASSY AC BRKT SUB

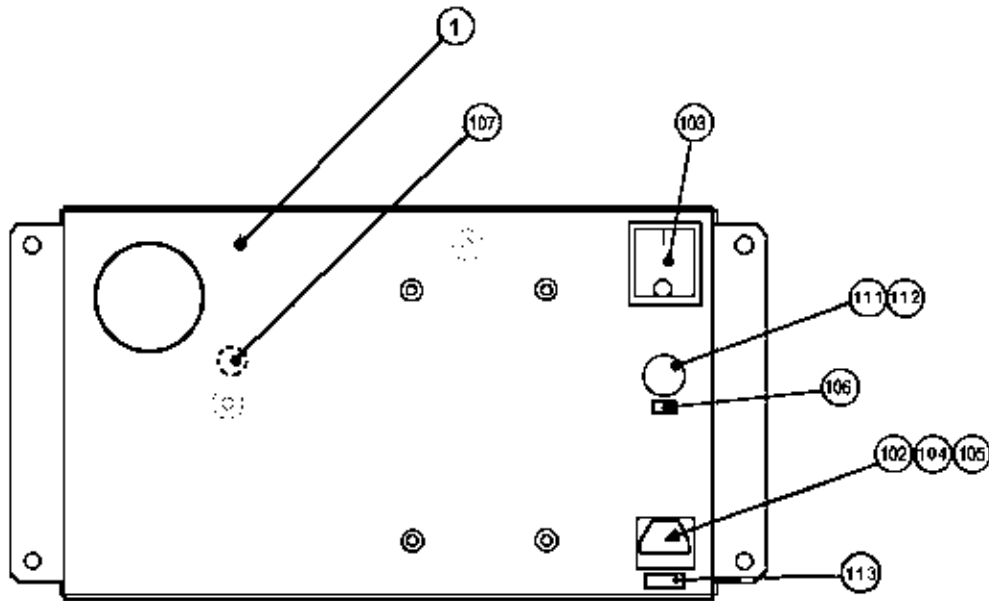

ITEM	PART NO.	QTY	DESCRIPTION	COMPONENT REF.
1	ORT-0401UK	1	AC BRKT UK	
106	421-6595-5000-	1	STICKER FUSE 5000mA TYPE T	FUSE HOLDER
107	LB1096	1	STICKER PROTECTIVE EARTH	EARTH POINT INSIDE
111	EP1334	1	FUSE HOLDER 20mm 10A 240Vac	
112	514-5078-5000	1	FUSE 5X20 CERAMIC SB 5000mA	
114	360168	1	SNAP-BUSHING-HEYCO-400 2182	
204	050-F00400	3	M4 NUT FLG SER PAS	(INSIDE EARTH)-2,(OUTSIDE)-1
303	600-9030-44K	1	WIRE HARN EARTH 300mm M4/M4 K	AC BRKT TO MAIN BASE
304	600-9040-45K	1	WIRE HARN EARTH 400mm M4/M5 K	AC BRKT - XFMR
305	600-6999-201UK	1	WIRE HARN SUB AC BRKT	

### 8.26. VOF-0450UK CARD UNIT TWIN L

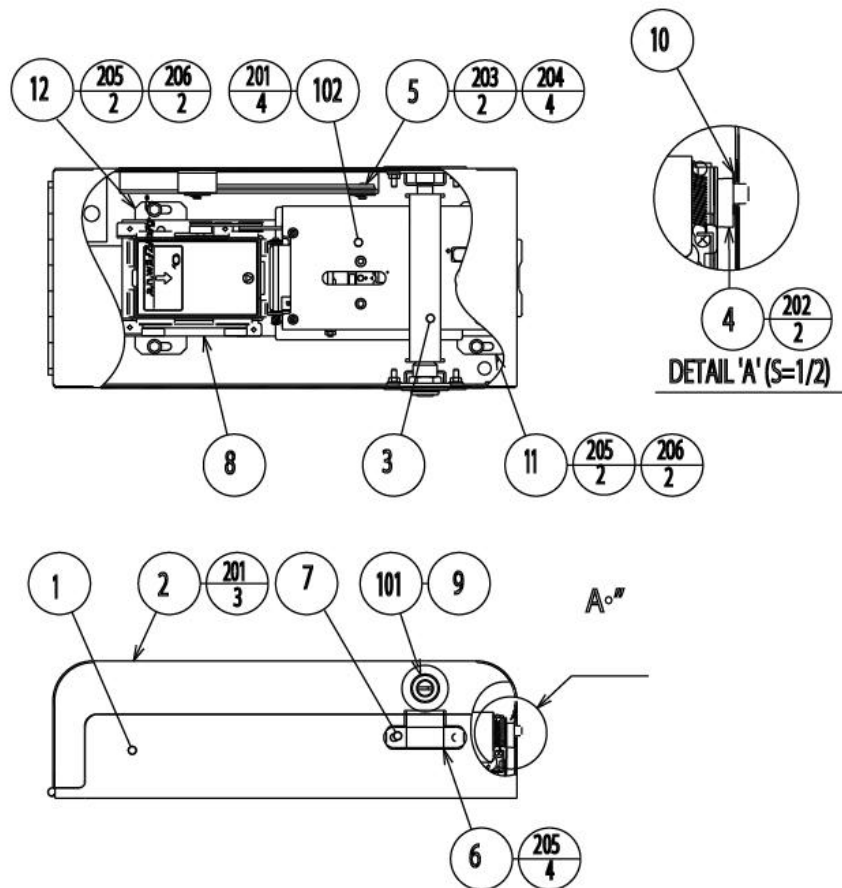

ITEM	PART NO.	QTY	DESCRIPTION	COMPONENT REF.
1	CKT-0401UK	1	CARD R/W BASE TWIN	
2	CKT-0402UK	1	CARD R/W COVER TWIN L	
3	CKT-0403UK	1	LOCKING TONGUE NARROW	
4	253-5512	1	CARD GUIDE	
5	CKT-0404UK	1	PLATE STAY	
6	CKT-0408UK	2	LOCK BRKT S	
7	CKT-1307	2	STUD PLATE	
8	VOF-0451UK	1	CARD R/W BRKT FOR VOF	
9	170048	1	SPACER-L+F REF 9203602	
10	CKT-0406UK	1	GATE	
11	CKT-0407UK	1	INSULATOR PLATE CKT	
12	VOF-0452UK	1	INSULATOR PLATE VOF	
13	100-5365-0606	1	OILES BEARING 80T 0606	(2)-1
101	220-5575UK	1	LOCK	(9)-1
102	601-11082	1	CARD R/W UNIT CRP-1231BR-10	
103	280-A01200-A	3	ROUTER TWIST D12 ADH	
201	000-P00308-W	7	M3X8 MSCR PAN W/FS PAS	(2)-3,(102)-4
202	000-F02508	2	M2.5 X 8 MSCR CSK BZP	(4)-2
203	065-E00500	2	DIA5 E RING	(5)-2
204	068-652016	4	M6 WSHR 20OD FLT PAS	(5)-4
205	050-F00400	8	M4 NUT FLG SER PAS	(6)-4,(11)-2,(12)-2
206	000-F00308	4	M3X8 MSCR CSK PAS	(11)-2,(12)-2
301	VOF-60050UK	1	WH CARD R/W	

### 8.27. VOF- 0460UK CARD UNIT TWIN R

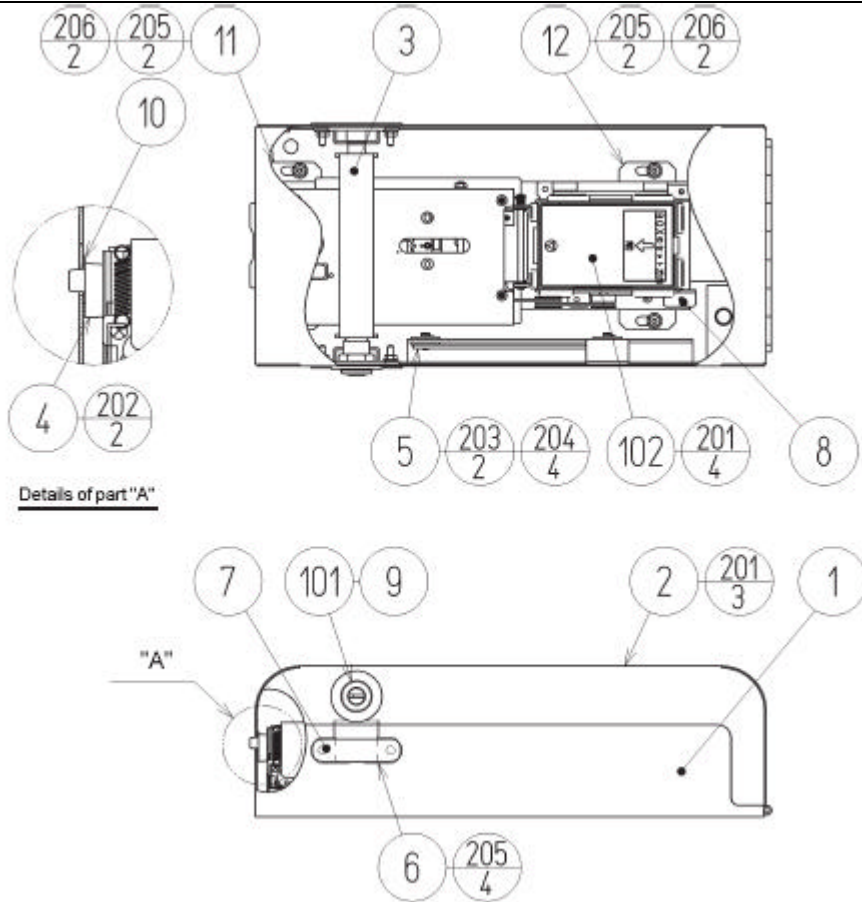

ITEM	PART NO.	QTY	DESCRIPTION	COMPONENT REF.
1	CKT-0401UK	1	CARD R/W BASE TWIN	
2	CKT-0422UK	1	CARD R/W COVER TWIN R	
3	CKT-0403UK	1	LOCKING TONGUE NARROW	
4	253-5512	1	CARD GUIDE	
5	CKT-0404UK	1	PLATE STAY	
6	CKT-0408UK	2	LOCK BRKT S	
7	CKT-1307	2	STUD PLATE	
8	VOF-0451UK	1	CARD R/W BRKT FOR VOF	
9	170048	1	SPACER-L+F REF 9203602	
10	CKT-0406UK	1	GATE	
11	CKT-0407UK	1	INSULATOR PLATE CKT	
12	VOF-0452UK	1	INSULATOR PLATE VOF	
13	100-5365-0606	1	OILES BEARING 80T 0606	(2)-1
101	220-5575UK	1	LOCK	(9)-1
102	601-11082	1	CARD R/W UNIT CRP-1231BR-10	
103	280-A01200-A	3	ROUTER TWIST D12 ADH	
201	000-P00308-W	7	M3X8 MSCR PAN W/FS PAS	(2)-3,(102)-4
202	000-F02508	2	M2.5 X 8 MSCR CSK BZP	(4)-2
203	065-E00500	2	DIA5 E RING	(5)-2
204	068-652016	4	M6 WSHR 20OD FLT PAS	(5)-4
205	050-F00400	8	M4 NUT FLG SER PAS	(6)-4,(11)-2,(12)-2
206	000-F00308	4	M3X8 MSCR CSK PAS	(11)-2,(12)-2
301	VOF-60050UK	1	WH CARD R/W	



## 9. APPENDIX A - ELECTRICAL SCHEMATIC

### 9.1. Wire Colours

THE WIRE COLOUR CODE IS AS FOLLOWS:

A	PINK
B	SKY BLUE
C	BROWN
D	PURPLE
E	LIGHT GREEN

Wires other than those of any of the colours listed above will be displayed by 2 alphanumeric characters:

1	RED
2	BLUE
3	YELLOW
4	GREEN
5	WHITE
7	ORANGE
8	BLACK
9	GREY

If the right hand side numeral of the code is 0, then the wire will be of a single colour shown by the left hand side numeral (see the list above).

Note 1: If the right hand side alphanumeric is not 0, that particular wire has a spiral colour code. The left hand side character shows the base colour and the right hand side one, the spiral colour.

[Example] 51----- WHITE/RED = WHITE wire with RED stripes

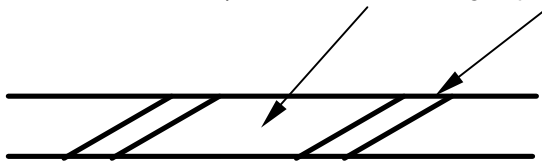

Note 2: The character following the wire colour code indicates the size of the wire.

K:	AWG18, UL1015
L:	AWG20, UL1007
None	AWG22, UL1007

### 9.2. Electrical Schematic

The following pages contain the electrical schematic for this machine.

Schematic 1 here

Schematic 2 here

Schematic 3 here